



# SEGMENTED ENERGY STORAGE MANAGEMENT

Mr.C. Arulkumar<sup>1</sup>, M. Jayabharathi<sup>2</sup>, S. Kowshika<sup>3</sup>, M. Manasha<sup>4</sup>, D. Dyana Mary<sup>5</sup>

1 Assistant professor 2,3,4,5 UG Students

Electrical and Electronics Engineering

Paavai Engineering College, Tamilnadu, India

## ABSTRACT

The segmented energy storage management (SES) is the current and typical solution of smoothing renewable power generation fluctuations. An SES based hybrid power systems require a suitable control strategy that can effectively utilize the maximum power output and battery state of charge (SOC). Proposed system presents the efficiency of a wind/photovoltaic (PV) hybrid power system simulation analysis undertaken to improve the smoothing performance of wind/ PV/BESS hybrid power generation and the effectiveness of battery SOC control. A smoothing control method for reducing wind/PV hybrid output power fluctuations and regulating battery SOC under the typical conditions is proposed. A real-time SES based power allocation method also is proposed.

**Keywords:** Hybrid power, segmented energy storage & state of charge

## 1. INTRODUCTION

The battery energy storage system can provide flexible energy management solutions that can improve the power quality of renewable-energy hybrid power generation systems. Several control strategies and configurations for hybrid energy storage systems, such as a battery energy storage system, superconducting magnetic energy system (SMES), a flywheel energy system (FES), an energy capacitor system (ECS), and a fuel cell/electrolyzer hybrid system have been proposed to smooth wind power fluctuation or enhance power quality. In the present study, under the assumptions that the capacities of the WP and PV hybrid generation system (WPPVGS) and BESS had already been determined and that we do not have ability to adjust the WPPVGS output power, a large-scale BESS was used to smooth the WPPVGS output power fluctuation.

### 1.1 OBJECTIVE

The objective of this project is to perform the maximum utilization of hybrid renewable energy to load.

The Fuzzy logic control system was implemented to simplify the operation of converter.

### 1.2 SCOPE

The Project proposes for alternative source of sensitive loads and also which helps to reduce the cost of non-renewable generation.

## 2. LITERATURE REVIEW

Chad Abbey et al experimented A Knowledge-Based Approach for Control of Two-Level Energy Storage for Wind Energy Systems [1]. A knowledge-based management algorithm is developed in order to

schedule the power from the two levels. The system is tested for two possible power systems applications and its performance is compared with that of an alternate scheduling approach. That results demonstrate the algorithm requires a lower storage rating due to its ability to better coordinate operation of the two devices.

S. M. Muyeenet all proposed a new method to enhance the transient stability of multi machine power system including wind farms. For this purpose, the energy capacitor system (ECS) composed of power electronic devices and electric double layer capacitor (EDLC) is proposed. The control scheme of ECS is based on a sinusoidal PWM voltage source converter (VSC) and fuzzy logic controlled dc–dc buck/boost converter using insulated gate bipolar transistors (IGBT). Two wind farms are considered to be connected to the power system. Two-mass drive train model of wind turbine generator system (WTGS) is used in the analyses as the drive train modeling has great influence on the dynamic characteristics of WTGS. Real wind speed data are used in the analyses to obtain realistic responses. Different types of symmetrical and unsymmetrical faults are considered as the network disturbance. The proposed ECS can enhance the transient stability of wind generators in multi machine power system as well as their low voltage ride through (LVRT) capability.

Hicham Fakhmet all proposed a Power Control Design of a Battery Charger in a Hybrid Active PV Generator for Load Following Applications. A PV -based hybrid active generator including lead-acid batteries and supercapacitors in a dc-coupled structure has been presented in order to deliver a prescribed power reference to the grid. The control system and the power management of the entire generator have been detailed. Special attention has been paid on the optimal battery charge. A specific algorithm for the charge operatingmode of lead-acid batteries has been proposed. The control design of charging the lead-acid batteries has beendeveloped and experimentally proven. Using the method proposed, the batteries can charge until a high battery SOC level is reached with overcharge security. Finally, the performances of this active generator for a load-following application show that excessive or insufficient power from PV panels are well balanced by the two embedded storage units.

Tatsuto Kinjoet all explained Output Leveling of Renewable Energy by Electric Double-Layer Capacitor Applied for Energy Storage System. The power generated from renewable energies is always fluctuating due to environmental status. Energy storage system is indispensable to compensate these fluctuating components. Energy capacitor system (ECaSS) connected an electric double layer capacitor (EDLC) with power-electronics devices is useful for the compensation of fluctuating power since one is capable of controlling both active and reactive power simultaneously. And also it proposes the current-source ECaSS (CS-ECS), which consists of EDLC, bi-directional DC-DC converter, and current-source inverter. The control system for the active/reactive was proposed in order to verify the effectiveness of the proposed system, CSECS and analysis system (power system interconnecting (WTG)are strictly modeled using computer simulation software with MATLAB/SIMULINK and *Sim Power Systems* based on instantaneous modeling.

S. M. Muyeenet all described Integration of an Energy Capacitor System with a Variable-Speed Wind Generator. A suitable and economical topology of ECS composed of a current-controlled voltage-source inverter, dc–dc buck/boost converter, and an electric double layer capacitor (EDLC) bank is presented, including their control strategies. Exponential moving average is used to generate the real input power reference of ECS. Another novel feature of this paper is the incorporation of a fuzzy-logic-controlled reference signal adjuster in the control of the dc–dc buck/boost converter, in which the stored energy of the EDLC bank is utilized in an efficient way. Due to this controller, the energy storage capacity of the EDLC bank can be reduced in size, thus resulting in reduction of the overall cost of the ECS unit as well as decrease in irrepressible operations during high and low energy levels of the EDLC bank.

### 3. CONVENTIONAL METHOD

A power management approach is proposed for the system components in the RAPS system, to operate the RAPS system during over and under generation scenarios. A power sharing strategy is formulated for battery energy storage and super capacitor based on the demand-generation variations of the RAPS system.

The key objective of the proposed control methodology is to operate the hybrid energy storage in such a manner that battery storage is used to mitigate low frequency fluctuation and the super capacitor is to mitigate high frequency fluctuation. An energy management strategy is proposed and implemented while harvesting maximum power from the wind. Reactive power management has been realized through integrating and operating a synchronous condenser in a coordinated manner with other energy resources of the RAPS system.

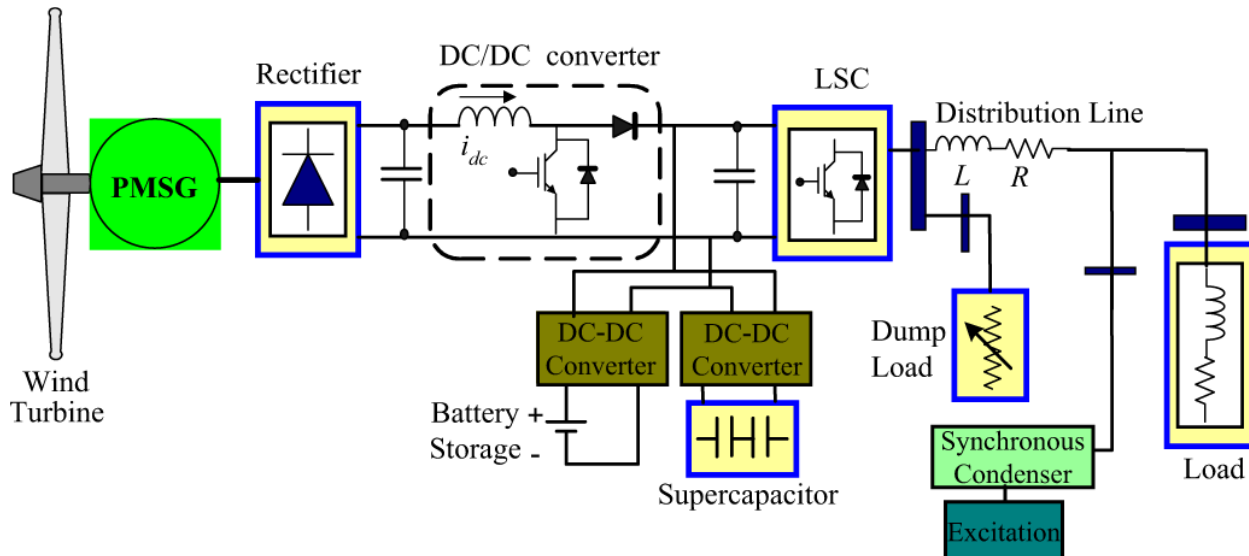

#### 4. PROPOSED METHODOLOGY

In order to overcome the above existing drawbacks,

The system implements a new methodology called Segmented Storage Energy System. The system provides the solution for power wasted by the turbine when the battery is in full charge condition.

The system has a two or more number of batteries which is integrated with the inverter hence the power can have distributed to the batteries one by one and it is stored.

(i.e., Instead of using dump load, we use an additional battery to store the excessive power)

Fuzzy logic control strategy is implemented.

To get a pure sine wave output we also introduce a modified sine wave topology.

## 4.1 Block diagram

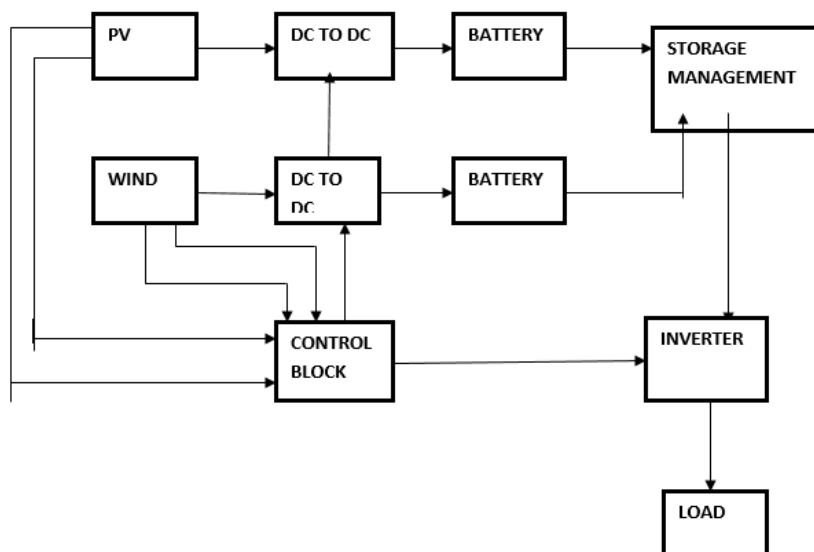

## 4.2 CIRCUIT DIAGRAM

### 4.2.1 RENEWABLE ENERGIES AND ENERGY STORAGE SYSTEMS

In a stable and reliable grid, the electricity supply must always match the electricity demand. Providing the exact amount of electricity to the customers is a technical challenging task. Typically, in a well-developed grid various types of base and peak load generation capacities are available and are managed according to the forecasted demand schedule. Usually generation is based on conventional fossil fuel or nuclear power plants, where the electricity output can be controlled accordingly. A growing level of grid penetration of intermittent renewable energy sources like wind and solar increases the need for additional control electricity. That could be conventional power plants, but generation costs would be relatively high due to a low number of full load hours and operation at levels of low efficiency.

Storage system can be an economical alternative for two reasons:

1) They can store excess electricity from intermitted energy sources and

2) Stored electricity can be dispatch on demand and storage system can therefore replace inflexible conventional power plants for controlling power range. In very basic terms, the storage systems store electricity when demand for electricity is lower than supply. Now these storage capacities can be managed just like conventional power generation capacity. Meaning, if forecasted demand for electricity is higher than the expected supply, the storage system can provide the required amount of electricity at a specific time. Thus storage systems are an important element for the deployment of intermittent renewable energy systems.

### 4.2.2 TYPES OF ENERGY STORAGE

Different types of storage can be applied in an electrical system. Chemical storage (e.g. batteries or hydrogen) and potential energy (e.g. pumped hydro or compressed air) are the most common type. Electrical storage (e.g. capacitors) and mechanical storage (e.g. fly-wheel) are used in more specific applications. Each type has its own underlying characteristics and thus suits to certain applications better than to others.

The most common characteristics to define a storage technology are: -

- Energy storage capacity [kWh or Ah]
- Charge and discharge rates [kW or A]
- Lifetime [cycles, years, kWh life]
- Round trip efficiency [%]
- Initial capital costs [USD/kW, USD/kWh cap, and USD/kWh life]
- Operating costs [USD/MWh, USD/kW x yr]
- Energy density [Wh/kg and Wh/m<sup>3</sup>] and power density [W/kg and Wh/m<sup>3</sup>].

These characteristics define the best technical and economical application for each technology.

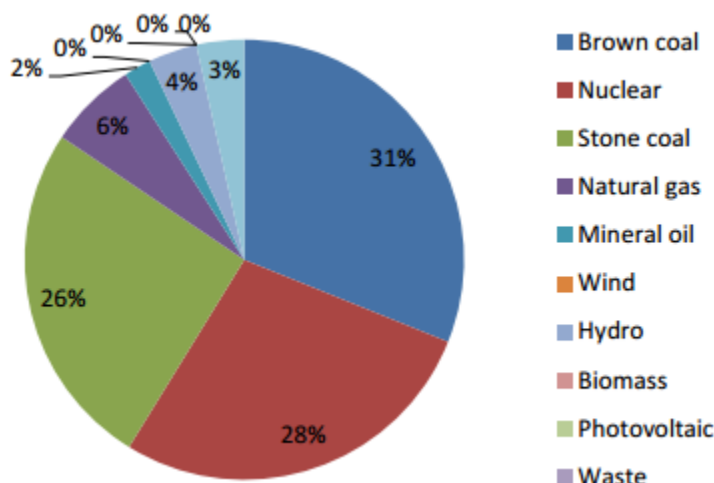

The different storage technologies based on the typical application size and useful discharge time. This gives a first indication on which type fits to what kind of application in terms of size and usage. However, local requirements must be taken into consideration. Reliability of the technology, costs, and required skill level for installation, operation and maintenance play a crucial role in the deployment of such technology in developing countries. Lead-acid batteries are the most common used and best understood technology. Invented in 1859 they are the oldest type of rechargeable battery. They are used mainly as starter batteries in automobiles and storage for backup power supplies, e.g. for mobile phone towers, factories, hospitals and stand-alone systems. Through their long history and worldwide distribution, they have the lowest cost and local knowledge for operation and maintenance can easily be build up. Therefore lead-acid batteries are currently the preferred type in renewable energy installations in developing countries.



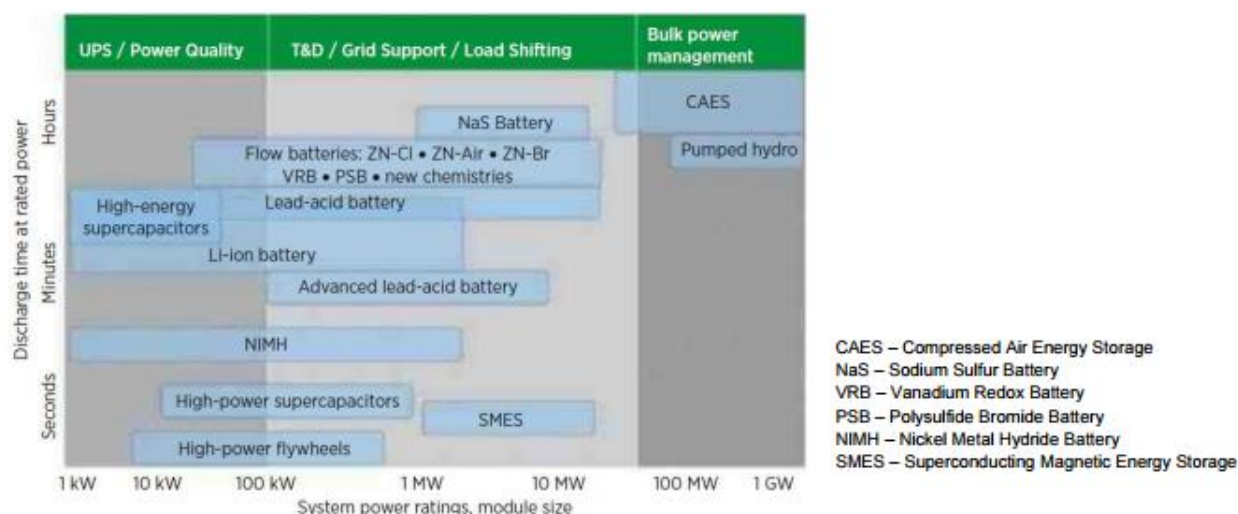

Summary of major storage technologies by discharge rate for different scales of application. Lithium-ion batteries are relatively new, but are already a mature technology in mobile applications. In comparison to lead-acid batteries, lithium-ion batteries have a better performance characteristic and can handle deeper discharges, thus they can use almost their entire stated capacity with little impact on the lifetime. This characteristic and the lower requirements on operation and maintenance compensates for the higher upfront cost. However, in grid application they still need further development. Lead-acid and lithium-ion batteries are currently the most suitable technologies for renewable energy applications in the range from 10kW to 10MW in developing countries. Other technologies have at present disadvantages in discharge time, application size, costs, and operation and maintenance requirements. Therefore, this report will focus on lead-acid and lithium-ion battery technologies only.

#### 4.2.3 TECHNOLOGY FOCUS

A conventional grid fundamentally consists of generation units, transformers, transmission lines, measurement and control system, and the load (consumers). The grid quality and stability is managed by adjusting the conventional generation capacities (nuclear, coal, oil, gas, hydro) according to the demand from the consumers. With an increasing share of intermittent renewable energies, the grid can still be managed by adjusting conventional capacities up to a certain efficiency level. Beyond that point, the output from renewable sources must be limited or storage systems must store the temporary excess energy. Thus, the introduction of intermittent renewable energies beyond a certain level into a conventional grid increases the requirements on storage, measurement and control systems. Therefore, the main technological challenges in such a system are in the area of:

#### 4.2.4 STORAGE AND STORAGE MANAGEMENT SYSTEMS

The development and manufacturing of energy storage system requires high R&D investments and long-term know-how building. The exact design and combination of different materials and components is the key to create reliable and commercial viable products. Moreover, the management of the energy flow in and out of the storage device is critical to maintain the long-term performance quality at the specified parameters of the storage device.

#### 4.2.5 GRID AND ENERGY MANAGEMENT SYSTEMS

The interaction of various types of electricity generation systems, storage systems and consumers also increases the requirements on grid and energy management systems. Conventional systems do not possess the measurement devices, control functions and algorithms to deal with the increasing amount of information. It requires the development and adaptation of sophisticated hard- and software solutions to monitor and control all generation and consumption units in the grid. System solutions design, installation

and operation. Considerable know-how and experience is necessary for the design, construction and operation of renewable energy and storage systems. On-site analysis and specialized simulation software are necessary to find the precise system specifications and the right components. Especially for island hybrid systems, right sizing of all components to the expected demand is very important for the required technical and economic performance. Moreover, training of local technicians and service offerings from the installer ensure a long-term reliable operation of a system.

### 4.3 BATTERY MANAGEMENT

Due to the fast depletion of fossil fuel and increasing pollution rate, renewable energy sources have become the most effective source of energy. But the major challenge in integration of these renewable sources is its intermittent nature and cost. PV is one of the most effective renewable energy sources, but it is not available at night time. This ensures the requirement of two or more renewable energy sources (Torreglosa et al., 2014). Therefore, to make this kind of hybrid system more reliable and cost effective, there must be some energy storage devices to store the available energy when available and also feed the load under low PV output situations. Battery and Super Capacitor (SC) are used for storage purposes. The important advantage of battery over SC is its high energy density. They can store at least 3–30 times more charge than SC (Thounthong et al., 2009). Whereas, SCs are able to deliver hundred to thousand times more power than a similar sized Battery (Weddell et al., 2011). So Battery is able to supply long term energy demand compared to SC.

Under all operating conditions, there is a point on the P–V curve at which the entire PV system operates. This allows the operation to take place producing maximum output power with maximum efficiency. Many MPPT methods have been developed and implemented. The methods vary in complexity, sensors required, convergence speed, cost, implementation hardware, range of effectiveness, popularity, and in other respects (Faranda et al., 2008, Rohrig and Lange, 2008, Faranda and Leva, 2008, Salas et al., 2006, ESRAM and Chapman, 2007, Zegaoui et al., 2011). To incorporate MPPT tracking, an intermediate DC–DC boost converter is proposed which is controlled by Perturb & Observe (P&O) method. The MPPT tracking is applied to a standalone PV system in order to extract maximum available power at all values of solar irradiation and temperature. The P&O technique (Femia et al., 2005, Femia et al., 2007), which is based on iterative algorithms, is widely used since it is easy to implement with rapid tracking capabilities and minimum steady state oscillations.

Many researchers have focused their study on control of hybrid system. Garca et al. (2013) have studied FC- battery- SC based hybrid system to supply hybrid vehicles type load. Glavin et al. (2008) have studied control of PV - SC- Battery based hybrid energy system. Guiting et al. (2013) have implemented flatness based control strategy and classical PI controller based control to study PV- FC- SC energy system respectively. Thounthong et al. (2013) have taken PVFC Battery-SC based hybrid system for their study.

In this paper, a fuzzy logic controller (FLC) for maintaining a constant DC link voltage for standalone PV applications is proposed. PV is used as the primary energy source but due to the fluctuating nature of the PV power supply, a battery is connected in parallel as a back-up energy storage system. Perturb and Observe control algorithm based MPPT controller gives the required duty cycle to achieve MPP. Bidirectional dc–dc buck-boost converter is used for controlling the power flow from the battery. A FLC controller was designed to regulate the duty ratio of the MOSFET switches to maintain power balance in the standalone system under varying solar irradiation conditions. The proposed hybrid system can be implemented in rural households for lightning purpose and running isolated pumps for effective harvesting.

## 5. SOLAR POWER TRACKING

### 5.1 Maximum power point tracking (MPPT)

MPPT is a technique that charge controllers use for wind turbines and PV solar systems to maximize power output. PV solar systems exist in several different configurations. The most basic version

sends power from collector panels directly to the DC-AC inverter and from there directly to the electrical grid. A second version, called a hybrid inverter, might split the power at the inverter, where a percentage of the power goes to the grid and the remainder goes to a battery bank. The third version is not connected at all to the grid but employs a dedicated PV inverter that features the MPPT. In this configuration, power flows directly to a battery bank. A variation on these configurations is that instead of only one single inverter, micro inverters are deployed, one for each PV panel. This allegedly increases PV solar efficiency by up to 20%. New MPPT equipped specialty inverters now exist that serve three functions: grid-connecting wind power as well as PV solar power, and branching off power for battery charging.

This article about the application of MPPT concerns itself only with PV solar. Solar cells have a complex relationship between temperature and total resistance that produces a non-linear output efficiency which can be analyzed based on the I-V curve. It is the purpose of the MPPT system to sample the output of the PV cells and apply the proper resistance (load) to obtain maximum power for any given environmental conditions. MPPT devices are typically integrated into an electric power converter system that provides voltage or current conversion, filtering, and regulation for driving various loads, including power grids, batteries, or motors. Solar inverters convert the DC power to AC power and may incorporate MPPT: such inverters sample the output power (I-V curve) from the solar modules and apply the proper resistance (load) so as to obtain maximum power. MPP (Maximum power point) is the product of the MPP voltage ( $V_{mpp}$ ) and MPP current ( $I_{mpp}$ ).

## 5.2 I-V CURVE

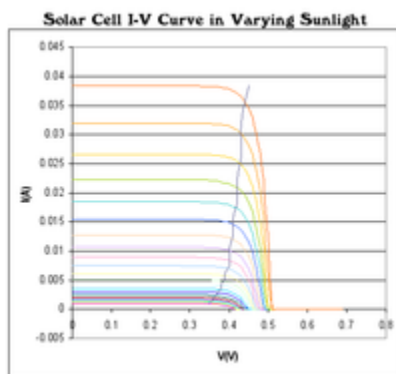

Photovoltaic solar cell I-V curves where a line intersects the knee of the curves where the maximum power transfer point is located.

Photovoltaic cells have a complex relationship between their operating environment and the maximum power they can produce. The fill factor, abbreviated  $FF$ , is a parameter which characterizes the non-linear electrical behavior of the solar cell. Fill factor is defined as the ratio of the maximum power from the solar cell to the product of Open Circuit Voltage  $V_{oc}$  and Short-Circuit Current  $I_{sc}$ . In tabulated data it is often used to estimate the maximum power that a cell can provide with an optimal load under given conditions,  $P = FF * V_{oc} * I_{sc}$ . For most purposes,  $FF$ ,  $V_{oc}$ , and  $I_{sc}$  are enough information to give a useful approximate model of the electrical behavior of a photovoltaic cell under typical conditions.

For any given set of operational conditions, cells have a single operating point where the values of the current ( $I$ ) and Voltage ( $V$ ) of the cell result in a maximum power output. These values correspond to a particular load resistance, which is equal to  $V / I$  as specified by Ohm's. The power  $P$  is given by  $P = V * I$ . A photovoltaic cell, for the majority of its useful curve, acts as a constant current source.<sup>[2]</sup> However, at a photovoltaic cell's MPP region, its curve has an approximately inverse exponential relationship between current and voltage. From basic circuit theory, the power delivered from or to a device is optimized where the derivative (graphically, the slope)  $dI/dV$  of the I-V curve is equal and opposite the  $I/V$  ratio (where  $dP/dV=0$ ). This is known as the **maximum power point** (MPP) and corresponds to the "knee" of the curve.



A load with resistance  $R=V/I$  equal to the reciprocal of this value draws the maximum power from the device. This is sometimes called the 'characteristic resistance' of the cell. This is a dynamic quantity which changes depending on the level of illumination, as well as other factors such as temperature and the age of the cell. If the resistance is lower or higher than this value, the power drawn will be less than the maximum available, and thus the cell will not be used as efficiently as it could be. Maximum power point trackers utilize different types of control circuit or logic to search for this point and thus to allow the converter circuit to extract the maximum power available from a cell.

## 6. CONCLUSION

The PV and wind power generation is their unstable power output, which can impact negatively on utility and micro grid operations. Simulation results demonstrate that the proposed control strategy can manage SES power and SOC within a specified target region while smoothing PVGS and WPGS outputs. Another significant issue is the means by which an appropriate battery capacity for this application is to be determined.

The power control strategies for large scale renewable hybrid power systems taking into account the optimum capacity of SES and battery aging will be discussed in the near future combined with smoothing control application of wind and PV power generations. Simulation is done with the help of MATLAB using SES to improve the SOC in PV/Wind energy system.

## 7. REFERENCES

1. M.Swierczynski & R. Teodoresu & C.N. Rasmussen & P. Rodriguez & H. vikelgard Hierarchical control of vehicular fuel cell/battery hybrid powertrain. -2010
2. Liangfei Xu&Minggao Ouyang & Jianqiu Li & Jianfeng Hua Hierarchical control of vehicular fuel cell/battery hybrid power train.
3. Xiangjun Li, Senior Member IEEE, Dong Hui and Xiaokan Lai Battery Energy Storage Station (BESS)-Based Smoothing Control of Photovoltaic(PV) and Wind Power Generation Fluctuations-2010
4. Yuanxiong Guo, Student Member, IEEE, Miao Pan Optimal Power Management of Residential Customers in the Smart Grid-2012