



INTERNATIONAL JOURNAL OF CREATIVE RESEARCH THOUGHTS (IJCRT)

An International Open Access, Peer-reviewed, Refereed Journal

Cross-Verification of Fuel Consumption in Backup Generator of Telecom Services

Sushovan Podder¹, Kago Ampi², Mudasir Farooq³, Priyanka Kumari⁴, Kapil⁵, Dr. Amit Kumar Singh⁶

^{123456*}School of Electronics and Electrical Engineering
Lovely Professional University, Punjab

Abstract- Throughout India, there has been a rapid growth in the telecom towers and the unpredictable electric grid supply in India has become a great challenge to this. Telecom towers usually has diesel generator, batteries and various power management equipments, these generators runs on fossil fuels. Estimated, the telecom tower industry consumes over 2.5 billion litres of diesel annually. This also leads to theft in large amount from the sites and has negative impact on network availability and operational expenditure. This paper accentuates the issue of telecom sector and discusses the system that has been designed and tested, which will offer a solution to reduce the operational cost and increase the availability.

Keywords- Fuel Theft, Fuel monitoring, Fuel level management

I. INTRODUCTION

India ranks second among the largest telecommunication market. The total subscriber base in the country stands at 1,168 million with a tele-density of 86.22% as of September 30,202[8]. In this fast growing market, over 440,000 telecom towers has been reported, which needs affordable and reliable electricity for smooth operation. The grid currently powers only 33% of telecom towers. This lack of access to reliable and sufficient electricity has posed as a great challenge to this sector.

To cope with this problem, most towers has installed generator at the site. Over 60% of the telecom towers are powered by diesel. In rural India, diesel powers 87% of telecom towers due to lack of grid power. In urban areas, the figure is 33%. Every year these telecommunication sectors spend largely on the purchase of the fuel. In most of the generator the fuel is filled manually and this raises the issue of fuel theft and mismanagement of required fuel level.

To overcome this problem, a system has been designed and discussed in this paper called as Cross Verification of fuel consumption in the backup generator of the telecom services.

This system records the log, provides information about the fuel status and monitor the fuelling for any anomaly. The prototype of the system has been developed and aims to significantly reduce the fuel theft, operating expenditure and increase network availability.

This research paper has six sections. Section 2 is the researches and related works by different researchers. Section 3 discuss about the fuel theft issue. Section 4 of the paper explains the prototype design and development of the system. Section 5 is the result of the system. Section 6 is the conclusion.

II. RESEARCH AND RELATED WORKS

The researches have done great work to manage the problems of fuel theft, done at various places like cell sites, telecommunication tower, vehicles, station etc. In this regard Kunal Dhandel et al., have done a survey on fuel level measurement techniques used at various places, but has no idea of implementation [4]. Gbenga et al., have developed a mechanical sensor which accurately measure the fuel level and reports it back to mobile phones of the operator [7].

There is another research going on fuel theft issue in another place rather than cellular sites, by Riny Sulityowki et al., on remote monitoring of fuel tank by use of android application[5], where Bluetooth and GSM technology has been used to report any fuel theft or any leaks from the tank. Alwyn Hoffman et al., have identified different issue relating to fuel used in logistics [10]. Most of these systems do not cope with all kind of fuel theft, and also in these designs other features cannot be scaled, which can be incorporated in the proposed system in future

A significant amount of work has also been done on cellular sites and its patents are filed. Bejiman Stump has

developed a system to monitor the cellular sites power and discharge of the battery [3]. They inspect different sites

parameters to check the feasible conditions for battery discharge or they run power generator [3].

III. FUEL THEFT ISSUE

In case of supply from national grid goes off, the telecom sites' highly depends on the generators which works on the fuel i.e diesel, therefore each site contains a fuel tank attached to a generator. The cellular operators invest heavily on fueling of sites. Most of the time they are filled in advance to avoid any scenario where the fuel gets exhausted and the filling team reach the site after it goes offline. There have also been several reports on fuel theft from the sites. The estimated theft cost is a big figure, which is also a great financial loss of the operators.

This fuel theft is done mainly by two parties: the site guard and the filler who fill less fuel in the tank. Various measures have been taken by the operators as like increasing the security and penalties but to no vial, there is still the same issue [1]. Both the parties deny the fuel theft and put allegations on each other for the theft. There should be a system to identify the culprit for the theft; with this information this theft matter can be remarkably reduced. This issue needs to be addressed as it impacts financially high for the operator's operational expenditure.

IV. CROSS VERIFICATION OF FUEL CONSUMPTION IN BACKUP GENERATOR OF TELECOM SERVICE

The fuel theft has high impact on its availability and also over sensitive electronic equipments which gets damaged due to power failures and per site fuel cost.

To address this issue, a system has been designed. This is an IOT based (internet of things) to measures the fuel level and remaining quantity in the tank and send it through the server, this system will also report any anomaly (fuel theft) occurred during filling of the fuel tank or by some other person.

The system has a microcontroller which works by periodically checking fuel level of the tank using fuel sensor dipped into the tank. The fuel sensor reports back the fuel level, which further reports this information to cellular communication module, which is logged in a database on cloud server. This information can be viewed by the site engineer or the operator at the telecom site. The prototype which is built for the proposed system is being made with Atmega 328 microcontroller along with VL53L0X sensor as fuel sensor and ESP01 wifi board.

A. Data Flow Chart

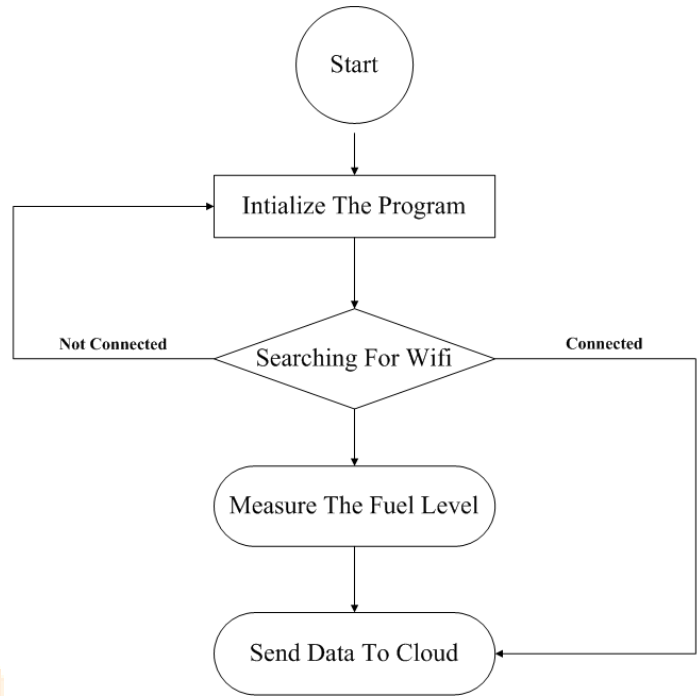

Fig 1. Data flow chart for fuel monitoring

The system starts and initializes the program which searches for Wi-Fi. If it is not connected, it initializes the programs repeatedly until it gets connected. When the wifi gets connected then it sends data to the cloud, then it measures the fuel and send the information to the cloud server as shown in Fig 1.

B. Working of the system

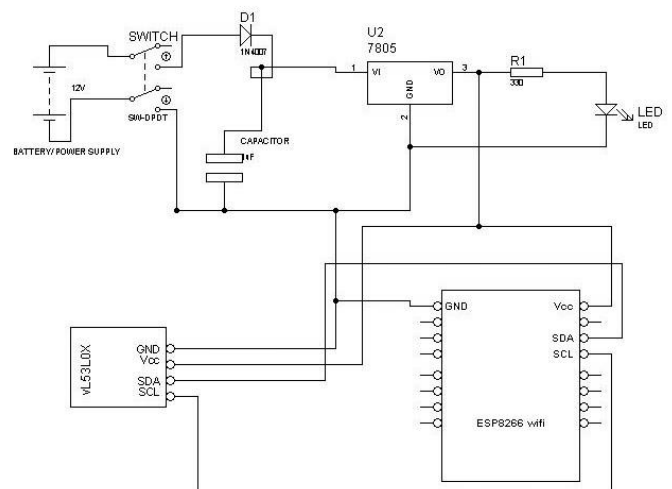

Fig 2. Circuit Diagram

In this system, the module is connected to diesel generator's battery or AMF panel from the telecom site. When the system gets the power supply then the program runs, which will receive the data through the cloud server, when the VL53L0X sensor sends the information after the sensing the fuel level. The received data is then manipulated as per requirement. These data and information can be received anywhere using internet.

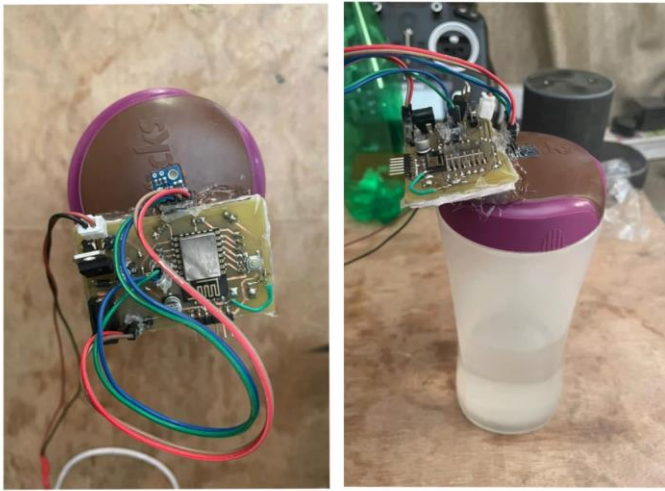

Fig 3. Prototype of fuel monitoring system

We have used VL53L0X sensor to measure the distance between the top surface of tank to fuel surface. This then sends the to ESP8266 wifi module through SDA and SCL pin as shown in Fig 2. Then the data is send to the BLYNK's server through BLYNK token mentioned in the program, when connected to the internet. These data is then taken from the server and displayed on the particular BLYNK account, these received data is then represented in the form of graphs, which shows the level of fuel inside the tank.

C. Software Program

```
// Libraries
#define BLYNK_PRINT Serial // to print serially for BLYNK
#include <ESP8266WiFi.h> // wifi esp8266 library
#include <BlynkSimpleEsp8266.h> // Blynk library for esp8266 wifi
#include <SoftwareSerial.h> // Software serial
#include <Adafruit_VL53L0X.h> // vl53L0x library
Adafruit_VL53L0X lox = Adafruit_VL53L0X(); // define lox as value type for sensor

int soil=A0, state=0, state1=0, val, fuel, rmn, km;
BlynkTimer timer;
WidgetLED ledx(V7);

char auth[] = "hxNhT934Hbd9bj0Fkf0DCgeMUKnd_VZ4";//blynk token that is
used to connect data to Blynk IoT Server
char ssid[] = "Oye Mote";// wifi hotspot name
char pass[] = "abcd@54321";// wifi Hotspot password

void sendSensor() // function to send sensor data
{
    VL53L0X_RangingMeasurementData_t measure; // assign variable 'measure to
    decode the parameter of sensor'

    lox.rangingTest(&measure, false); // assign measure as false to get data

    if (measure.RangeStatus != 4) { // phase failures have incorrect data

        raw=(((measure.RangeMilliMeter)/10)-4); // store the sensor data to 'raw'
        variable
```

```
    if (raw>=17) // if raw data is greater than tank height
    {
        raw=17;
    }
    fuel=17-raw; // Fuel level

    Serial.println(fuel); // serially print the fuel level
    km=fuel*12; // Serially print the km
    Serial.println(km);

} else { // if sensor not found, print out of range
    Serial.println(" out of range ");
}
Blynk.virtualWrite(V4, fuel); // update the fuel level to BLYNK server at
V4 virtual pins
Blynk.virtualWrite(V5, km); // update the approx travel in remaining
fuel to BLYNK server at V5 virtual pins
delay(100); // time delay for 100ms
}

void setup()
{
    Serial.begin(9600); // Serial start at 9600 baud rate
    while (! Serial) { // if serial not available
        delay(1);
    }

    if (!lox.begin()) { // if sensor not found,
        Serial.println(F("Failed to boot VL53L0X")); // then display failed
        while(1);
    }

    delay(2000); // time delay for 2000ms

    Serial.println("Wifi based Fuel Monitoring"); // serially print
    Blynk.begin(auth, ssid, pass); // Authenticate the Blynk server token to blynk
    server using wifi name and password parameter .
    delay(5000); // time delay for 5000ms
    timer.setInterval(1000L, sendSensor); // timer to sensor data from sensor to
    Blynk IoT App
}

void loop()
{
    Blynk.run(); // Call function
    timer.run(); // Timer
}
```

D. BLYNK

This platform lets your hardware projects be controlled and monitored from your iOS or Android device build as shown in Fig 4 .You can create a project dashboard and graphs onto the screen. Blynk can support most Raspberry Pi models, Arduino boards, the ESP8266 and other common microcontrollers and single-board computers [9].

you can also create a local Blynk server, which allows you to keep everything within your own home network., which is useful if you're setting up a network in a remote location.

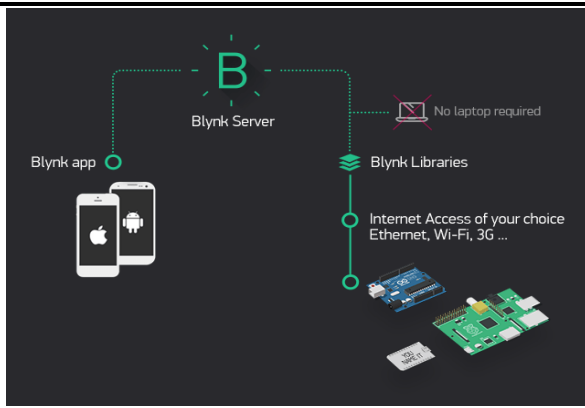

Fig 4. BLYNK

E. Hardware Development

The list of hardware used in the development of the system.

Component used	Specification	Quantity
Power Supply +12V DC	Power Supply	1
Step Down Power Supply +12V to +5V DC	Power Supply Adaptor	1
ESP01 Wi-Fi	Wi-Fi Modem	1
Connecting wire male to male	To connect	1 pack
Connecting wires male to female	To connect	1 pack
Connecting wires female to female	To connect	1 pack
Push Button	Reset	1
vL53L0X Sensor	Measurement sensor	1

i. Interfacing Cable

USB 2.0 printer cable is used as interfacing cable which is ideal for connecting Arduino Boards, Power bank, scanner, hard drive, printer, server, camera and more, to a laptop, computer and any other USB-enabled device.

ii. Power supply adapter +12v:

The power supply used is Adapter +12V, 1A Power supply; it is suitable for arduino boards, Atmega boards & ARM Processor Board.

iii. +Step Down Power supply +12V to +5V:

It is a DC to DC voltage converter +12V DC to +5V DC. For suitable sequential power output is Stepped down the +12V/+9V Dc Input Power to +5V DC.

iv. Push Button:

The push button is digital switch, to perform a variety of tasks. Push button is used to trigger to restart the system.

v. VL53L0X Sensor:

This sensor is a new generation Time-of-Flight (ToF) laser-ranging module which can measure distances up to 2m away, this allows it to give accurate results independent of the targets distance, surface and colour Fig 5.

This sensor combines leading-edge SPAD array (Single Photon Avalanche Diodes) and embeds ST's second generation Flight Sense™ patented technology. The sensor consists a 940 nm VCSEL emitter (Vertical Cavity Surface-Emitting Laser), which is absolutely invisible to the human eye and is coupled with internal physical infrared filters, which enables longer range distance, high immunity to ambient light, and better robustness to mask the glass optical crosstalk.



Fig 5.VL53L0X sensor

vi. ESP01 Wi-Fi Board-

The ESP01 Wi-Fi is also known as ESP8266 serial Wireless Transceiver Module is a self-contained SOC that allows any microcontroller access to your Wi-Fi network. Either hosting an application or offload all Wi-Fi networking functions from another application processor can be done by the module. The ESP8266 serial module is a cost-effective board with a large and ever growing community Fig 6.

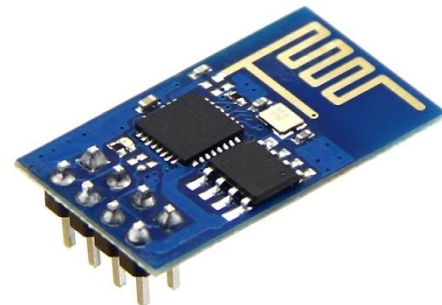

Fig 6. ESP 8266 ESP01 Wi-Fi board

vii. Connecting wires:

Connecting wires provides an electrical current a path to travel from one point on a circuit to another. Most of the connecting wires are made up of copper or aluminum, as copper is cheap and electrically conductive.

V. RESULT

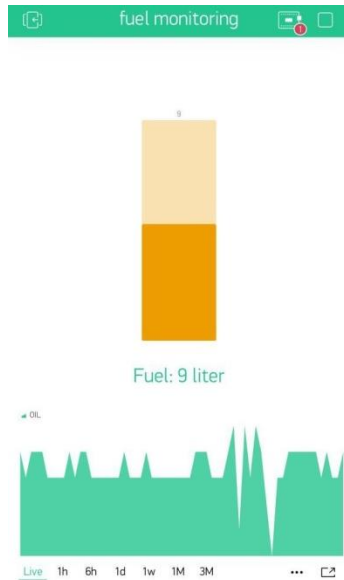

Fig 7. Result

In the prototype, the sensor has been calibrated according to the vessel used; the highest and the bottom level of the vessel is divided by 17 to make the scale Fig 3. When water or fuel is filled in the vessel, the result displayed fuel of 9 liters in the blynk app. The result will vary with the change in the fuel level.

VI. CONCLUSION

This system which is IOT based, has been developed to cope with the fuel theft in the telecom sites. The sensors senses the fuel level and sends to the cloud server which will provide those information to the site engineer or the technician, which will help to maintain the fuel level in the generator and reduce the operational expenditure too. Maintaining the level will increase the life of the generator and the telecom towers. With this system, we hope to curb the main issue of fuel theft and monitor the fuel level.

ACKNOWLEDGMENT

We are sincerely thankful to Lovely Professional University, Punjab for providing us with the opportunity to write a research paper in the form of a dissertation on the topic “**Cross Verification of fuel consumption in backup generator of telecom services**”.

We are highly indebted to **Dr. Amit Kumar Singh**, professor of Deptt. of ECE, for guiding us in every stage of this research paper, not only during the course of the project, but throughout our Bachelor’s Degree. Without his support it would have been difficult for us to prepare the paper so meaningful and interesting. We with all our hearts would like to thank our colleagues for the assistance and support provided by them.

Our Team

REFERENCES

- [1] Mohammad Asif Khan, Ahmad Waqas, Qamar Uddin Khand, Sajid Khan, Context Aware Fuel Monitoring System for Cellular Sites, Vol. 8, No. 8, 2017
- [2] Nandini Hiremath, et al., “Smart Fuel Theft Detection using Microcontroller ARM7”, International Journal of Engineering Research & Technology. Volume. 4 - Issue. 09, September – 2015
- [3] Benjamin Stump, “Hybrid power management system and method for unmanned remote cell sites”, Westell Inch, Patent issued Aug, 2014
- [4] Kunal Dhanel, Sarang R. “Fuel Level Measurement Techniques: A Systematic Survey”, International Journal of Research in Advent Technology, Vol.2, No.4, April 2014 E-ISSN: 2321-9637.
- [5] Riny Sulityowati , Bayu Bhatra Kurnia Rafik, “Prototype Design of a Realtime Monitoring System of a Fuel Tank at a Gas Station Using an Android-Based Mobile Application”, Proceedings of Second International Conference on Electrical Systems, Technology and Information, 2015
- [6] Wissam Balshe, “Power system considerations for cell tower applications”, Technical information from Cummins Power Generation, Power topic #9019, 2011
- [7] Gbenga Daniel Obikoya, “Design, Construction, and Implementation of a Remote Fuel-level Monitoring System”, EURASIP Journal on Wireless Communications and Networking,,December 2014.
- [8] IBEF, Indian Brand Equity Foundation, Media Reports and Press Releases, Cellular Operators Authority of India (COAI), Telecom Regulatory Authority of India (TRAI), Department of Telecommunication (DoT), Department for Promotion of Industry and Internal Trade (DPIIT), India Services Sector Report by Deloitte
- [9] BLYNK, <https://docs.blynk.cc/#links>
- [10] Alwyn J. Hoffman et al. , “An Investigation into the Economics of Fuel Management in the Freight Logistics Industry”, 17th International Conference on Intelligent Transportation Systems (ITSC)., October, 2014, China