



## BATTERY MANAGEMENT SYSTEM IN ELECTRICAL VEHICLE USING LITHIUM - ION AND LEAD - ACID

SHIVAM MISHRA , VIVEK KUSHWAHA , RASHPAL

[1] SHIVAM MISHRA  
ELECTRICAL ENGINEERING  
LOVELY PROFESSIONAL UNIVERSITY

[2] VIVEK KUSHWAHA  
ELECTRICAL ENGINEERING  
LOVELY PROFESSIONAL UNIVERSITY

[3] RASHPAL  
ELECTRICAL ENGINEERING  
LOVELY PROFESSIONAL UNIVERSITY

[4] DR.AMIT KUMAR SINGH (CO-AUTHOR)  
DEPARTMENT OF ELECTRICAL AND ELECTRONICS  
ENGINEERING  
LOVELY PROFESSIONAL UNIVERSITY JALANDHAR  
PUNJAB

### ABSTRACT

A battery management system (BMS) is an electronic regulator that monitors and controls the charging and discharging of rechargeable batteries. It is simply battery monitoring, keeping a check on the key operational parameters during charging and discharging such as voltages, currents and the battery internal and ambient temperature. The monitoring circuits would normally provide inputs to protection devices which would generate alarms or disconnect the battery from the load or charger should any of the parameters become out of limits.

**Keywords:** BATTERY CELL MONITORING , VOLTAGE CONTROL , TEMPERATURE CONTROL

### INTRODUCTION:

Electrification in the vehicle is the most viable way to achieve clean and efficient transportation that is crucial to the sustainable development of the whole world. In the near future, electric vehicles (EVs) including hybrid electric vehicles (HEVs), will be the best clean energy source for the world. There we use different kind of batteries. We use in the electrical vehicle as per that efficiency .

Electric vehicles (EVs) are powered by a large number of battery cells, requiring an effective battery management system (BMS) to maintain the battery cells in an operational condition while providing the necessary power efficiently.

Battery management systems (BMS) make decisions on charge/discharge rates on the basis of load demands,

### PROPOSED METHODOLOGY:

Energy and environmental issues have long been challenges facing the world's automotive industry. For facing these problems,

In the early 1990s, it had lots of advantages over their competitors when the many Motor Vehicle Company starts building their own electric car.

Professor **William Edward** and **John Perry** were distinguished the First electric car in England. **Why Need BMS (Battery Management System) in Electric vehicle**

In the electrical vehicle A BMS may protect its battery by preventing it from operating outside its safe operating area, such as:[citation needed]

Over-current (may be different in charging and discharging modes)

Over-voltage (during charging), especially important for lead-acid and Li-ion cells Under-voltage (during discharging)

Over-temperature.

Under-temperature.

Over-pressure .

Ground fault or leakage current detection (system monitoring that the high voltage battery is electrically disconnected from any conductive object touchable to use like vehicle body)

The BMS may prevent operation outside the battery's safe operating area by:

Including an internal switch (such as a relay or solid state device) which is opened if the battery is operated outside its safe operating area.

Requesting the devices to which the battery is connected to reduce or even terminate using the battery.

Actively controlling the environment, such as through heaters, fans, air conditioning or liquid cooling

*State-of-Charge Determination:*

One feature of the BMS is to keep track of the state of charge (SOC) of the battery.

The nominal capacity is given by the manufacturer and represents the maximum amount of charge that can be stored in the battery. In general, the SOC of a battery is defined as the ratio of its current capacity () to the nominal capacity ()

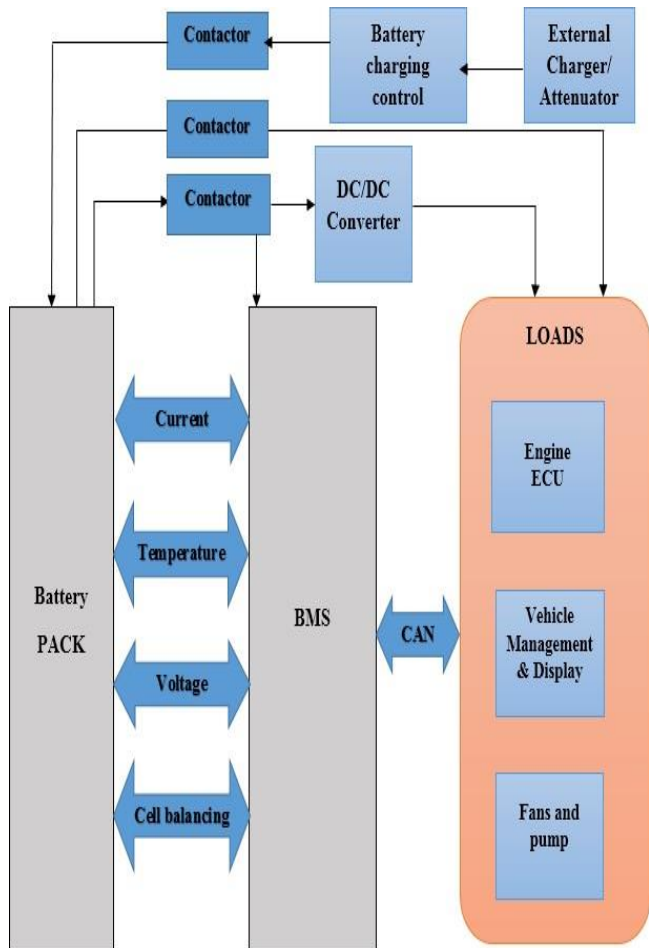

Fig: Basic block diagram of BMS In the vehicle there are basically used CAN controller for the operation of different parts. But in my project I am not using CAN bus.

## Description:

External charger is connected to the battery by contactor and it is control by battery control unit. Loads like ECU engine and controller are connected to the battery by DC/DC converter to give sufficient supply required to that by using contactor. BMS control the current, temperature and voltage in each cell in the battery. Cell: A cell consists of two electrodes in a container filled with an electrolyte

## Battery:

Two or more cells connected in an appropriate series/parallel arrangement to obtain the required operating voltage and capacity for a certain load. The terms of battery we use lithium ion and lead acid battery, except where a distinction between cells and batteries is needed. A good example is a battery pack, which consists of several cells connected in series and/or parallel.

**Loads on vehicle battery:** resistance load.

## Displays Cell balancing ;

:Cell balancing is a method of compensating weaker cells by equalizing the charge on all cells in the chain to extend the overall battery life.

In chains of multi-cell we have used three lithium -ion battery and Connection of battery pack to the battery monitoring.

The battery pack is 12 volts and 2.6AHh. It consists of three lithium-ion cells connected in series. Each cell is connected to the load resistance through Mosfet. Passive cell balancing means equalizing the state of charge of each cell by wasting or dissipating energy through a resistor. In passive cell balancing, each cell state of charge value will be brought to the one cell value which has a low state of charge.

The state of charge of each cell is different and when the passive cell balancing will be applied, the state of charge of each cell will come to 15% because cell 1 has a low state of charge compared to others.

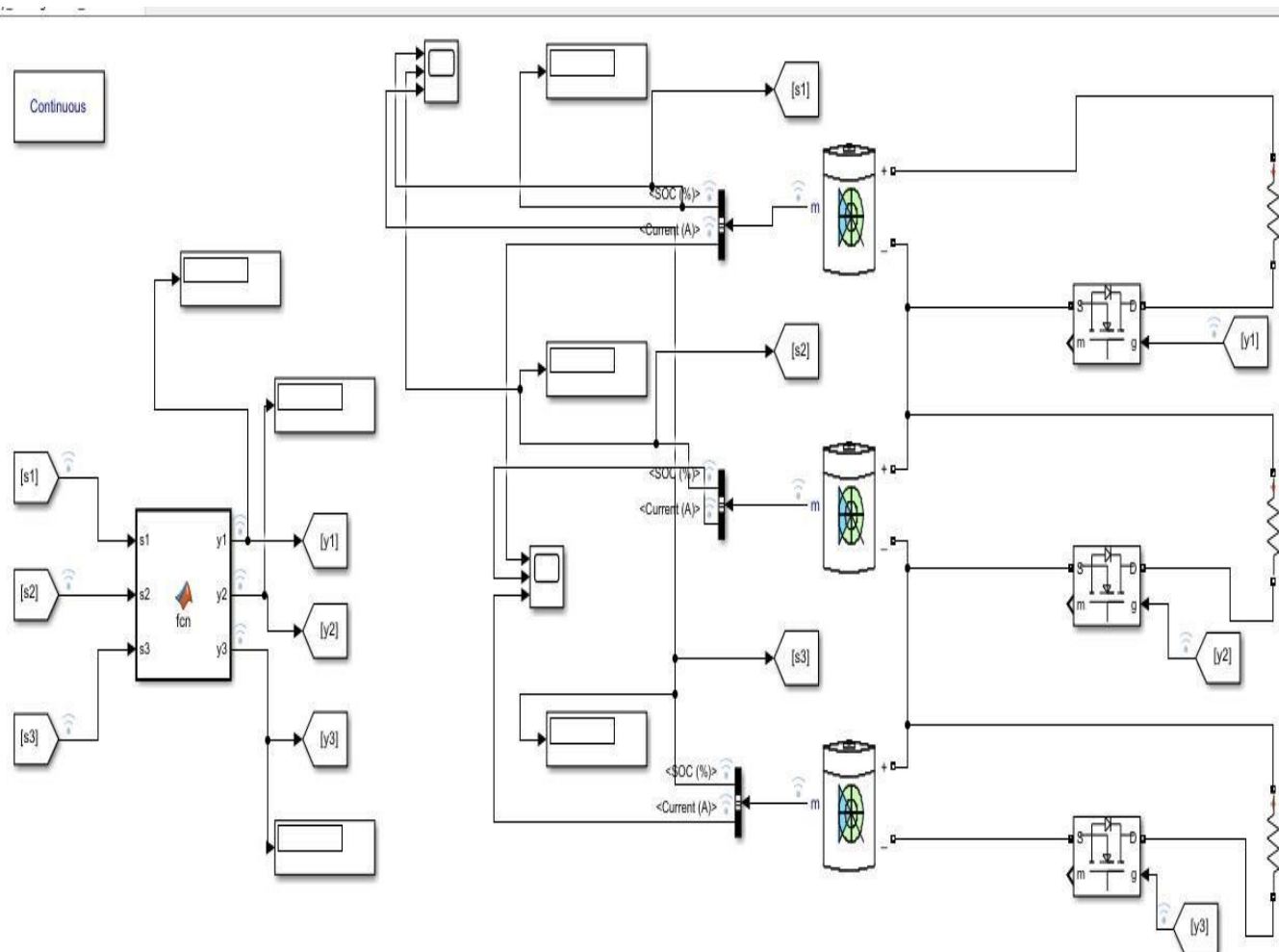

## CONCLUSION

In this way, we are developing a system model for Battery Management System and controlling based on 3 parameters voltage, current and Temperature . This project makes it possible to build complex and effective products at a cheaper price. Application of the same for different types of hybrid vehicles and other battery using applications. The battery management system can be Used in automation industries, automotive industries Charging a lead-acid battery can take more than 10 hours, whereas lithium ion batteries can take from 3 hours to as little as a few minutes to charge, depending on the size of the battery. Lithium ion chemistries can accept a faster rate of current, charging quicker than batteries made with lead acid

## ACKNOWLEDGEMENT:

It brings to a great pleasure in submitting with this paper with deep sense of attitude and profound respect towards a project Dr. **AMIT KUMAR SINGH** for his valuable guidance, timely support and inspiration in the completion of this dissertation entitled

“**BATTERY MANAGEMENT SYSTEM USING LITHIUM ION AND LEAD ACID BATTERY**”.

## REFERENCES:

- [1.] <http://ww1.microchip.com/downloads/en/AppNotes/00231a.pdf>
- [2.] Tie, S.F. and C.W. Tan, *A review of energy sources and energy management system in electric vehicles*. Renewable and Sustainable Energy Reviews, 2013. **20**: p. 82-102.
- [3] Xuebing Han , Minggao Ouyang, Languang Lu , Jianqiu Li. *A comparative study of commercial lithium ion battery cycle life in electric vehicle:Capacity loss estimation*. J. Power Sources 2014;268:658–69. [4] [Barsukov, Yevgen; Qian, Jinrong\(May 2013\). Battery Power Management for Portable Devices.ISBN 9781608074914](#)