



Effect of particle contamination on the partial discharge characteristics of pressurized air

Ravi Prasad D¹

Asst. Professor, Department of EEE

Sri Siddhartha Institute of technology

SSAHE, Tumakuru, India

B.Rajesh Kamath²

Professor, Department of EEE

Sri Siddhartha Institute of technology

SSAHE, Tumakuru, India

Mandara. R³

Student, Department of EEE

Sri Siddhartha Institute of technology

SSAHE, Tumakuru, India

Veeresh Kumar B⁴

Student, Department of EEE

Sri Siddhartha Institute of technology

SSAHE, Tumakuru, India

Abstract—Partial Discharge (PD) characteristics of particles in gas plays a major role in the High Voltage Engineering. PD give rise to weak insulation leading to breakdown gradually in the system. The Gas Insulated substation (GIS) and gas insulated transmission line (GIL) uses sulphur hexa fluoride (SF₆). The later is considered to be the greenhouse gas. The environmentalists and power engineers have seriously considered the contribution of SF₆ gas to ozone depletion and the global greenhouse effect with a global warming potential (GWP) of 23,900 times that of Carbon-di-oxide. SF₆ is believed to form highly toxic and corrosive compounds when subjected to electrical discharges. Due to these drawbacks of SF₆, there is a strong urge worldwide that users actively pursue means to minimize the release of SF₆ into the environment. Pressurized air can be another alternative for SF₆. The investigation on the behaviour of air at different pressures can be observed with different particle contaminant.

This paper presents the PD characteristics of particles in pressurized air. It projects various parameters like PD inception voltage, peak charge values and PD patterns in 3D view. This paper depicts power dissipation in μ watts and shows the PD activity in different phase angles of the applied voltage.

Keywords—Partial Discharge, Gas Insulated substation, Gas Insulated Transmission Line, Sulphur Hexa Fluoride, Global Warming Potential

I. INTRODUCTION

Pressurized air can be an alternative for SF₆, though air is no match for SF₆ in terms of electrical properties, there can be a thorough study of the later for different pressures. Since SF₆ is a potent gas with GWP 23900 times of CO₂, there is a worldwide urge to reduce the use of SF₆ as electrical insulation. An alternative of the later is being investigated for over a decade and have come up with different gases and gas mixtures. The recent being the one being tested by ABB [6].

Since most of the alternatives for SF₆ used carbon di oxide (CO₂) with CF₃I (Trifluoroiodomethane), C₄-fluoronitrile and C₅-Fluoroketones[6] The main component of the mixture up to 90% is CO₂. Though there is a concern on using CO₂, because of global warming, the later has to be used because of its properties and easy availability.

The particle contamination in any gaseous dielectric is the major cause for the partial discharges which in turn cause the insulation failure [7]. The particle contamination inside the GIS may occur because of the manufacturing process, from mechanical vibrations, moving parts of the system such as breakers. It can also be from the negligence during the maintenance inside the GIS or from corrosion or decomposition of the metallic products [1]. The study of PD characteristics for different gas pressure and different particle contaminants can give a real picture of the dielectric strength of insulating medium used in GIS as an alternative for SF₆. The study of PD characteristics for air at different pressures and particles can be taken as reference and compared with other gases like N₂, CO₂ and their gas mixtures.

II. EXPERIMENTAL DETAILS

The experimental set up is a straight detector with discharge free transformer and coupling capacitor in parallel connection with the test object. The analog signal of voltage waveform and the PD pulses are captured through MPD 600 an advanced Partial Discharge Measuring and Analysis System device and is connected through fiber optic cable to USB502 device which converts analog to digital data, which in turn is connected to laptop or desktop. The digital data can be analyzed using OMICRON software.

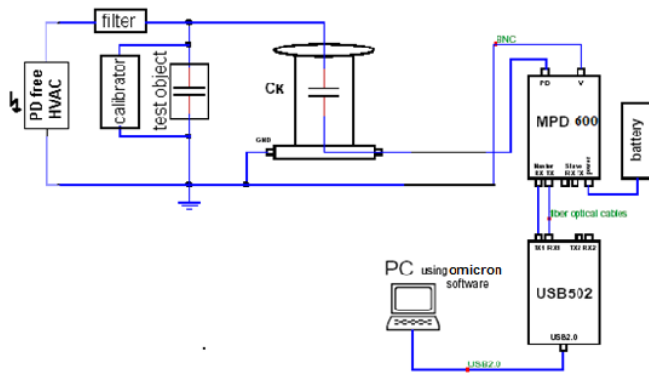

Fig.1 Circuit for discharge measurement



Fig.2 Photograph of the test setup

The compressor is used for filling air at different pressures. The test setup has arrangements for both AC/DC voltages. The pressurized chamber is fitted with a micrometer for gap distance measurement was specially designed for this test. The experimentation was conducted only for AC voltages and a point – plane electrode configuration was used to create non-uniform field.

Investigation were made using conducting and non conducting particles for different gap distance and air pressure. The PD characteristics for air at normal pressure with different conducting like Copper and Aluminium [1], insulating materials like Acrylic, Teflon and Poly Propylene spacer of different thickness were investigated for PD inception voltages. The PD characteristics for air at 0.1 MPa with different particle contamination for different gap spacing like 5mm, 7.5mm, 10mm, 12.5mm and 15mm is investigated. The PD characteristics for air at 0.2 MPa with different particle contamination for different gap spacing like 5mm, 7.5mm, 10mm, 12.5mm and 15mm is investigated.

III. EXPERIMENTAL PROCEDURE

The test set up is calibrated for discharge pulse using the calibrator provided by M/S OMICRON energy. The point – plane electrode configuration are cleaned to minimize surface deposition and oxide deposits. The top conductor is connected to ac supply and bottom conductor is to be grounded. The copper particle/aluminum particle is placed on the lower plate electrode and gap distance is adjusted for different readings like 5mm, 7.5mm, 10mm, 12.5mm and 15mm using screw gauge provided inside the chamber. The voltage is increased using the control panel and the PD inception voltage is captured and noted down for various gap distances and particles. Further spacers of different thickness 5mm, 7.5mm, 10mm, 12.5mm and 15mm are placed in between the same electrode combination without gap and PD inception voltage and various discharge pattern are observed.

The pressure of the air is increased using a compressor for 0.1MPa and 0.2MPa [1] and the same experimental procedure is followed for different particle and gap distances.

Various data including voltage waveforms, PD pulses, phase angle, power dissipated, etc which are captured are analyzed using the OMICRON software.

IV. Results and Discussion

The dimensions of the particles used for the investigation and data related to pressure, gap distances and PD inception voltages are given in the table below. The 2D and 3D histograms for various gap distances for different particles were analyzed. The phase angle at which the PD activity was more and the corresponding power dissipation were also investigated to all the readings shown in the table. In this paper only one gap distance was considered for analysis of various particles at different pressures.

TABLE 1. TABLE FOR PD INCEPTION VOLTAGES

Non Uniform Field Created using Point-Plane Electrode Point (60, 2mm Tip) Plane (60 mm Φ)	Conducting Particle (0.8 mm Φ, 10 mm length)		Insulating Particle Diameter: 40 mm Φ Thickness : 5mm, 7.5mm, 10mm, 12.5mm, 15mm		
	Copper PD Inception Voltage kV Average Charge (Q) pC	Aluminium PD Inception Voltage kV Average Charge (Q) pC	Acrylic PD Inception Voltage kV Average Charge (Q) pC	Teflon PD Inception Voltage kV Average Charge (Q) pC	Polypropylene PD Inception Voltage kV Average Charge (Q) pC
Air at Normal Pressure 0.091MPa (690mmHg)					
Gap Distance 5mm	PD _{avg} = 1.566 Q _{avg} = 13.13 Q _{peak} = 539.8	PD _{avg} = 2.74 Q _{avg} = 14.52 Q _{peak} = 551.1	PD _{avg} = 2.69 Q _{avg} = 14.69 Q _{peak} = 442.4	PD _{avg} = 3.55 Q _{avg} = 13.84 Q _{peak} = 587.6	PD _{avg} = 3.518 Q _{avg} = 24.28 Q _{peak} = 452.1
Gap Distance 7.5mm	PD _{avg} = 3.27 Q _{avg} = 18.61 Q _{peak} = 381	PD _{avg} = 4.9 Q _{avg} = 13.9 Q _{peak} = 353.8	PD _{avg} = 3.77 Q _{avg} = 27.02 Q _{peak} = 570.7	PD _{avg} = 3.98 Q _{avg} = 13.95 Q _{peak} = 259.1	PD _{avg} = 2.251 Q _{avg} = 14.24 Q _{peak} = 538.3
Gap Distance 10mm	PD _{avg} = 2.59 Q _{avg} = 13.46 Q _{peak} = 576.1	PD _{avg} = 3.63 Q _{avg} = 10.27 Q _{peak} = 388.4	PD _{avg} = 4.06 Q _{avg} = 15.26 Q _{peak} = 539.6	PD _{avg} = 2.182 Q _{avg} = 13.3 Q _{peak} = 419.5	PD _{avg} = 3.441 Q _{avg} = 17.28 Q _{peak} = 575.2
Gap Distance 12.5mm	PD _{avg} = 2.305 Q _{avg} = 13.82 Q _{peak} = 514.5	PD _{avg} = 2.47 Q _{avg} = 13.96 Q _{peak} = 72.67	PD _{avg} = 3.53 Q _{avg} = 14.35 Q _{peak} = 769.15	PD _{avg} = 3.914 Q _{avg} = 14.57 Q _{peak} = 675.3	PD _{avg} = 4.06 Q _{avg} = 15.06 Q _{peak} = 628.7
Gap Distance 15mm	PD _{avg} = 1.99 Q _{avg} = 107 Q _{peak} = 571	PD _{avg} = 2.99 Q _{avg} = 10.42 Q _{peak} = 381.4	PD _{avg} = 4.115 Q _{avg} = 15.64 Q _{peak} = 698.1	PD _{avg} = 3.22 Q _{avg} = 14.22 Q _{peak} = 571.6	PD _{avg} = 2.37 Q _{avg} = 14.86 Q _{peak} = 162.2
Air Pressure 0.1MPa					
Gap Distance 5mm	PD _{avg} = 3.754 Q _{avg} = 14.59 Q _{peak} = 382.4	PD _{avg} = 4.34 Q _{avg} = 14.6 Q _{peak} = 257	PD _{avg} = 2.69 Q _{avg} = 14.69 Q _{peak} = 442.4	PD _{avg} = 3.55 Q _{avg} = 13.84 Q _{peak} = 587.6	PD _{avg} = 3.518 Q _{avg} = 24.28 Q _{peak} = 452.1
Gap Distance 7.5mm	PD _{avg} = 3.20 Q _{avg} = 14.59 Q _{peak} = 382.4	PD _{avg} = 4.06 Q _{avg} = 14.28 Q _{peak} = 303	PD _{avg} = 3.77 Q _{avg} = 27.02 Q _{peak} = 570.7	PD _{avg} = 3.98 Q _{avg} = 13.95 Q _{peak} = 259.1	PD _{avg} = 2.251 Q _{avg} = 14.24 Q _{peak} = 538.3
Gap Distance 10mm	PD _{avg} = 2.737 Q _{avg} = 13.57 Q _{peak} = 511.5	PD _{avg} = 3.2 Q _{avg} = 13.71 Q _{peak} = 458	PD _{avg} = 4.06 Q _{avg} = 15.26 Q _{peak} = 539.6	PD _{avg} = 2.182 Q _{avg} = 13.3 Q _{peak} = 419.5	PD _{avg} = 3.441 Q _{avg} = 17.28 Q _{peak} = 575.2
Gap Distance 12.5mm	PD _{avg} = 3.232 Q _{avg} = 14.34	PD _{avg} = 2.66 Q _{avg} = 14.24 Q _{peak} = 387.7	PD _{avg} = 3.53 Q _{avg} = 14.35 Q _{peak} =	PD _{avg} = 3.914 Q _{avg} = 14.57	PD _{avg} = 4.06 Q _{avg} = 15.06 Q _{peak} = 628.7

Gap Distance 15mm	PD _{inception} = 1.99 Q _{avg} = 107 Q _{peak} = 571	PD _{inception} = 2.99 Q _{avg} = 10.42 Q _{peak} = 381.4	PD _{inception} = 4.115 Q _{avg} = 15.64 Q _{peak} = 698.1	PD _{inception} = 3.22 Q _{avg} = 14.22 Q _{peak} = 571.6	PD _{inception} = 2.37 Q _{avg} = 14.86 Q _{peak} = 162.2
Air Pressure 0.1MPa					
Gap Distance 5mm	PD _{inception} = 3.754 Q _{avg} = 14.59 Q _{peak} = 382.4	PD _{inception} = 4.34 Q _{avg} = 14.6 Q _{peak} = 257	PD _{inception} = 2.69 Q _{avg} = 14.69 Q _{peak} = 442.4	PD _{inception} = 3.55 Q _{avg} = 13.84 Q _{peak} = 587.6	PD _{inception} = 3.518 Q _{avg} = 24.28 Q _{peak} = 452.1
Gap Distance 7.5mm	PD _{inception} = 3.20 Q _{avg} = 14.59 Q _{peak} = 382.4	PD _{inception} = 4.06 Q _{avg} = 14.28 Q _{peak} = 303	PD _{inception} = 3.77 Q _{avg} = 27.02 Q _{peak} = 570.7	PD _{inception} = 3.98 Q _{avg} = 13.95 Q _{peak} = 259.1	PD _{inception} = 2.251 Q _{avg} = 14.24 Q _{peak} = 538.3
Gap Distance 10mm	PD _{inception} = 2.737 Q _{avg} = 13.57 Q _{peak} = 511.5	PD _{inception} = 3.2 Q _{avg} = 13.71 Q _{peak} = 458	PD _{inception} = 4.06 Q _{avg} = 15.26 Q _{peak} = 539.6	PD _{inception} = 2.182 Q _{avg} = 13.3 Q _{peak} = 419.5	PD _{inception} = 3.441 Q _{avg} = 17.28 Q _{peak} = 575.2
Gap Distance 12.5mm	PD _{inception} = 3.232 Q _{avg} = 14.34 Q _{peak} = 356.7	PD _{inception} = 2.66 Q _{avg} = 14.24 Q _{peak} = 387.7	PD _{inception} = 3.53 Q _{avg} = 14.35 Q _{peak} = 769.15	PD _{inception} = 3.914 Q _{avg} = 14.57 Q _{peak} = 675.3	PD _{inception} = 4.06 Q _{avg} = 15.06 Q _{peak} = 628.7
Gap Distance 15mm	PD _{inception} = 2.802 Q _{avg} = 13.41 Q _{peak} = 392	PD _{inception} = 1.5 Q _{avg} = 13.78 Q _{peak} = 350.2	PD _{inception} = 4.115 Q _{avg} = 15.64 Q _{peak} = 698.1	PD _{inception} = 3.22 Q _{avg} = 14.22 Q _{peak} = 571.6	PD _{inception} = 2.37 Q _{avg} = 14.86 Q _{peak} = 162.2
Air Pressure 0.2MPa					
Gap Distance 5mm	PD _{inception} = 5.48 Q _{avg} = 14.64 Q _{peak} = 331	PD _{inception} = 4.11 Q _{avg} = 284 Q _{peak} = 14.42	PD _{inception} = 3.77 Q _{avg} = 27.02 Q _{peak} = 570.7	PD _{inception} = 3.98 Q _{avg} = 13.95 Q _{peak} = 259.1	PD _{inception} = 2.251 Q _{avg} = 14.24 Q _{peak} = 538.3
Gap Distance 7.5mm	PD _{inception} = 3.902 Q _{avg} = 14.16 Q _{peak} = 263.7	PD _{inception} = 2.84 Q _{avg} = 13.58 Q _{peak} = 349.1	PD _{inception} = 4.06 Q _{avg} = 15.26 Q _{peak} = 539.6	PD _{inception} = 2.182 Q _{avg} = 13.3 Q _{peak} = 419.5	PD _{inception} = 3.441 Q _{avg} = 17.28 Q _{peak} = 575.2
Gap Distance 10mm	PD _{inception} = 2.355 Q _{avg} = 13.22 Q _{peak} = 489.2	PD _{inception} = 4.55 Q _{avg} = 14.79 Q _{peak} = 292.9	PD _{inception} = 3.53 Q _{avg} = 14.35 Q _{peak} = 769.15	PD _{inception} = 3.914 Q _{avg} = 14.57 Q _{peak} = 675.3	PD _{inception} = 4.06 Q _{avg} = 15.06 Q _{peak} = 628.7
Gap Distance 12.5mm	PD _{inception} = 3.472 Q _{avg} = 14.01 Q _{peak} = 347.9	PD _{inception} = 4.36 Q _{avg} = 14.03 Q _{peak} = 406.8	PD _{inception} = 4.115 Q _{avg} = 15.64 Q _{peak} = 698.1	PD _{inception} = 3.22 Q _{avg} = 14.22 Q _{peak} = 571.6	PD _{inception} = 2.37 Q _{avg} = 14.86 Q _{peak} = 162.2
Gap Distance 15mm	PD _{inception} = 3.131 Q _{avg} = 14.10 Q _{peak} = 422.8	PD _{inception} = 3.415 Q _{avg} = 27.94 Q _{peak} = 501.9	PD _{inception} = 2.69 Q _{avg} = 14.69 Q _{peak} = 442.4	PD _{inception} = 3.55 Q _{avg} = 13.84 Q _{peak} = 587.6	PD _{inception} = 3.518 Q _{avg} = 24.28 Q _{peak} = 452.1

The above table gives the PD inception voltage for various particle, gap distances and pressure. It also highlights the peak charge Q_p and average charge Q_{avg} in coulombs. For discussion and analysis, only 5mm gap distance for conducting copper particle at 0.09MPa, 0.1 MPa and 0.2 MPa air pressure is shown in this paper. Also for insulating particle Teflon of 5 mm thickness is elaborated. In compliance with international standard IEC 60270

A). PD characteristics with Copper particle (0.8mm Φ , 10mm length) as contaminant at 0.09MPa (690mmHg) of Air as insulating media is shown below



Fig.3 2D histogram for Cu particle with 5mm gap distance

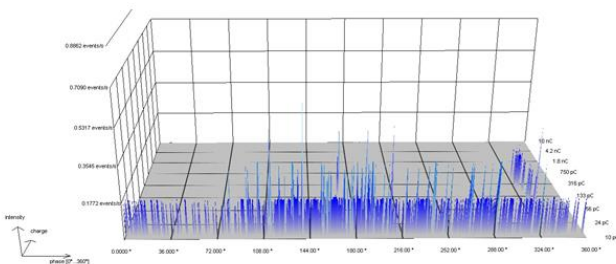

Fig.4 3D histogram for Cu particle with 5mm gap distance

With Cu particle of length 1.0 mm and diameter of 0.8mm Φ as contamination, the partial discharges were found at inception voltages of 1.392 kV(RMS) Figure 3, shows the 2D histogram of a gas chamber chamber consisting of Cu particle as contaminant, in Air 0.091 MPa pressure and its 3D histogram is shown in Figure 4. At 0.091MPa, the PD activity is observed to be more prominent under negative half cycle of ac as seen in the histograms. If we consider Figure 3, in relation to the intensity chart furnished, the discharges seen having PD magnitude of 23.62 pC are due to PDs of intensity 0.354PDs/Sec and 0.531 PDs/sec. But corresponding values on the negative cycle are very insignificant. Hence, under the given experimental condition, PD during negative half cycle is very dominant. This may be attributed to the roughness of the central conductor. The results are duly supported by the 3D histogram in Figure 4. The pulse repetition rate “n” is 128.1 PDs/s as seen from statistics display in Figure 5. The power dissipated is 3.439 μ W. This shows that the pulses are more when compared to clean environment without particle contamination.



Fig.5 2D histogram for Cu particle with 5mm gap distance

Similarly the PD characteristics for inception voltages of 1.1 times and 1.2 times can be captured and studied for further studies if necessity in two dimensional and three dimensional histogram for 5 mm gap distances. The discharge increases causing the insulation to breakdown in the gap at 9.33kV (RMS).

B). PD characteristics with Copper particle (0.8mm Φ , 10mm length) as contaminant at 0.1MPa of Air as insulating media is shown below

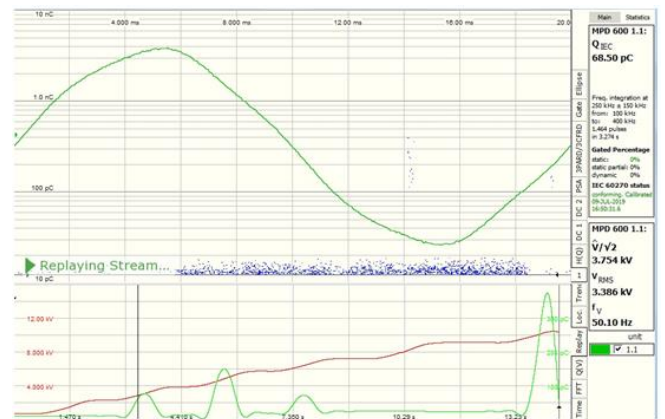

Fig.6 2D histogram for Cu particle with 5mm gap distance at 0.1 MPa

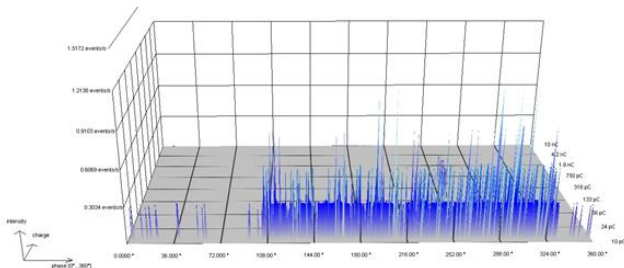

Fig.7 3D histogram for Cu particle with 5mm gap distance at 0.1 MPa

With Cu particle of length 1.0 mm and diameter of 0.8mm Φ as contamination, the partial discharges were found at inception voltages of 3.386 kV(RMS). Figure 6, shows the 2D histogram of a gas chamber consisting of Cu particle as contaminant, in Air 0.1 MPa pressure and its 3D histogram is shown in Figure 7. At 0.1MPa, the PD activity is observed to be more prominent under negative half cycle of ac as seen in the histograms. If we consider Figure 6, in relation to the intensity chart furnished, the discharges seen having PD magnitude of 68.5 pC are due to PDs of intensity 0.2432PDs/Sec and 0.4864 PDs/sec. But corresponding values on the negative cycle are very insignificant. Hence, under the given experimental condition, PD during negative half cycle is very dominant. This may be attributed to the roughness of the central conductor. The results are duly supported by the 3D histogram in Figure7. The pulse repetition rate “n” is 401.1 PDs/s as seen from statistics display in Figure 8. The power dissipated is 21.02 μ W. This shows that the pulses are more when compared to clean environment without particle contamination and also power dissipation is more when compared to air at room pressure. Significant PD can be seen between the phase angles 108⁰ to 324⁰.



Fig.8 2D histogram for Cu particle with 5mm gap distance at 0.1 MPa

The results are that the pulses intensity is in the zone of 0.243 to 0.486 pulses/sec . The discharge increases causing a the insulation to breakdown in the gap at 9.33kV (RMS). Similarly the PD characteristics at inception voltages has been captured and studied in two dimensional and three dimensional histogram for 7.5mm, 10mm, 12.5mm, 15 mm gap distances at 0.1MPa gas pressure

C). PD characteristics with Copper particle (0.8mm Φ , 10mm length) as contaminant at 0.2MPa of Air as insulating media is shown below

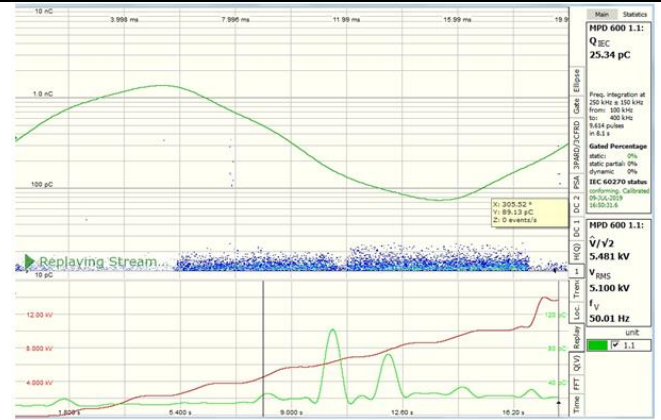

Fig.9 2D histogram for Cu particle with 5mm gap distance at 0.2MPa

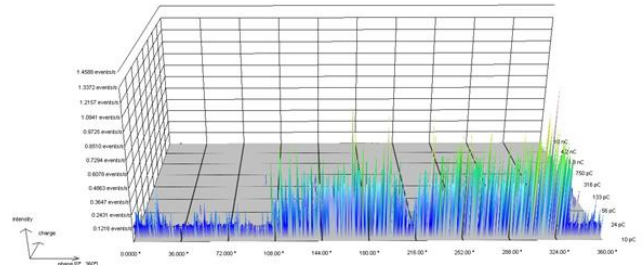

Fig.10 3D histogram for Cu particle with 5mm gap distance at 0.2 MPa

With Cu particle of length 10mm and diameter of 0.8 mm Φ as contamination, the partial discharges were found at inception voltages of 5.48kV(RMS). Figure 9, shows the 2D histogram of a gas chamber consisting of, Air 0.2 MPa pressure and its 3D histogram is shown in Figure 10. At 0.2 MPa, the PD activity is observed to be more prominent under positive cycle of ac as seen in the histograms. The number of PD events is 0.364 PDs/sec (maximum) in case of the positive half cycle whereas, it is about 0.6078 PDs/sec in the negative half cycle. Even the spread of discharge magnitude is larger during the positive half cycle. If we consider Figure 9, in relation to the intensity chart furnished, the discharges seen having PD magnitude of 25.34 pC are due to PDs of intensity 0.364 PDs/sec to 0.6078 PDs/sec. Hence, under the given experimental condition, PD during negative half cycle is very dominant. This may be attributed to the roughness of the central conductor. The results are duly supported by the 3D histogram in Figure 10. The pulse repetition rate “n” is 1.033kPDs/s as seen from statistics display in Figure 11. This shows that the pulses are more when compared to clean environment without particle contamination. The PD activity is more in the phase angle between 108⁰ to 324⁰. The power dissipated is 65.49 μ W.

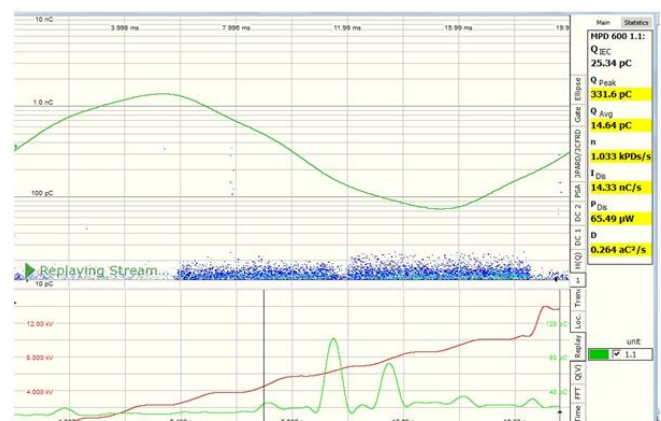

Fig.11 2D histogram for Cu particle with 5mm gap distance at 0.2MPa

The results are that the pulses intensity is in the zone of 0.3647 to 0.6078 pulses/sec. The discharge increases causing a the voltage breakdown at 11.83kV (RMS).

Similarly the PD characteristics at inception voltages has been captured and studied in two dimensional and three

The combination is point -plane electrodes with thickness of spacers as 5mm and diameter 40mm Φ .



Fig.12 2D histogram for Teflon spacer with 5mm thickness and 40mm Φ

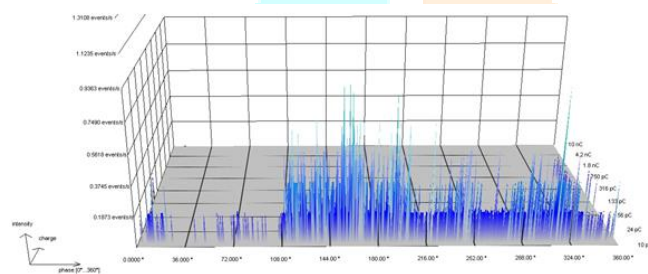

Fig.13 3D histogram for Teflon spacer with 5mm thickness and 40mm Φ

With Teflon spacer of 5mm thickness and diameter of 40mm Φ , act as a non-conducting particle, the partial discharges were found at inception voltages of 3.204kV(RMS). Figure 12, shows the 2D histogram of a gas chamber consisting of normal pressure and its 3D histogram is shown in Figure 13. At normal pressure, the PD activity is observed to be more prominent under positive cycle of ac as seen in the histograms. The number of PD events is 0.749 PDs/sec (maximum) in case of the positive half cycle whereas, it is about 0.5618 PDs/sec in the negative half cycle. Even the spread of discharge magnitude is larger during the positive half cycle. If we consider Figure 12, in relation to the intensity chart furnished, the discharges seen having PD magnitude of 76.53 pC are due to PDs of intensity 0.516 PDs/sec to 0.749 PDs/second. Hence, under the given experimental condition, PD during positive half cycle is very dominant. This may be attributed to the surface discharge on the spacer. The results are duly supported by the 3D histogram in Figure 15. The pulse repetition rate "n" is 353.9PDs/s as seen from statistics display in Figure 16. This shows that the pulses are more between phase angles 108⁰ to 180⁰ during positive cycle and between 180⁰ to 324⁰. The power dissipated is 12.20 μ W. The results are that the pulses intensity is in the zone of 0.749 PDs/sec to 0.5618 PDs/sec.

Similarly the PD characteristics for inception voltages of for acrylic and polypropylene spacers for different dimensions were also analyzed.

The discharge increases causing the voltage breakdown at 12.45kV (RMS).

dimensional histogram for 7.5mm, 10mm, 12.5mm, 15 mm gap distances at 0.2MPa air pressure.

D) PD characteristics with Teflon spacer at normal pressure 0.09MPa(690mmHg) of Air as insulating media.



Fig.14 3D histogram for Teflon spacer with 5mm thickness and 40mm Φ

V. Conclusion

It was observed that the results for clean insulation with out contamination shows inception voltage much lesser than the environment with particle contamination. Further when the voltages were increased there were significant amount of PD activity with lots of discharges in the negative half cycle. The reason being the increased voltages. It was observed that the PD inception voltage with Cu particle was more than that of the clean environment with out particle contamination. The major reason being the corona at the rough surfaces. Further the Cu particle with 5mm gap distance exhibited higher inception voltage as the gas pressure were increase from normal pressure of 0.091 MPa to 0.1 MPa and 0.2 MPa. Power dissipation increased from 3 μ W to 65 μ W as the pressure of gas was increased from normal pressure to 0.2MPa. The PD activity was predominant in the negative half cycle for most of the study with different parameter with intensity more between phase angles 180⁰ to 324⁰ in general. The Teflon spacers exhibited higher PD inception voltages compared to conducting particle contaminants. Power dissipation with Teflon spacers was around 12.2 μ W, as compared to 3.49 μ W in case of copper particle. This accounts mainly because of surface discharge on Teflon. PD activity was found to be more in positive cycle with Teflon spacers as compared to predominant activity in negative cycle for Cu particle.

REFERENCES

- [1] B. Rajesh Kamath, J. Sundara Rajan, K. A Krishnamurthy, m. Z Kurian, " Partial Discharge characteristics of Nichrome Particle in a Gas Filled Duct", Proceedings of World Congress on Engineering and computer Science 2013 Vol I, WCECS 2013, 23-25 October, 2013, San Fransisco, USA.
- [2] Morcos M. M., Ward S. A., Anis H., Srivastava K. D. And Gubanski S. M., "Insulation Integrity of GIS/GITL Systems and Management of Particle Contamination", IEEE Electr. Insul. Magazine, Vol. 16, No. 5, pp. 25-37, 2000.
- [3] M. Abdul Salam, P. Weiss and B. Lieake, "Discharge in air from point electrodes in the presence of dielectric plates," IEEE. Trans. Elec. Insulation, Vol.27 (2), pp. 309-319 April 1992.
- [4] T. S. Sudharshan and R. A. Dougal "Mechanisms of surface flash over along solid dielectrics in compressed gasses: A review", IEEE Trans Elec. Insul. Vol. EI 21 (5), Oct. 1986
- [5] Chakrabarty A. K., Van Heeswijk R. G. and Srivastava K. D., "Spacer

Involvement in the Conducting Particle Initiated Breakdown in Compressed Gas Insulated Systems”, IEEE Trans. Electr. Insul. Mag., Vol. 22, No. 4, pp. 431-438, 1987.

- [6] “Breakthroughs in Switchgear technology with eco-efficient gases as an alternative to SF₆.” <https://library.e.abb.com/public>.
- [7] Mantilla J.D Claessens M., Gariboldi., Grob S., “Investigation of Insulation Performance of a New Gas mixture with extremely low GWP”, IEEE 2014 Electrical Insulation Conference, Philadelphia PA, USA, pp469-473.

