



SINUSOIDAL COMMUTATION OF THREE PHASE BRUSHLESS DC MOTOR USING LOW-COST LINEAR HALL EFFECT SENSORS

VARUN JOSE , Asst.Professor

Department of Electrical & Electronics Engineering
S.C.M.S School of Engineering & Technology, Kerala, India

Abstract: Torque ripples in BLDC motor can be eliminated to a great extent by implementing sinusoidal commutation. The paper presents a Low-cost Sinusoidal Commutation drive for BLDC motor actuator for 3rd stage of the PSLV. The method implemented as part of paper uses Linear Hall Sensors to sense the magnetic field intensity and thereby use this information to generate the gating signals. The technique of implementation proposed in [1] is used to drive the BLDC motor in this paper. This method has the advantage of being simple and implementation flexibility. Also the use of Linear Hall Sensors in driving sinusoidally commutated BLDC motors is proposed in [2]. This work uses the information from the Linear Hall Sensors to get the information about the rotor position in conjunction with proposed technique in [2] to drive the sinusoidally commutated BLDC motor actuator system. The simulation of mentioned work is realized in MATLAB SIMULINK. The implementation of proposed method is done using analog control circuits.

Key words : BLDC, SIMULINK, PWM, EPROM.

I. INTRODUCTION

In Sinusoidal commutation BLDC motor controllers drive the 3 phase motor winding's with 3 phase currents that vary sinusoidally & smoothly as the rotor rotates eliminating torque ripples, commutation spikes present if trapezoidal commutation is employed. Exact information about rotor position is essential to maintain accurate sinusoidal modulation of stator currents as the rotor rotates. The ordinary hall effect sensors provides just a rough measurement of rotor position and are ineffective. High resolution sensors like absolute encoder & resolver can be used instead for extracting exact position information of the rotor. Three phase currents through the winding's can be made sinusoidal by means of PWM inverter. Since above mentioned sensors are really expensive in order to minimize the cost a sinusoidal drive system for BLDC motor has been proposed in this paper which utilizes Low Cost Linear Hall Effect sensor IC as rotor position sensor.

II. BLOCKDIAGRAM

The overall block diagram of proposed sinusoidal commutation technique is shown in **Fig 2.1**. A set of 3 linear hall effect sensors(kept 120 degrees apart) are used for position detection of rotor. The system consists of linear hall effect sensor IC's, triangular wave generator, pwm pulse generation circuit, pwm inverter, comparators for region selection as well as pwm pulse generation, driver circuit, potentiometric arrangement, PI compensator, amplifier + notch filter and current limiter

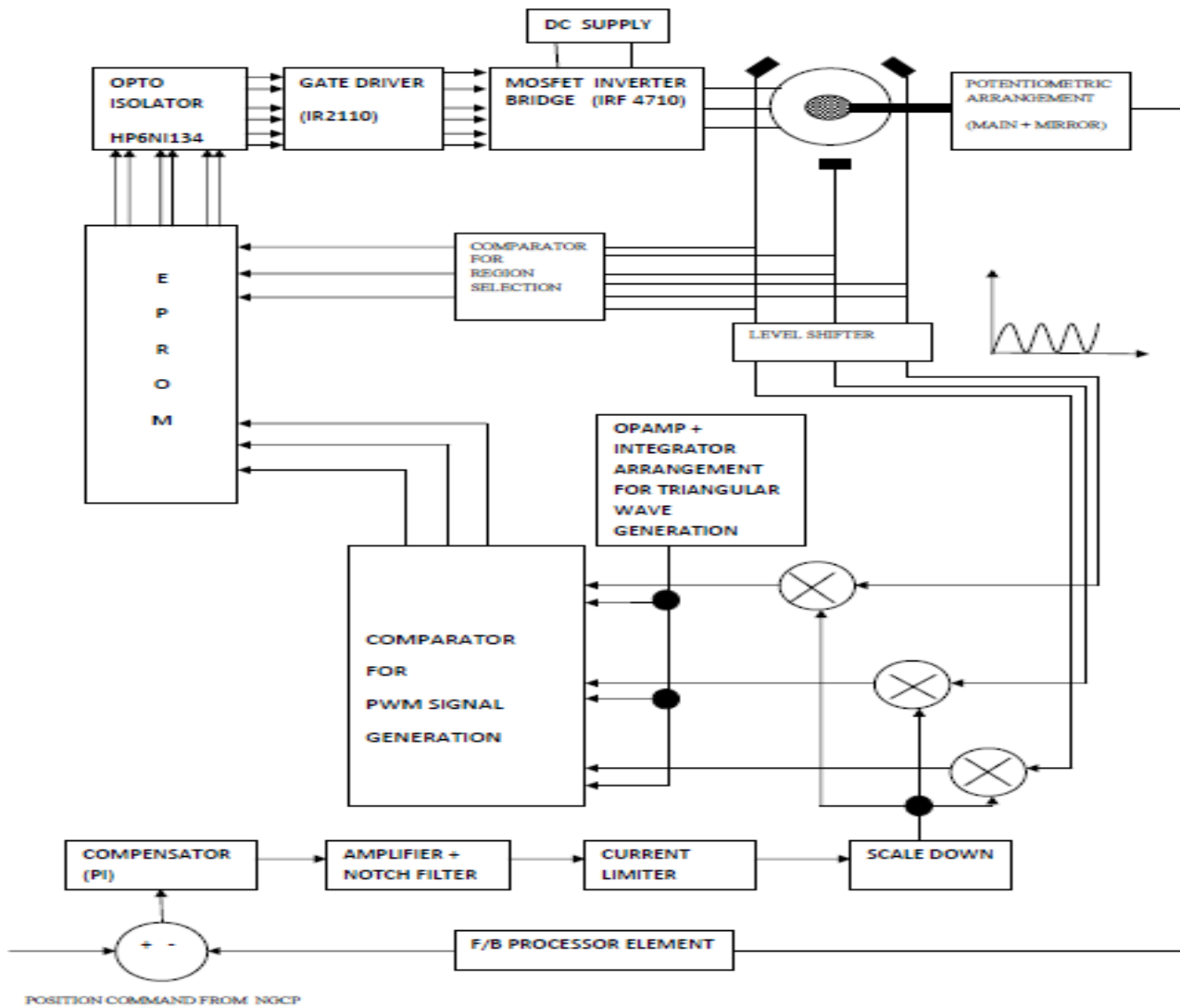

Fig 2.1 Block Diagram

2.1 PWM PULSE GENERATION LOGIC

A new pwm pulse generation logic is proposed for 3 phase voltage generation inverter used for driving the three phase BLDC motor. On analyzing the ideal three phase waveform in Fig 2.2, we can infer that the pattern of waveform in the region $(0-60)^\circ$ repeats itself in the $(120-180)^\circ$ as well as $(240-300)^\circ$. Similarly, the waveform in $(60-120)^\circ$ repeats itself in $(180-240)^\circ$ and $(300-360)^\circ$. Therefore by modulating the switches in the three phase inverter accordingly we can generate the ideal three phase output voltage waveform which is then injected to the BLDC motor stator windings.

In regions $(0-60)^\circ$, $(120-180)^\circ$ and $(240-300)^\circ$ voltage waveform in Fig 2.2 has identical pattern, 2 phase voltages are higher in magnitude than 3rd phase voltage. The following modulation technique can hence be used :-

- The MOSFET's, T_{in} ($i=a,b,c$) & (n indicates negative power rail) for phase having lesser voltage is always made to remain ON, and the respective T_{ip} ($i=a,b,c$) & (p indicates positive power rail) for the phase always remain OFF.
- The MOSFET's T_{in} ($i=a,b,c$) & (n indicates negative power rail) and T_{ip} ($i=a,b,c$) & (p indicates positive power rail) for the remaining 2 phases are triggered in complementary pattern.

While in regions $(60-120)^\circ$, $(180-240)^\circ$ and $(300-360)^\circ$ again the voltage waveforms in Fig 2.2 has identical pattern, 2 phase voltages are lesser in magnitude than 3rd phase voltage. The following modulation technique can be used :-

- The MOSFET's, T_{ip} ($i=a,b,c$) & (p indicates positive power rail) for phase with larger voltage is always made to remain ON and the respective T_{in} ($i=a,b,c$) & (n indicates negative power rail) for that phase is always made to remain OFF.
- The switches T_{ip} ($i=a,b,c$) & (p indicates positive power rail) and T_{in} ($i=a,b,c$) & (n indicates negative power rail) for the remaining two phases are driven complementary pattern.

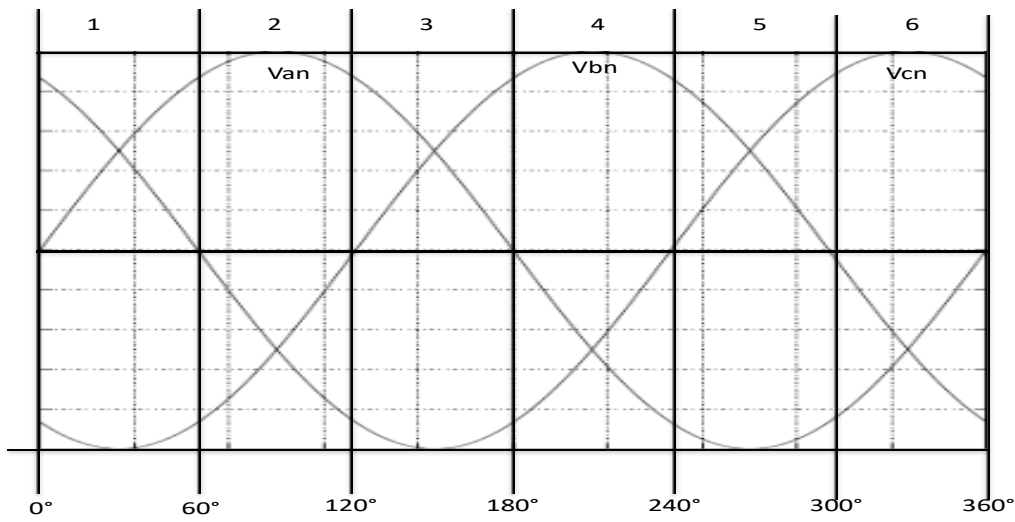

Fig 2.2 Ideal three phase waveform

Also by mutually comparing the outputs from each of the 3 linear hall effect sensors ,information about region of rotor can also be acquired.

For example : in the region (0-60)° the by mutually comparing the three linear hall sensor outputs,the outputs of each comparators will be as given below :-

$$\begin{aligned}
 &V_{Aph} > V_{Bph} = 1, \\
 &V_{Bph} > V_{Cph} = 0, \\
 &\& V_{Cph} > V_{Aph} = 1.
 \end{aligned}$$

So the binary output data from the three comparators '101' will correspond to the REGION 1 (0-60)°.

Similarly we can find out for other regions. A truth table can be formulated for each region from (0-360)° as shown in **Fig 2.4**

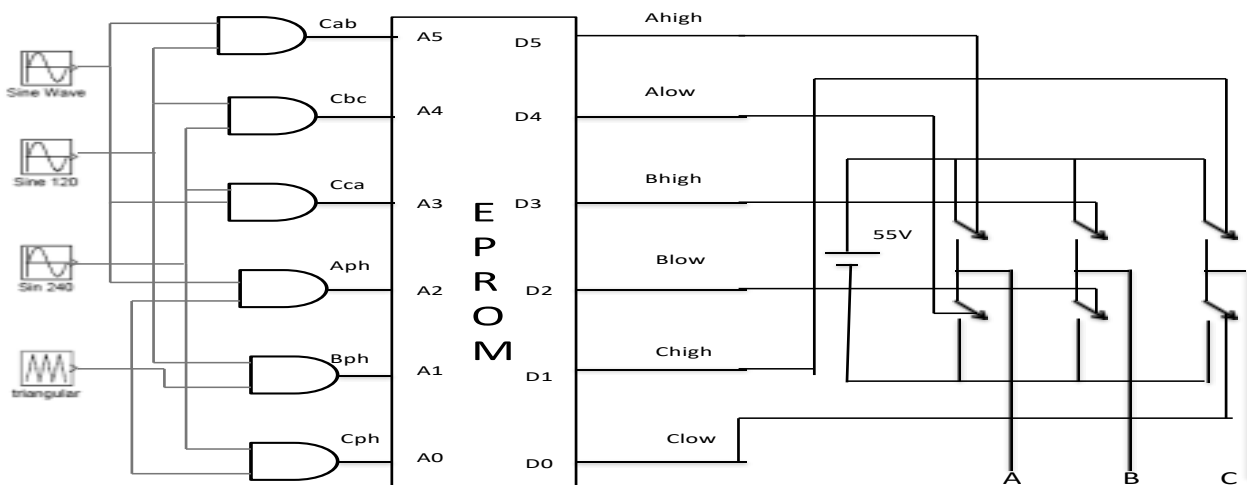

Fig 2.3 EPROM connection diagram

REGIONS	COMPARATOR O/P			PWM SIGNALS			OUTPUTS					
	A5	A4	A3	A2	A1	A0	D5	D4	D3	D2	D1	Do
	Cab	Cbc	Cca	Aph	Bph	Cph	Ahigh	Alow	Bhigh	Blow	Chigh	Clow
REGION 1 (0-60) DEG	1	0	1	0	X	0	0	1	0	1	0	1
	1	0	1	0	X	1	0	1	0	1	1	0
	1	0	1	1	X	0	1	0	0	1	0	1
	1	0	1	1	X	1	1	0	0	1	1	0
REGION 2 (60-120) DEG	1	0	0	X	0	0	1	0	0	1	0	1
	1	0	0	X	0	1	1	0	0	1	1	0
	1	0	0	X	1	0	1	0	1	0	0	1
	1	0	0	X	1	1	1	0	1	0	1	0
REGION 3 (120-180) DEG	1	1	0	0	0	X	0	1	0	1	0	1
	1	1	0	0	1	X	0	1	1	0	0	1
	1	1	0	1	0	X	1	0	0	1	0	1
	1	1	0	1	1	X	1	0	1	0	0	1

* x:-stands for don't cares can be 0 or 1 & doesn't affect output.

Fig 2.4 Truth table for pulse generation.

2.2 TRIANGULAR WAVE GENERATION CIRCUIT

A triangular waveform can be generated by integrating a square wave. Frequency of both the waveforms should be same. The triangular wave generator is a of a two level comparator in series with an integrator. Output square wave of the comparator is applied to the negative input terminal of the integrator producing a triangular wave. Through voltage divider arrangement R2-R3 triangular wave is fed back as input to the comparator .The frequency of oscillation is given by $f_o=R3/(4*R4*C*R2)$.

The frequency of the triangular wave is determined by resistor R4 and capacitor C and the amplitude is determined by R2 R3 . To avoid saturation problem at low frequencies resistor R6 is connected across capacitor C .

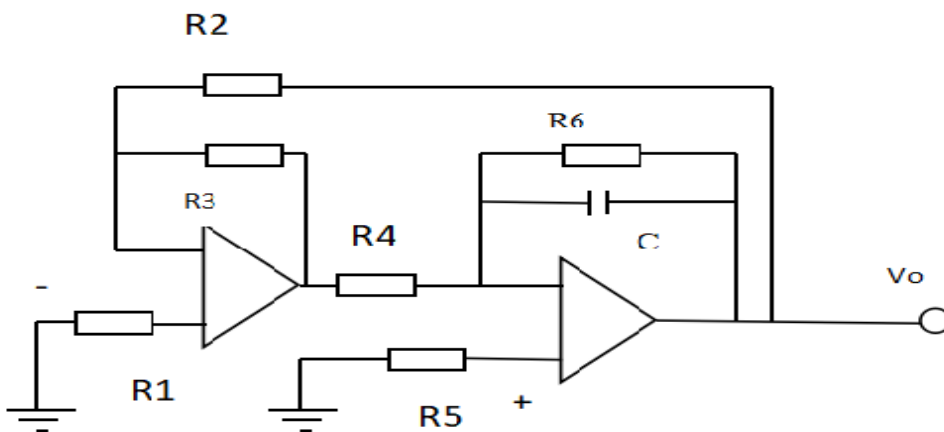

Fig 2.5 Triangular wave generator

2.3 EPROM

A EPROM NMC2764 which is UV erasable can be used to store the PWM logic as indicated in Fig 2.3. There are six inputs to the EPROM which are the three inputs to select region and another three inputs which will be the PWM signals for each phase generated by the comparator. The outputs from the EPROM will be a set of 6 gating signals to the corresponding MOSFET's in the inverter circuit.

2.4 GATEDRIVER AND INVERTER STAGE

The commutation logic circuitry also has associated circuit for generating the dead band to avoid cross conduction in any half bridge of the associated power amplifier. The commutation logic circuit has six outputs, which are the gate signals to the MOSFETs in the power amplifier stage. In order to isolate the power amplifier stage from the signal side an optical isolation is provided. The outputs of the optical isolator are fed to the gate driver chip, which provides the actual gate drive signals for the half bridge. The gate drive chip uses the bootstrap technology and generates the gate drive signals for the MOSFETs on the upper half of the bridge. The outputs from the gate driver chip are fed to the gates of the MOSFETs in the power amplifier.

2.5 OUTER POSITION LOOP

The outer position loop consists of a potentiometric arrangement (main + mirror), feed back processor element , PI compensator , amplifier + notch filter , current limiter circuit and step down arrangement. The potentiometric arrangement (main + mirror) is used to convert the linear movement of the BLDC motor actuator in to a voltage level which can be used for closed loop control . This signal is then fed to a feed back processor element .

The feedback signal is the average of two potentiometer outputs. The error between the command input and the feedback signal is amplified and is compensated by a Proportional Integral (PI) compensator. The output from the compensator is further amplified and a lag filter and a notch filter filters the output from the amplifier. This filtered output serves as the reference input for the inner loop, which is the closed loop for controlling the current flow. The feedback signal to the current loop is the voltage signal obtained from the current sense circuitry.

3.0 SIMULATION in matlab SIMULINK

The simulation of the proposed PWM pulse generation logic as well as the proposed BLDC motor drive system using low cost linear hall effect sensor has been done with the help of MATLAB SIMULINK 7.2 .

3.1 PWM PULSE GENERATION LOGIC

The three inputs to the comparators from the linear hall sensors were given using three sine wave generators as shown in the Fig 3.1 . The EPROM was simulated using a user defined block written using matlab m-file . The output pulses obtained were as shown in Fig 3.2

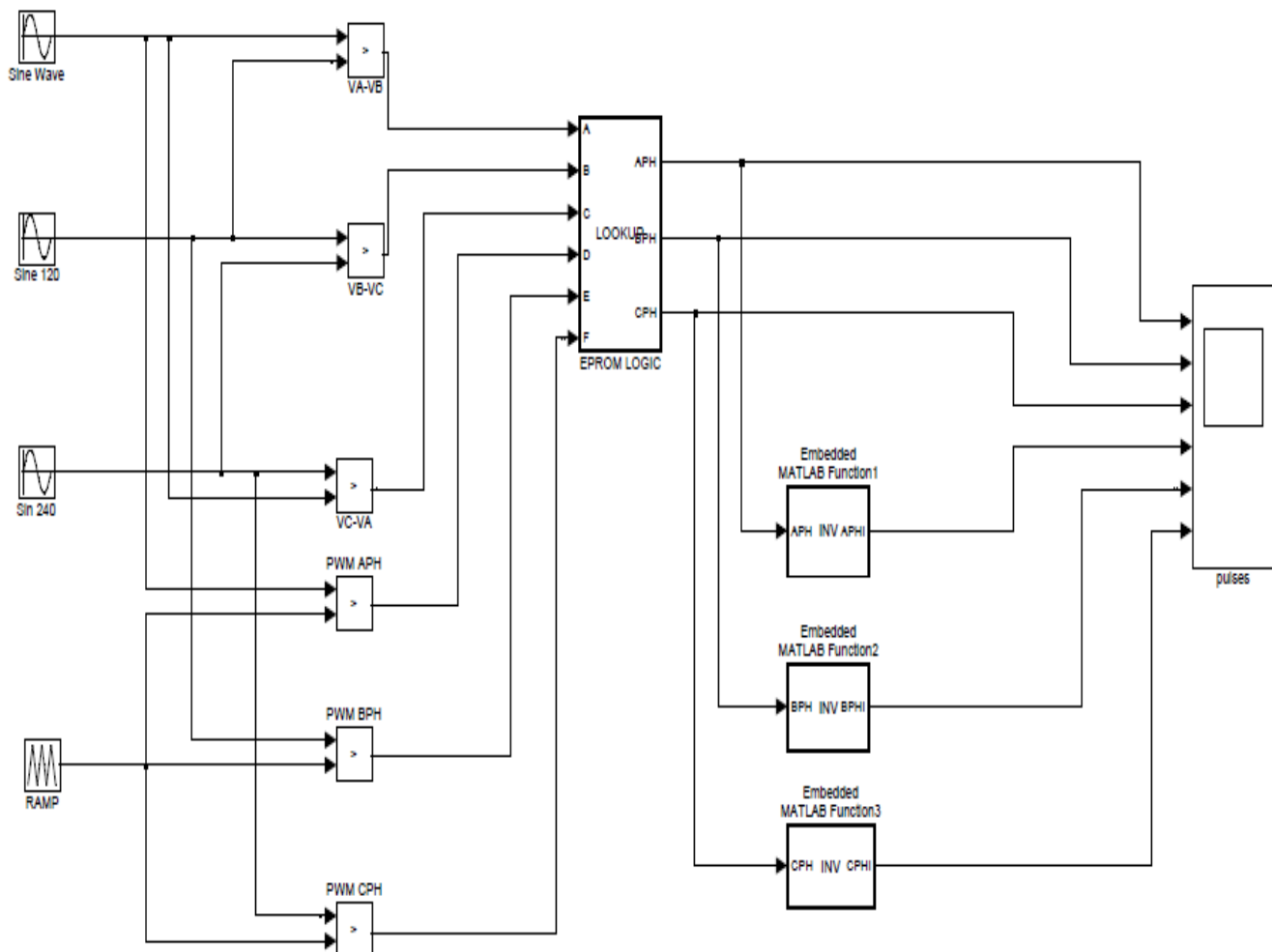

Fig 3.1 PWM generation logic simulation circuit

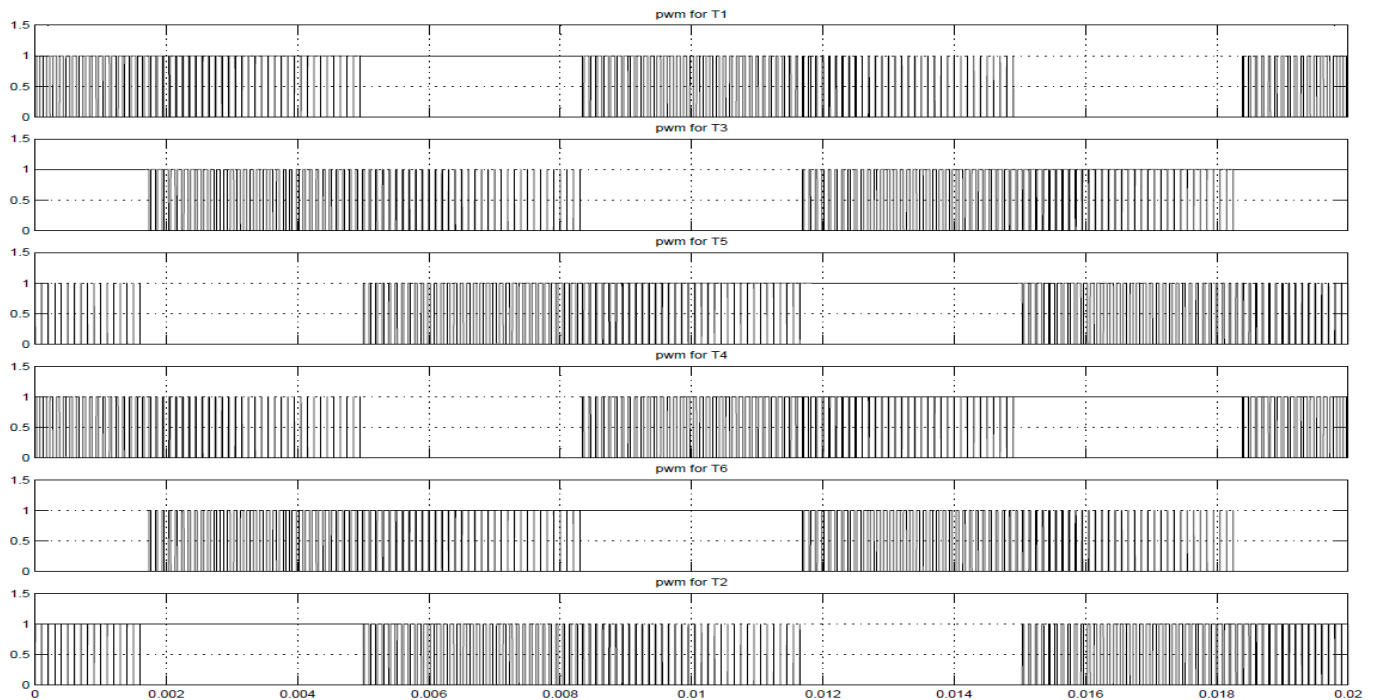

Fig 3.2 Simulated output pulses from pwm generation logic

3.2 SIMULINK MODEL OF PROPOSED SCHEME AND RESULTS

A BLDC motors have 3 phase stator windings , a permanent magnet (PM) rotor. **Fig.3.3** shows a transient equivalent circuit of the BLDCM. The common “y or star” connected stationary stator windings , a balanced 3 three phase system and an air gap which is uniform are assumed here while simulating & modeling . Also while designing the model mutual inductances of 3 stator windings are neglected as they are very small in comparison with self inductance's of respective phases.

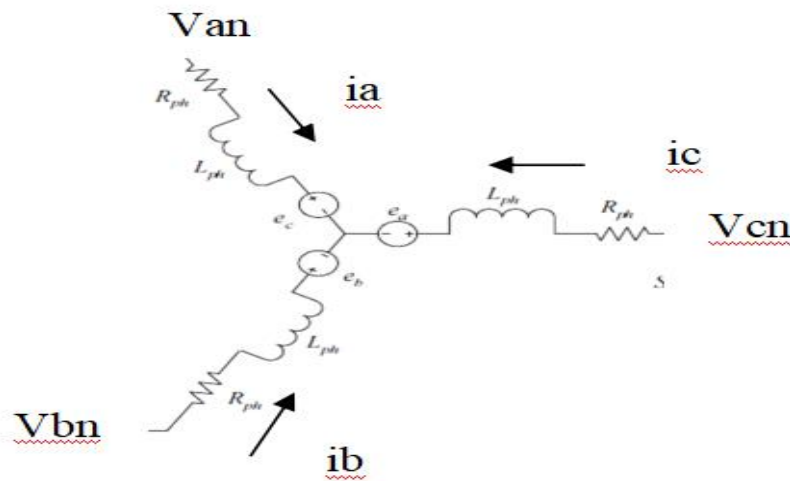

Fig.3.3 Equivalent circuit of BLDCM

From above equivalent circuit model , the 3 phase stator voltage equations of the BLDC Motor is written as given below :-

Stator phase voltages are given by ,

$$\begin{aligned} V_{an} &= i_a R_a + L \frac{di_a}{dt} + E_{b1} \\ V_{bn} &= i_b R_b + L \frac{di_b}{dt} + E_{b2} \\ V_{cn} &= i_c R_c + L \frac{di_c}{dt} + E_{b3} \end{aligned}$$

From which $T_e = P/W_r$

From the dynamic equation for rotation of the motor,

$$\begin{aligned} T_e &= J \frac{dW_m}{dt} + B W_m + T_L \\ \text{But } W_r &= W_m * (P/2) \end{aligned}$$

Back EMFs as in a trapezoidally wound BLDC motor is considered and can be written as

$$E_{b1} = \begin{cases} \frac{E_m}{\pi/6} \theta & 0 < \theta < \pi/6 \\ E_m & \pi/6 < \theta \leq 5\pi/6 \\ \frac{-E_m}{\pi/6} & 5\pi/6 < \theta \leq 7\pi/6 \\ -E_m & 7\pi/6 < \theta \leq 11\pi/6 \\ \frac{E_m}{\pi/6} & 11\pi/6 < \theta \leq 2\pi \end{cases}$$

$$E_{b2} = \begin{cases} -E_m & 0 < \theta < 3\pi/6 \\ \frac{E_m}{\pi/6} & 3\pi/6 < \theta \leq 5\pi/6 \\ E_m & 5\pi/6 < \theta \leq 9\pi/6 \\ \frac{-E_m}{\pi/6} & 9\pi/6 < \theta \leq 11\pi/6 \\ -E_m & 11\pi/6 < \theta \leq 2\pi \end{cases}$$

$$E_{b3} = \begin{cases} E_m & 0 < \theta < \pi/6 \\ \frac{-E_m}{\pi/6} (\theta - 2\pi/6) & \pi/6 < \theta \leq 3\pi/6 \\ -E_m & 3\pi/6 < \theta \leq 7\pi/6 \\ \frac{E_m}{\pi/6} (\theta - 8\pi/6) & 7\pi/6 < \theta \leq 9\pi/6 \\ E_m & 9\pi/6 < \theta \leq 2\pi \end{cases}$$

Where E_m is the maximum magnitude back emf written as,

$E_m = k_e \omega_r$ Where k_e is the back emf constant. From which the stator Phase currents can be found as,

$i_a(s) = (V_{an} - E_a) / (R + sL)$,

$i_b(s) = (V_{bn} - E_b) / (R + sL)$,

$i_c(s) = (V_{cn} - E_c) / (R + sL)$,

Total power developed is given by,

$P = E_a i_a + E_b i_b + E_c i_c = W_r T_e$

ie $T_e = (2/p) * J * (dW_r/dt) + (2/p) B * W_r + T_L$

$T_e - T_L - (2/p) B * W_r = (2/p) * J * (dW_r/dt)$

we know,

$d(\theta)/dt = W_r$

So rotor displacement is

$\theta = (1/S) * W_r$

Motor Specifications Used

55V, 37A, 3 PHASE, 1.5KW

No: of poles, P=10,

Motor torque constant, $K_t = 0.037 \text{ Kg f.m/A}$,

Resistance per phase, $R = 0.5 \text{ ohms}$,

Inductance per phase, $L = 9e-3 \text{ H}$,

Moment of inertia, $J = 0.2156 \text{ Kg m}^2$

Friction constant, $B = 0.200 \text{ N/rad/s}$

Back emf constant, $K_b = 0.600 \text{ v/rad/sec}$

Load torque, $T_L = 0.2 \text{ Newton}$.

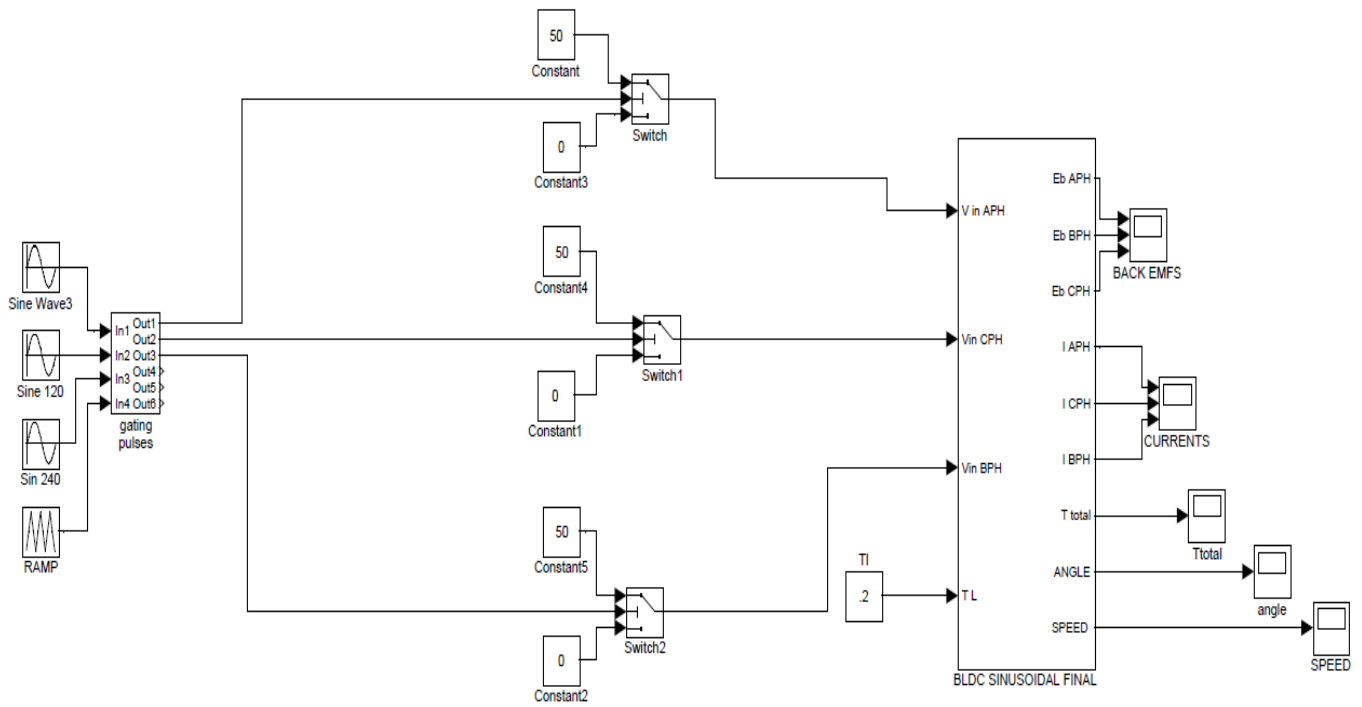

Fig 3.4 Complete simulation circuit

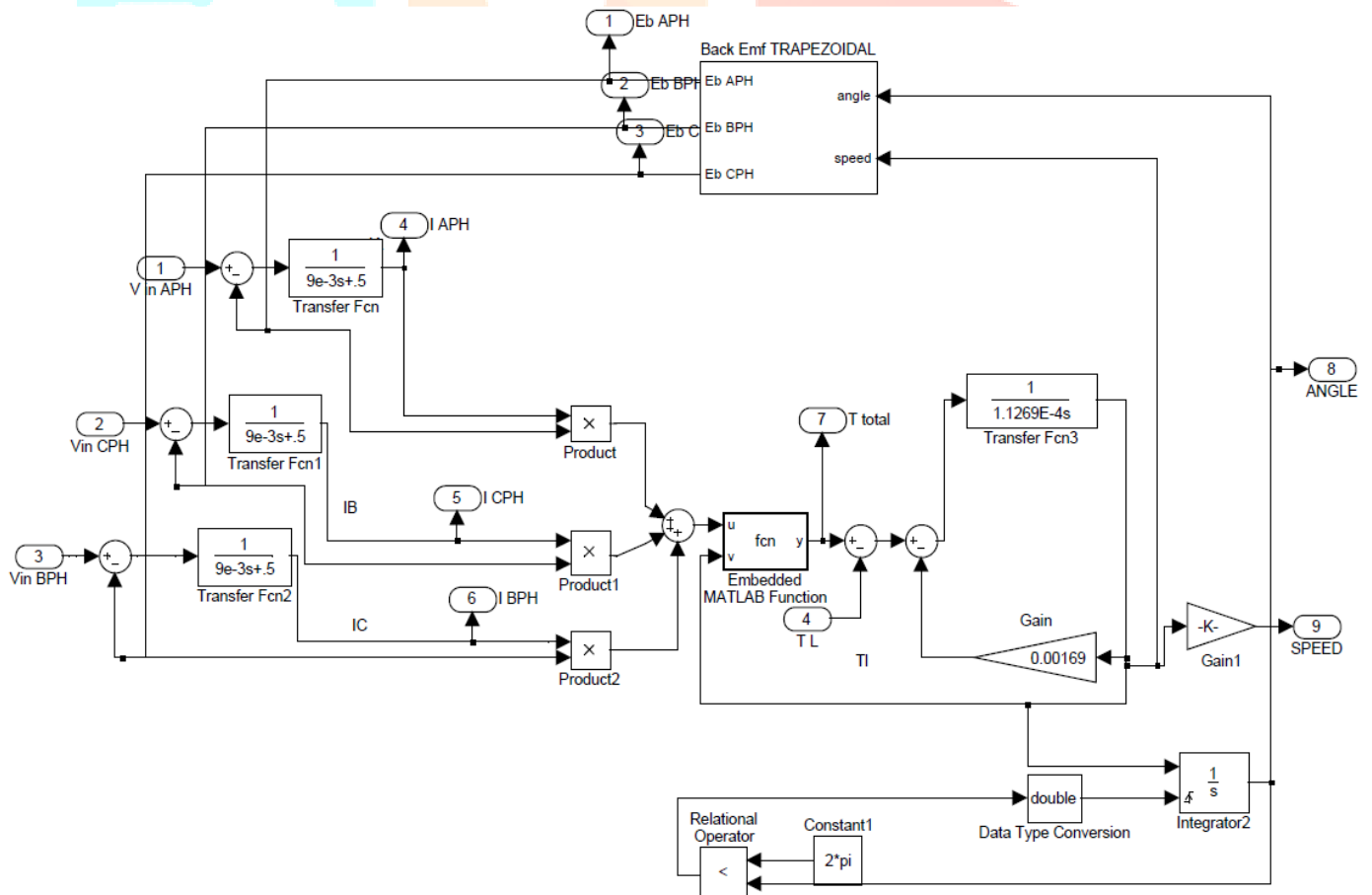

Fig 3.5 BLDC motor simulink model used

As the BLDC motor used is having trapezoidally wound stator windings, the motor model used for simulation was designed to have trapezoidal back EMFs. But even then since sinusoidal commutation technique is being employed the stator phase currents should be as sinusoidal as possible which is the requirement of sinusoidal commutation .

The waveform results from MATLAB SIMULINK showing the variation of important parameters of motor which are rotor speed ω_r , output torque T_e , rotor angle ANG , stator phase currents with respect to time in graph are as given below :-

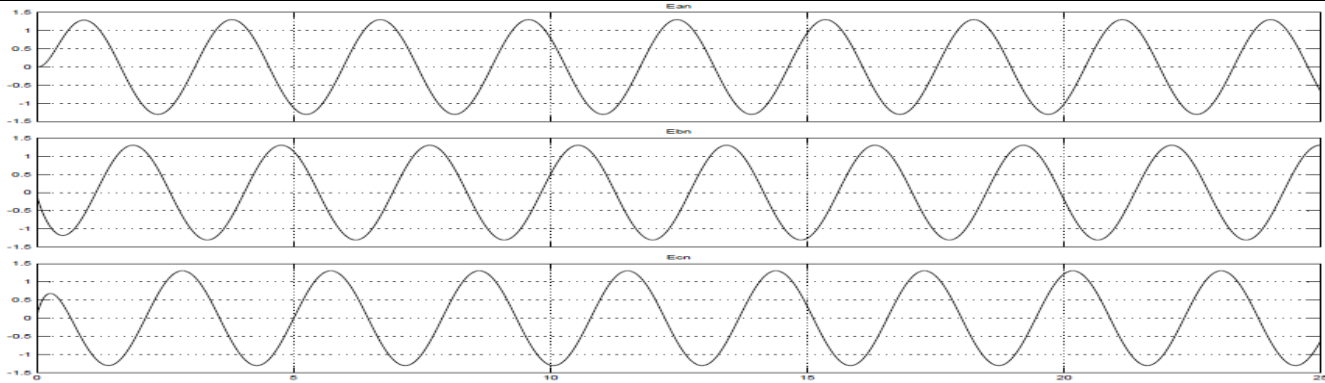

Fig. 3.6 Simulation results for stator phase current waveforms (ia,ib,ic v/s time)

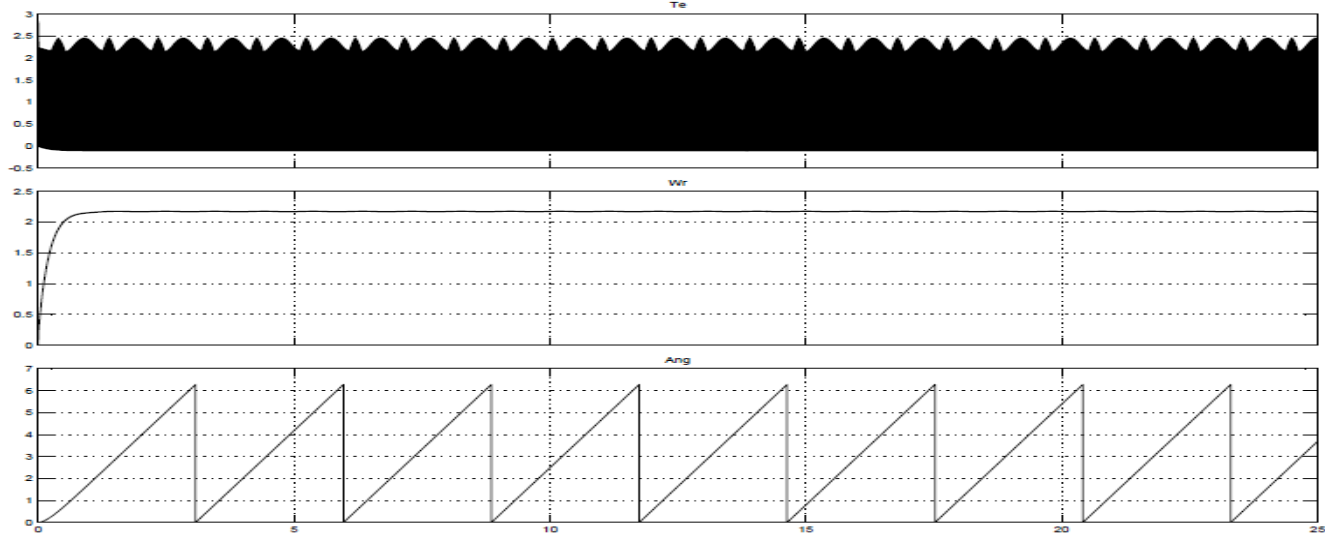

Fig. 3.7 Simulated results for waveforms torque, rotor speed and rotor position (Te ,Wr , ANG v/s time)

From the simulated output waveform the stator phase currents are found to be sinusoidal and not trapezoidal current waveforms (or 6 pulse commutation waveforms) as sinusoidal commutation is being used here. Also its obvious that the ripple torque T_e . Also it can be seen that the angular position Ang varies from 0 to 6.28 radians (0 to 2π) corresponding to 0° to 360° . On reaching 6.28 its being reset to 0 in BLDC model content is greatly reduced in the developed

IV. SUMMARY

The conventional simple trapezoidal commutation (6 pulse commutation)is inadequate to provide smooth & precise control of BLDC motor. In trapezoidal commutation system having a position resolution of 60 deg with hall sensors ,the magnetic fields will continue to vary with lead angle between 60 deg and 120 deg. Thus , the available torque in trapezoidal commutation is only 87 percent. Trapezoidal commutation also causes audible “click” and makes the motor difficult to control with precision at low speeds. The precise measurement of the rotor position is required by control logic to generate PWM signals for inverter stage and continuously vary current signals to fully optimize the conversion of current in to ripple free shaft torque . Here a sinusoidal drive system using Low Cost Hall Effect Sensor ICs in conjugation with an improved PWM pulse generation logic has been suggested and was simulated using MATLAB SIMULINK. The simulation test results indicates that the system performance improves when the sinusoidal drive is employed.

V.CONCLUSIONS

Based on the suggested method and simulation results, the following conclusions are arrived at

- It is found that sinusoidal commutation drive proposed utilizing linear hall effect sensor ensures big reduction in static torque ripple content generated by motor (for the user torque command) which vary based upon the shafts position when compared to trapezoidal commutation.

The proposed PWM pulse generation logic proposed provided gating pulses to the Mosfets in the inverter bridge so as to produce reliable three phase sinusoidal output voltages to drive the BLDC motor drive system .

REFERENCE :

- [1] Lihua Li,member,IEEE , Taoto Jin and Keyue Ma Smedley, Fellow, IEEE : "A NEW ANALOG CONTROLLER FOR 3 PHASE VOLTAGE GENERATION INVERTER " , IEEE transactions on Industrial Electronics , VOL. 15 , NO .1, August 2008 , pp 2894 -2902 .
- [2] F. Caricchi , F. Guilli Capponi, F. Crescimbin ,L. Solero , " SINUSOIDAL BRUSHLESS DRIVE with LOW - COST LINEAR HALL EFFECT POSITION SENSORS " , 0-7803-7067-8/01/\$ 10.00 @ 2001 IEEE , pp 799-804
- [3] C.Gencer ,Dept of Electrical Education & M.Gedikpinar ,Dept of Electronic and computer Education , Firat University ,Elazig ,23100, Turkey , "Modeling & simulation of BLDC Motor using MATLAB/SIMULINK" Journal of Appliances sciences 6 (3) : 688-691,2006 ISSN 1812-5654
- [4]sinewavecommutation,URL:WWW.teknic.com/systems/sinewave-commutation.php
- [5]P C K Luk , C K Lee " Efficient Modelling for a BLDC Motor Drive School of Electronic & Electrical Engineering, The Robert Gordon University, School hill, Aberdeen AB9 IFR, United Kingdom
- [6] AN2372 Application note (signetics) "Low cost sinusoidal control of BLDC motors with Hall sensors using ST7FMC"
- [7] Somanatham, R.; Prasad, P.V.N.; Rajkumar, A.D. "Simulation of PMSBLDC Motor With Sinusoidal Excitation Using Trapezoidal Control Strategy", Industrial Electronics and Applications, 2006 1ST IEEE Conference on Volume , Issue , 24-26 May 2006 Page(s):1 – 6
- [8]Ozturk, S.B. Toliyat , H.A. Texas A&M Univ., College Station;"Direct Torque Control of Brushless DC Motor with Non-sinusoidal Back-EMF", Electric Machines & Drives Conference, 2007. IEMDC '07. IEEE International Publication Date: 3-5 May 2007 Volume: 1, On page(s): 165-170

