



## DESIGN AND DEVELOPMENT OF ADVANCED ROBOTIC LAWN MOVER

<sup>1</sup>NaveenKumar K, <sup>2</sup>Manoji P <sup>3</sup>Manoj Kumar T, <sup>4</sup>Dinesh R, <sup>5</sup> Ravi Prasad S

<sup>1</sup>Assistant Professor, <sup>2</sup>Student, <sup>3</sup>Student, <sup>4</sup>Student, <sup>5</sup>Student

<sup>1</sup>Department of Mechanical and Automation Engineering,

<sup>1</sup>SNS College of Technology, Coimbatore, India

**Abstract:** Gardening has become much more important to keep our infrastructure neat and clean, almost all the house, building, ground, entertainment zones, sports stadiums, etc., has lawn to be maintained properly. It requires very huge human effort to cut the grass and maintain the lawn properly with conventional grass cutters, this project throws light on an automatic lawn cutter helps the user to cut the grass in their lawn with less effort. The different sensors are used to detect and avoid objects obstacles and human intervention while moving. The objective of automatic lawn cutter is that the user can specify the area that is to be cut down with a machine and the height of grass to be cut as per the requirement is done by using the keypad. The design of automatic lawn cutter is done by using an AT mega microcontroller, RF module, IR sensors, motors, LCD Display and Keypad.

**Index Terms-** Automatic Lawn Cutter, IR Sensors, Microcontroller, RF Module, Robot

### I. INTRODUCTION

Pollution is a major threat for entire world because of increasing demand in automobile sector. Pollution starts from our own homes and it was generated by us. The conventional lawn cutter is power by gas which pollutes the environment. Since the cost of fuel usage is increasing day by day it is not an efficient method to go with gas powered lawn cutter. Hence the Solar powered lawn cutters were introduced for eliminating the occurrence of pollution. Solar energy is utilized to power an electric motor for rotation of a blade which in turn cuts the grass in the lawn. But the design cost increases. So an automatic lawn cutter was proposed which consist of a rechargeable battery. To the eliminate the environmental hazardless which has occurred in Hydrogen gas powered lawn cutter, we here propose an alternative solution with automatic lawn cutting machine. The lawn cutter with the revolving blades helps to cut the lawn at even long length to make it good looking. In the existing model of the grass cutter, IC engines were employed to rotate the blade which brings an environmental impact of pollution level. The consumption of fuels and the emission of the fuels causes environmental hazardous. Nowadays, pollution is a main crisis in the worldwide issue, which is human intervention and will be proved in many places. In case Gas powered lawn mowers if employed which also exhibits emission of gases leads environmental pollution. The cost of the fuel is very high which will not provide the users to achieve the efficient in lawn maintenance. The maintenance of such a conventional engine is too difficult and tedious to handle for the human, to avoid these drawbacks, an idea is proposed to rectify the drawbacks with innovative concept and design.

The lawn cutter with the revolving blades helps to cut the lawn at even long length to make it good looking. In the existing model of the grass cutter, IC engines were employed to rotate the blade which brings an environmental impact of pollution level. The consumption of fuels and the emission of the fuels causes environmental hazardous. Nowadays, pollution is a main crisis in the worldwide issue, which is human intervention and will be proved in many places. In case Gas powered lawn mowers if employed which also exhibits emission of gases leads environmental pollution. The cost of the fuel is very high which will not provide the users to achieve the efficient in lawn maintenance. The maintenance of such a conventional engine is too difficult and tedious to handle for the human, to avoid these drawbacks, an idea is proposed to rectify the drawbacks with innovative concept and design.

### II. INSTRUMENTATION AND METHODOLOGY:

#### 2.1 Ultrasonic Sensors

Ultrasonic sensors (also known as transceivers when they both send and receive) work on a principle similar to radar which evaluate attributes of a target by interpreting the echoes from radio or sound waves respectively. Ultrasonic sensors generate high frequency sound waves and evaluate the echo which is received back by the sensor. Sensors calculate the time interval between sending the signal and receiving the echo to determine the distance to an object. This technology can be used for measuring: wind speed and direction (anemometer), fullness of a tank and speed through the air or water. For measuring speed or direction a device uses multiple detectors and calculates the speed from the relative distances to particulates in the air or the water. To measure the amount of liquid in a tank, the sensor measures the distance to the surface of the fluid. Further applications include: humidifiers, sonar, medical ultra sonic, burglar alarms and non-destructive testing.



Fig.1

## 2.2 Arduino UNO

Arduino is an open-source electronics platform based on easy-to-use hardware and software. Arduino boards are able to read inputs - light on a sensor, a finger on a button, or a Twitter message - and turn it into an output - activating a motor, turning on an LED, publishing something online. In this automated mower robo arduino is as main microcontroller for this robot. The Bluetooth module and ultrasonic sensor is connected to this board on digital and the analog pins. With proper programming on arduino board mower can be used automatically. You can tell your board what to do it by sending a set of instructions to the microcontroller on the board. To do so you are use the Arduino programming language (based on Wiring), and the Arduino Software (IDE), based on Processing.



Fig.2

## 2.3 Motor Driver

The programming will be same for BJT circuit and L293D by allowing the appropriate combinations of A and B. The programming is done by using C language. In making a robot, the first thing is to make move on the ground. Either in DC motor or a stepper motor can be selected for making the movement of robot. Dc motors are preferred in case of consideration of factors such as an speed, weight, size, and cost. Three pins namely as A, B and Enable are needed for interfacing a DC motor. By connecting Enable to VCC, the output can be enabled and to make the motors work only two pins are required. It is easy to program with the microcontroller. The programming will be same for BJT circuit and L293D by allowing the appropriate combinations of A and B. The programming is done by using C language.

## 2.4 DC Motor

A DC motor relies on the fact that like magnet poles repel and unlike other magnetic poles attract each other. A coil of wire with a current running through it generates a electromagnetic field aligned with the center of the coil. By switching the current on a or off in a coil its magnetic field can be switched on or off or by switching the direction of the current in the coil the direction of the generated magnetic field can be switched 180°. A simple DC motor typically has an stationary set of magnets in the stator and an armature with a series of two or more windings of wire wrapped in insulated stack slots around iron pole pieces (called stack teeth) with the ends of the wires terminating on a commutator.



Fig.3

## 2.5 Servo Motor

A servomotor is an linear actuator or rotary actuator that allows all precise control of linear or angular position, acceleration, and velocity. It consists of a motor coupled to a sensor for position feedback. It also required an relatively sophisticated controller, often a dedicated module designed as specifically for use with servomotors.

III. CIRCUIT DIAGRAM

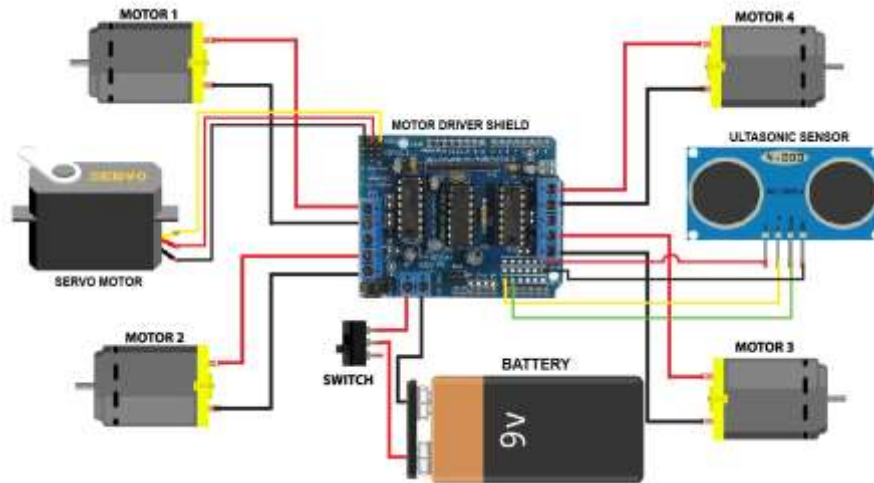

Fig.4

IV. WORKING:

The design contains an microcontroller, ultrasonic sensor, DC motor, Arduino UNO all these together combined we get a grass cutter robot. I used only an ultrasonic sensor to detect if the robot was heading into an object. Safety is the main concern when designing a robot with blades. Determining where to place our sensors is a crucial to the overall effectiveness of our design. The microprocessor must be in the robot to protect it from the natural elements and object. Ultrasonic sensor will be mounted directly in front of the robot for maximum detection. Batteries are uses for power generation for the robot movement and the battery is a rechargeable. Arduino is used as a programmable model to connect the system to its driver.

V. CONTROL PROCESS:

After the start-up of the power supply, the robotic lawn mower needs to wait for the connection between the Arduino UNO and the human-machine interface, then the human machine interface sends the communication packet, when the success of the communication was confirmed, modes could be chosen. Both side lengths of the rectangle were input after the blade had started for a few seconds. The crawler tracks and lawn mower operated and cooperated with the choice of the mode to complete the instruction. After the motor started, the PIR sensor module continuously detected for a warm body. If a warm body was detected within 2.4 m of the straight line, then all motors stopped action, the mode would need to be re-selected. Different from automatic lawn mowers on the market, our design placed the mowing cutter head in front of the crawler tracks, which stressed the swinging personification to the left and right, and used the bearing support frame as the human body, the steering device as the human waist, the slide platform device as the human hands, and the synchronization with the motor control and the sensor cost.

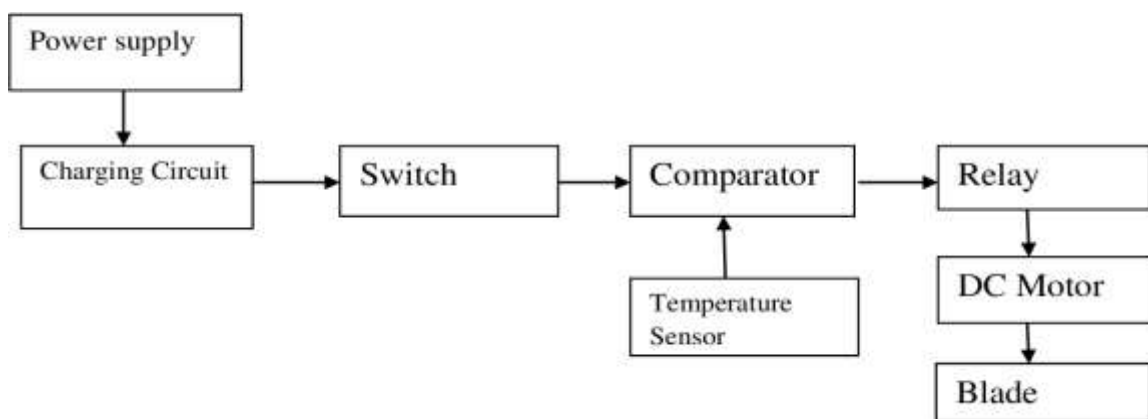

Arduino Board, Bluetooth module and other electrical components were used in circuit. Three DC motors were used two for rear wheels and one for the blades. The front wheels located below the main body were used for rotating rubber tires , gives information about Autonomous Grass Cutting robot which was Solar Powered. The system contains components like IR Proximity sensor, DC motor. The use of microcontroller makes the system cheap and implementation becomes easy. This light weight portable machine is also provided remote control system to work as automatically as well as manually. Another feature of

this system is not necessary to give instruction to move the robot manually, it automatically move by using green grass sensor and cut the existing grass. To perform in unknown environment system uses "sense act approach". This system was implemented using a Motor Schema source that encoded responses continuously for coordinating behavior of the system. Couple sensor is used for identifying mown or unmown grass. In this behavior-based lawn mower, author proposed the design of this system to complete the given task in a dynamic and unstructured environment, which is basically unknown for the robot. To overcome the problems of moving obstacles, cameras can be used for obstacle detection.

## VI. CONCLUSION:

The smart lawn mower is an automated with all the inputs from sensor and the mowers can mow the garden are field all by itself without any human can take interaction and send the details to web server and lets the user communicate with the smart lawn mower with android application. An Automatic lawn cutting machine was developed for the use of cutting grass in residential area and is established as an alternative replacement in place of tractor driven grass cutting machines. This machine provides good replacement for the gasoline powered of lawn mowers also. Thus, Automatic Lawn Cutter was developed by using Arduino UNO, Motor Driver, RF module, IR sensors, motors and battery and was made to automatically work successfully. The smart lawn cutter is designed and fabricated with innovative methodology to achieve the lawn trimming in an even shape. The fabricated machine is successfully integrated with a programming is connected to the smart to perform various actions of lawn mower. The communication was developed between Arduino UNO and the android application using Bluetooth module to functionalize the smart mower in efficient way.

## VII. REFERENCES:

- [1] <https://www.einhell.fr/shop/en-fr/freelexo-1200-lcd-bt.html> Design and Development of Grass Cutter in an Advanced module.
- [2] Yan-Fang Li, Saul Harari, Hong Wong, and Vikram Kapila (2004, July). Matlab-Based Graphical User Interface Development for Basic Stamp 2 Microcontroller Projects. Proceeding of the 2004 American Control conference, 3233-3236. Retrieved on May 6, 2009 from IEEExplore .
- [3] Gomathy SS, Saravanan S, Thangavel S. Design and implementation of maximum power point tracking (MPPT) algorithm.
- [4] Jason Smith, Scott Campbell, Jade Morton (July 2005). Design and Implementation of a Control Algorithm for an Autonomous Lawnmower. Department of Electrical and Computer Engineering Miami University. 456-459. Retrieved on May 6, 2009 from IEEExplore.
- [5] Haydar Sahin and Levent Guvenc (April 2007). Household Robotics Autonomous Devices for Vacuuming and Lawn Mowing. IEEE Control Systems Magazine. 20-24. Retrieved on May 6,2009 from IEEExplore
- [6] Chiara Fiori, KyoungHo Ahn, Hesham A. Rakha, Power-based electric vehicle energy consumption model: Model development and validation, Applied Energy, Volume 168, 15 April 2016, Pages 257-268.