



INTERNATIONAL JOURNAL OF CREATIVE RESEARCH THOUGHTS (IJCRT)

An International Open Access, Peer-reviewed, Refereed Journal

LOW COST AUTOMATED SWITCH

¹NaveenKumar K, ²Srinivasan. P, ³Gowri Prasad. S, ⁴Arjun. M, ⁵Prem Kumar. R

¹Assistant Professor, ²Student, ³Student, ⁴Student, ⁵Student

¹Department of Mechanical and Automation Engineering,

¹SNS College of Technology, Coimbatore, India

Abstract: Our recent future needs an innovative way to control all the electrical and electronic appliances in office and in home. In this paper we proposed a solution which will be very useful in achieving this. The control of these electrical and electronic appliances is achieved by the use of a single microcontroller. It has a microcontroller as the root memory and many RF transmitters which will help to control many home appliances. It can be controlled via manual switch, android application, and voice assistant. The android application shows the status of the switch whether the switch is active or not. The application ensures that the power is managed efficiently by indicating to the user, the connections that are turned on unnecessarily. This helps out in reducing the cost, saves energy and also helps to monitor.

Index Terms - Keywords: Appliances, switch, microcontroller, energy, power.

I. INTRODUCTION

The pandemic of COVID has changed our life style. To adopt to these new changes, our homes and offices will have to be re-designed to prevent from the virus. Today every home and office have many electrical and electronic appliances, more people are redesigning their homes and office to automation system. By automating our home and offices, remotely monitor, we can save electricity and control our appliances. When we are at vacation or out from home; the smart home automation system will alert us if we have forgotten to switch off anything, and we can remotely control them through the smartphone. Automating home and office cost high and want to change some circuit connection, but our project makes it easy to install in office and home. We tried hard to reduce the cost of the final product.

II. DESIGN

2.1 ESP-12E WI-FI module

ESP-12E is a Wi-Fi module present in the today's market and is used for wireless network connection for microcontroller. The core of ESP-12E is ESP8266EX. The module is built in microcontroller. It has a Wi-Fi feature that can be connect via IoT to control through internet. It is a low-cost solution for developing IoT applications.



Fig.1

2.2 HI-LINK 5V AC-DC convertor

HLK-PM01 5V/3W Switch Power Supply Module is step-down power supply module as our project requires 5V power supply to power the circuits. It can supply 5V DC from 120V AC – 230V AC. It has a power rating of 3 Watt. This Power Supply Module voltage source is a switching source, so fluctuations in voltage grid can be minimized. It is designed to be mounted on the PCB.

2.3 SPDT Relay

Relays work on electromagnetism, When the Relay coil is energized it acts like a magnet and changes the position of a switch. The circuit which powers the coil is completely isolated from the part which switches ON/OFF, This provides electrical isolation. The other end of it could be running a 220 to 240V appliance, the 240V end is completely isolated from the 5V Arduino circuitry.

2.4 AMS1117 SOT-223

The AMS1117 is a 3-pin voltage regulator that is available in many fixed and adjustable voltage requirements. The IC can deliver a maximum current of 1A and the output voltage can vary from 1.5V to 5V. It also has a low drop out voltage of 1.3V when operating at maximum current.

2.5 BC547 NPN Transistor (as switch)

When a transistor is used as a switch it is operated in the Saturation and Cut-Off Region. A transistor will act as an Open switch during Forward Bias and as a closed switch during Reverse Bias, this biasing can be achieved by supplying the required amount of current to the base pin.

2.6 FTDI module

The FTDI USB to TTL serial converter module is a UART (universal asynchronous receiver-transmitter) board used for TTL serial communication. It is used to feed code into ESP-12E module.

III. SOFTWARE

3.1. ARDUINO

The open-source Arduino Software (IDE) makes it easy to write code and upload it to the Arduino board.

3.2 BLYNK

Blynk is a Platform with Android apps to control Arduino over the Internet.

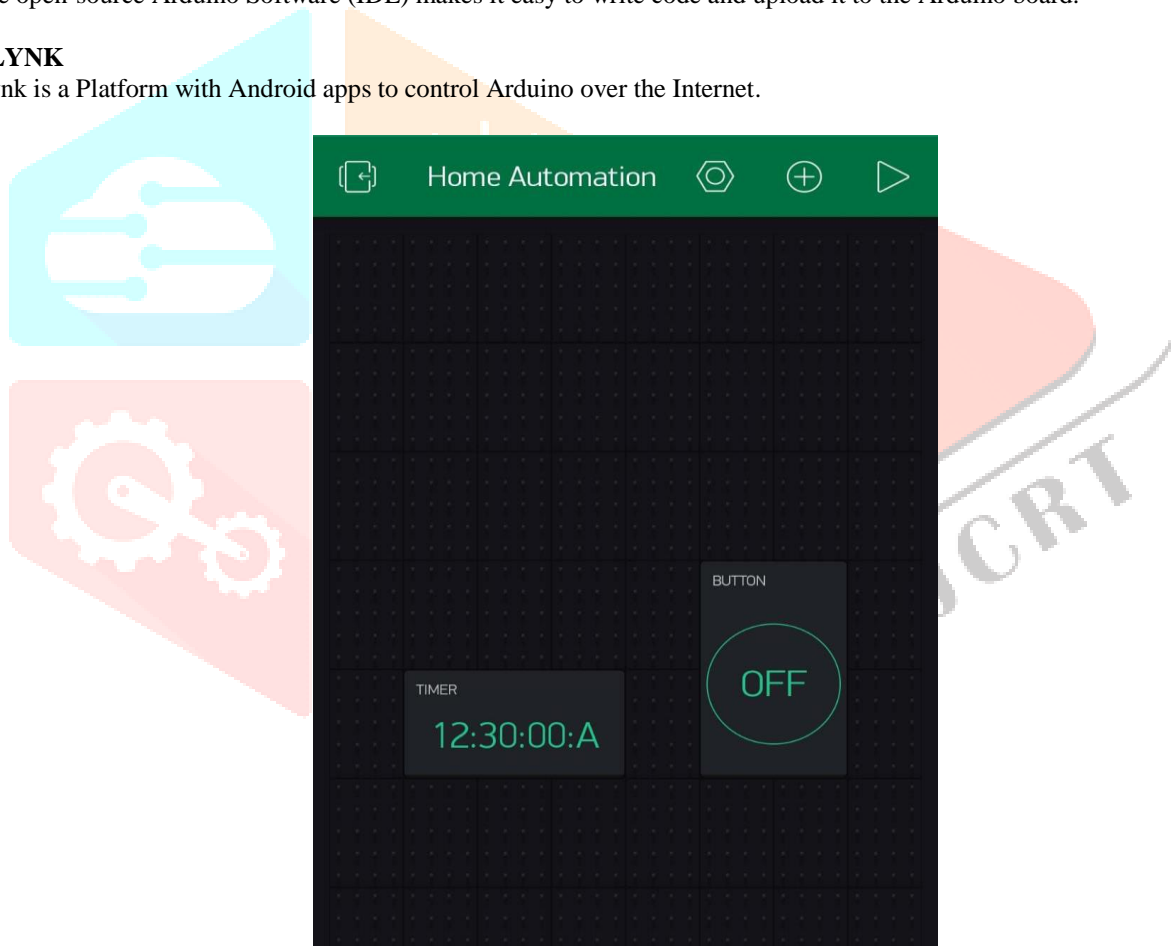

Fig.2

3.3 IFTTT with Google Assistant

It is used to create custom voice commands for Google Assistant to control via voice assistant. The google assistant is triggered using blynk token.

IV. CIRCUIT CONNECRION

4.1 CIRCUIT DIAGRAM

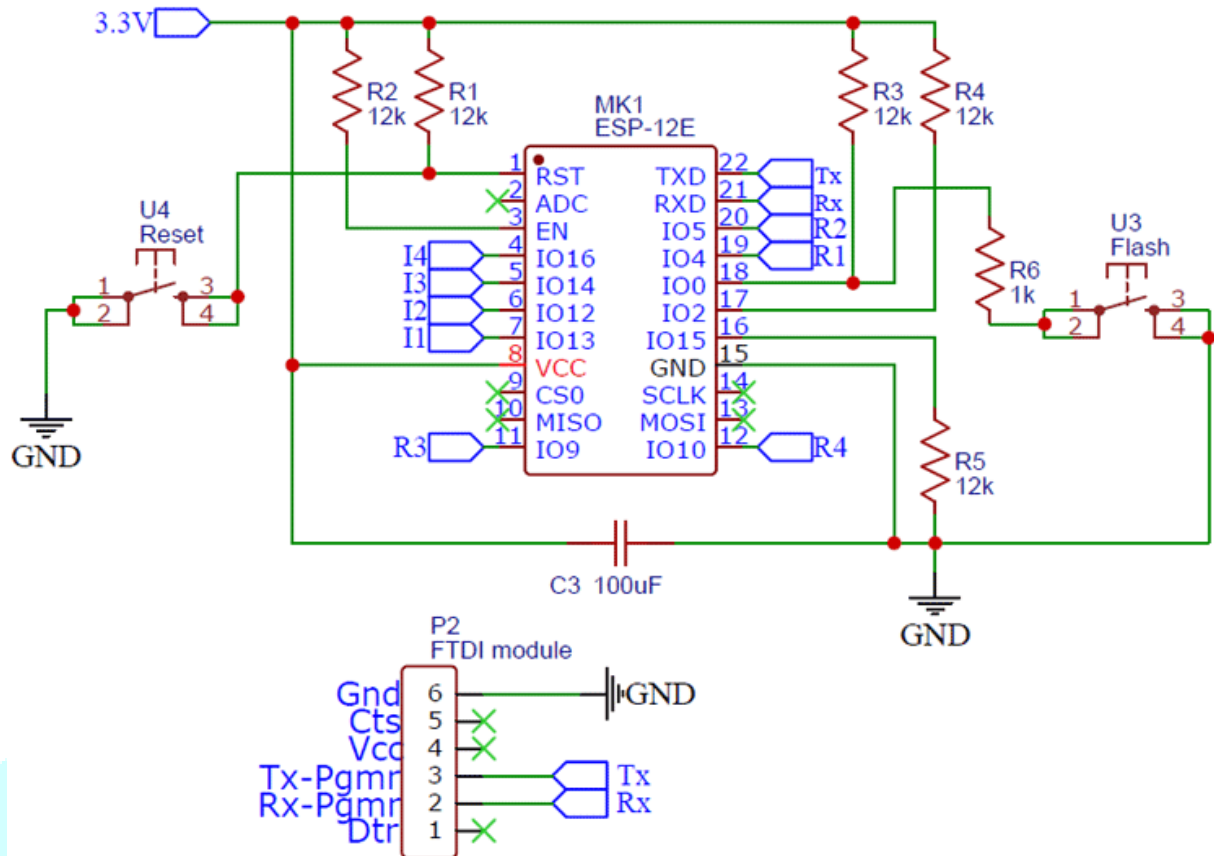

Fig.3

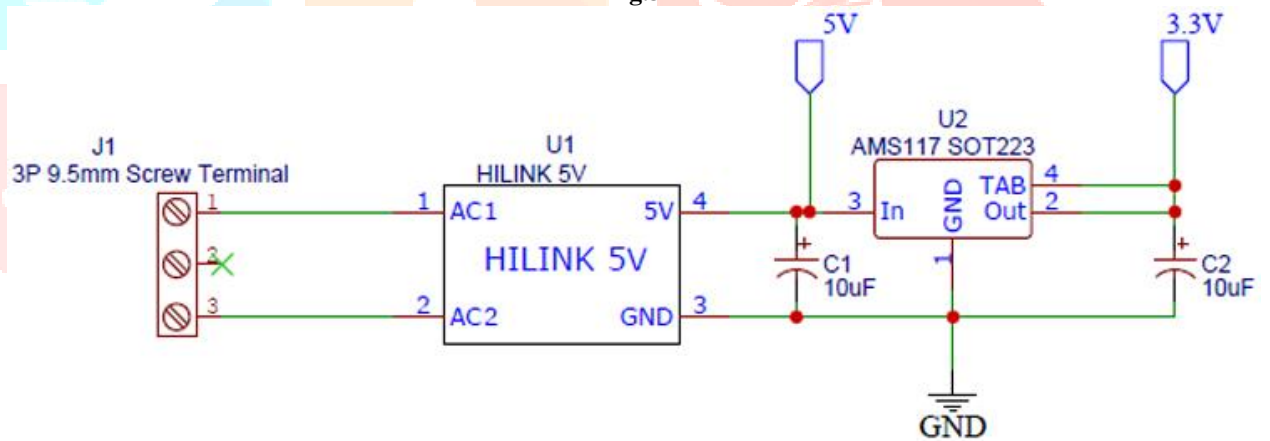

Fig.4

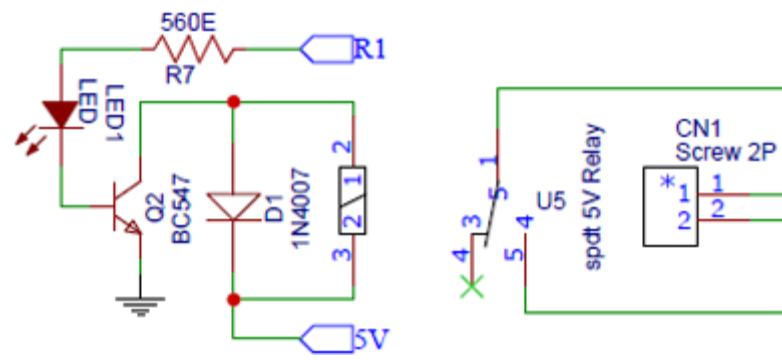

Fig.5

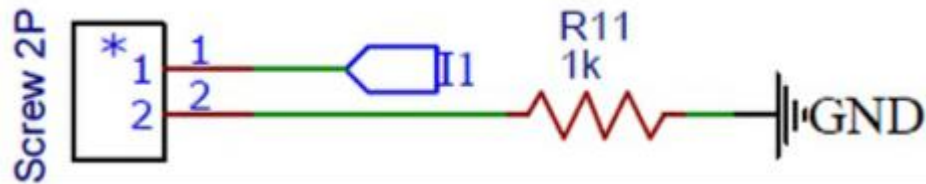

Fig.6

4.2 FTDI MODULE CONNECTION

The FTDI module is first connected to ESP-12E module and code is feed into the module using Arduino IDE. Then the connection of FTDI module is removed. Hence it is used only to feed the code into module.

4.3 SYSTEM FLOW

When the circuit is powered the ESP-12E module is boot into normal mode. When the switch is on the circuit works normally. When the switch is triggered via voice assistant or by application the switch works alternatively as two-way switch.

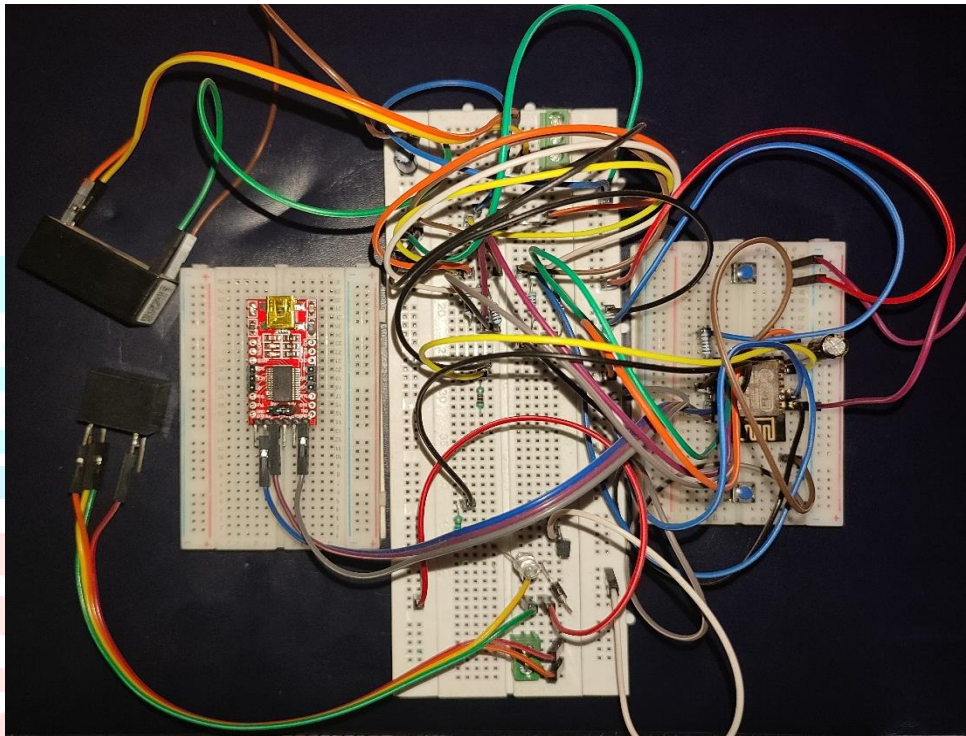

Fig. 7

V. CONCLUSION

The working model of “**LOW COST AUTOMATED SWITCH**” has been completed successfully. The idea behind automatic switching is that the automatic switches present in the market is only control via mobile applications or voice assistant. We planned to control manually also control through voice assistant and mobile application. Thus, automatic switching can be performed as frequently as needed in contrast with manual switching. Furthermore, an automatic switch can quickly isolate faulted sections of the network to minimize power interruption. The time required for these switching operations may take few seconds due to computer control and remote communications. The greatest benefit of the automated approach is that the need for a new substation and all of its associated costs are eliminated until future loads are much larger. Since it low cost even middle class people can afford this product.

REFERENCES

1. https://www.researchgate.net/publication/323757690_DESIGN_AND_DEVELOPMENT_OF_SMART_BRANCHED_SWITCHES_FOR_HOME_AUTOMATION
2. Alheraish, “Design and Implementation of Home Automation System”, 2004, IEEE Transactions on Consumer Electronics, Vol. 50(4) , pp. 1087-1092.
3. Inderpreet Kaur, “Microcontroller Based Home Automation System With Security” at IJACSA) International Journal of Advanced Computer Science and Applications, Vol. 1, No. 6, December 2010
4. Ahmed ElShafee, Karim Alaa Hamed “Design and Implementation of a WiFi Based Home Automation System” Vol:6 2012
5. Bourdillon.O.Omijeh Reminus.O. Okeke “Design Analysis of a GSM/RF-Based Remote Controlled Robotic Car”, Vol.6, No.1, 2015