



## HARDWARE IMPLEMENTATION OF DESIGN MODEL FOR BATTERY BALANCING SYSTEM USING SOLAR POWER FOR ELECTRIC VEHICLES

<sup>1</sup> A. B. Akhade, <sup>2</sup> A. P. Kinge

<sup>1</sup>PG Student, <sup>2</sup>Assistant Professor

<sup>1</sup>Department of Electrical

<sup>1</sup>TSSM's BSCOER, Narhe, Pune, India

**Abstract:** In this paper hardware of design model for battery balancing system using solar power for electric vehicles is proposed. The hardware system is composed of solar panel, microcontroller arduino mega 2560, INA219 current sensor, relay, battery, glcd, dc series motor, ULN 2003 driver, etc. The hardware is designed to balance battery by using three modes namely solar, storage and charge balancing mode. These three modes are selected by connecting relay operated by arduino through ULN 2003 relay driver. The INA 219 sensor measures voltage and current values. The hardware results are shown on the graphics lcd for the three modes.

**Index Terms -** Arduino, Relay, Battery, ULN 2003 driver.

### I. INTRODUCTION

Battery systems as a vital part of the electrical vehicles are facing major difficulties, the most important matter is the cells unbalancing. The cells unbalancing leads to individual cell voltages differ over time, decreasing the battery pack capacity that consequently will fail of the total battery system in the long run. In addition, cell equalization acts an important role on the battery life preserving. The electric vehicle (EV) has become increasingly attractive in recent years after the intensive efforts by the governments, automakers and environmental activists. For the applications like plug-in hybrid electric vehicles (PHEVs) and electric vehicles (EVs) the battery cells are connected in series in order to supply higher voltage and higher power to the load. Due to manufacturing caused variations & varying operation conditions the imbalances in battery reduce the usable energy. To solve imbalance issue many researchers made techniques and control algorithms. Battery balancing is the technique that improve the available capacity of a battery pack with multiple cells and increase each cell life. Cell balancing is the process of equalizing the voltages and state of charge among the cells when they are at a full charge. No two cells are identical. There are always slight differences in the state of charge, self-discharge rate, capacity, impedance, and temperature characteristics.

Because of the upsides of ease and basic control, inactive adjusting is one of the most generally applied plan in battery management system (BMS). The working calculation of uninvolved adjusting is straightforward: when a solitary cell arrives at the charge voltage limit, it will be released by a power resistor, which causes different batteries to can be completely energized. The other methodology, dynamic adjusting circuits balance the battery by moving vitality from cells with high state of-charge (SOC) to cells with lower SOC. There are three active balancing method based on energy transform component: Capacitor based, Inductor based and DC/DC converter based. A few investigates have received a portion of these techniques to battery particular adjusting. In any case, there is practically no measured adjusting applied in creations EVs and particular lopsidedness could prompt more terrible over-charge and over-release harming. This is on the grounds that the battery modules are normally with high vitality, hence the vitality distinction between unbalancing modules is a lot higher than that of cells. For this situation, the adjusting power request, productivity and warmth dissemination will be issues for vitality move parts. Subsequently, a perfect answer for the particular adjusting is to accuse low SOC modules of vitality source out of the battery pack. The dynamic adjusting circuits even out the battery by moving vitality from cells with higher state of charge (SOC) to cells with lower SOC and can be worked during both charge and release forms. Three sorts of cutting edge dynamic adjusting circuits are summed up in capacitive adjusting, inductive adjusting, and blended dynamic adjusting. For capacitive based dynamic adjusting, at least one capacitors are exchanged in corresponding to a cell the vitality move is the aftereffect of voltage contrast between cells. The benefit of capacitive adjusting is no unpredictable control calculation is required. Be that as it may, the adjusting procedure is exceptionally moderate. Moreover, the capacitance opposition brings power misfortune and the adjusting procedure is moderate. The inductive offsetting utilizes transformers with air-gapped attractive centers or inductors to move vitality between cells. Contrasted and capacitive adjusting, the inductive adjusting can accuse a cell of equivalent or higher voltage with another

cell. And yet, the iron misfortune and copper loss of the inductive parts brings influence loss of the battery pack.

In this paper hardware works on three operation modes. (1) When the vehicle is parked and being charged, the solar energy as well as the actively discharged energy from high voltage battery modules will be stored in an independent storage cell. (2) When the vehicle is driving in a sunny day, the solar power is used to charge low voltage or low SOC battery modules, or the whole battery pack when all the modules are balanced. (3) If the solar power is hard to harvest, for example, in cloudy, rainy weather or at night, the battery modules with low voltage will be charged by the storage cell. Because the energy used for the active battery balancing comes from energy source independent of the battery pack, the extra energy loss of the battery pack during balancing can be eliminated.

## II. Hardware Block Diagram

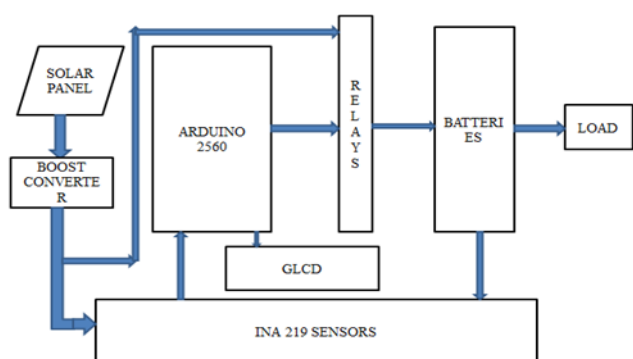

Figure 1: Hardware block diagram

The hardware works on three modes namely solar balancing mode, storage balancing mode, charge balancing mode.

### 1. Solar balancing mode :

When solar power is available then this mode is selected by pressing the P.V. button provided on hardware. Then relay 11 & 12 is connected after that arduino checks and balances batteries by connecting relay (1<sup>st</sup> & 3<sup>rd</sup> relay for first battery, 2<sup>nd</sup> & 5<sup>th</sup> relay for second battery, 4<sup>th</sup> & 6<sup>th</sup> relay for third battery for all modes) .

### 2. Storage balancing mode :

When solar power is unavailable then this mode is selected by pressing the S.B. button provided on hardware. Then relay 9 & 10 is connected after that arduino checks and balances batteries by connecting relay.

### 3. Charge balancing mode :

When electric vehicle is parked and charged by charger then this mode is selected by pressing the Charger button provided on hardware. Then relay 7 & 8 is connected after that arduino checks and balances batteries by connecting relay.

Hardware:

1.Solar panel: 10 W polycrystalline solar plate is used.

2.Arduino: The Arduino Mega 2560 is a microcontroller board based on the ATmega2560 (datasheet).It has 54 digital input/output pins (of which 14 can be used as PWM outputs), 16 analog inputs, 4 UARTs (hardware serial ports), a 16 MHz crystal oscillator, a USB connection, a power jack, an ICSP header, and a reset button. It contains everything needed to support the microcontroller; simply connect it to a computer with a USB cable or power it with a AC to DC adapter or battery to get started. The Mega is compatible with most shields designed for the Arduino Duemilanove or Diecimila.

3.Sensor: The INA219 is current shunt and power monitor with an I<sup>2</sup>C- or SMBUS-compatible interface. The device monitors both shunt voltage drop and bus supply voltage, with programmable conversion times and filtering. A programmable calibration value, combined with an internal multiplier, enables direct readouts of current in amperes. An additional multiplying register calculates power in watts.

**Arduino Software Details:** The programming is done by using Arduino 1.8.7 IDE software. Arduino Software (IDE) - contains a text editor for writing code, a message area, a text console, a toolbar with buttons for common functions and a series of menus. It connects to the Arduino and Genuino hardware to upload programs and communicate with them.

## III. Circuit Layout

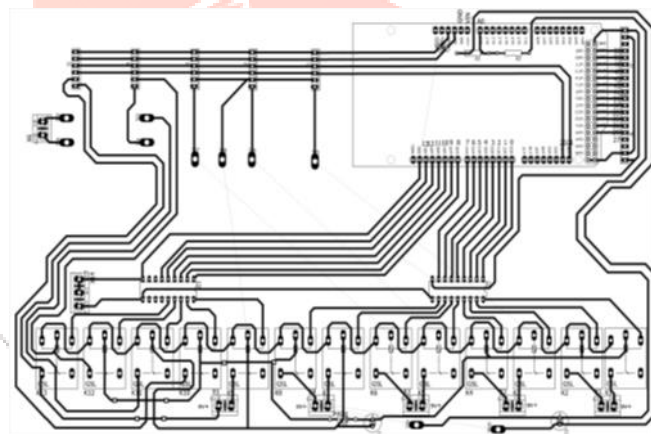

Figure-2 Circuit Layout

The hardware components are connected as per the above circuit layout.. Relays are connected to arduino through uln 2003 driver. First six relays (from right side) are connected to batteries. From relays 7 to 12 are used for mode selection.

#### IV. Hardware Model and Results



Figure-3 Hardware Model

A photograph of the experimental setup constructed at the laboratory is shown in Figure-3

#### Results

For the three modes namely solar, storage, charge results taken at time = 10 sec. in first display and second display shows results taken at time = 20 sec. also it shows difference in voltage in first display. Second display shows battery voltage is balanced. In this result battery, pv, mains supply, storage battery voltage and current are shown below on graph lcd.

##### 1. Solar Balancing Mode



##### 2. Storage Balancing Mode



##### 3. Charge Balancing Mode



#### Conclusion

This paper proposes hardware of design model for battery balancing system for electric vehicles based on solar power harvesting and storage.

1. The system is designed to charge the battery module with the lowest SOC/voltage during discharging using the solar energy.
2. When solar power is unavailable energy is taken from a storage cell to avoid the energy loss that happens in conventional active and passive battery balancing schemes.
3. With the help of charge balancing mode batteries are charged with charger after completion of battery charging then excess charge shift to storage battery for charging.

#### References

1. Chen Duan, Member, IEEE, Caisheng Wang, Senior Member, IEEE, Zongzheng Li, Jianfei Chen, Shidao Wang, Adrian Snyder and Chenguang Jiang - A Solar Power Assisted Battery Balancing System For Electric Vehicles || , in IEEE Transactions on Transportation Electrification 2018.
2. Maurice Caspar, Torsten Eiler, and Soren Hohmann. "Comparison of active battery balancing systems." In Vehicle Power and Propulsion Conference (VPPC), 2014 IEEE, pp. 1-8. IEEE, 2014.
3. Xiaosong Hu, Clara Marina Martinez, and Yalian Yang. "Charging, power management, and battery degradation mitigation in plug-in hybrid electric vehicles: A unified cost-optimal approach." Mechanical Systems and Signal Processing 87 (2016): 4-16.
4. Y. Gao, K.B. Farley, A. Ginart, and Zion Tse. "Safety and efficiency of the wireless charging of electric vehicles." Proceedings of the Institution of Mechanical Engineers, Part D: Journal of Automobile Engineering 230, no. 9 (2016): 1196-1207.
5. L. Liu, LY Wang, Z. Chen, C. Wang, F. Lin and H. Wang, — Integrated System Identification and State-of-Charge Estimation of Battery Systems, || IEEE Transactions on Energy Conversion, vol. 28, no. 1, 2013.
6. Viet T. Tran, Md. Rabiul Islam, Kashem M. Muttaqi, Danny Sutanto, — An Efficient Energy Management Approach for a Solar-Powered EV Battery Charging Facility to Support Distribution Grids, IEEE Transactions on Industry Applications, August 27, 2019.

7. Yeqin Wang and Yixing Liu, — Electronic Control System Design and Test of Pure Electric Vehicle Battery Management System, IEEE 2011.
8. Mohamed Daowd, Noshin Omar, Peter Van Den Bossche, Joeri Van Mierlo, — Capacitor Based Battery Balancing System, World Electric Vehicle Journal Vol. 5 - ISSN 2032-6653 - 2012 WEVA.
9. Sam Nork and Kevin Scott, — Passive Balancing Allows All Cells to Appear to Have the Same Capacity, Technical Article Analog Devices, Inc.

