



INTERNATIONAL JOURNAL OF CREATIVE RESEARCH THOUGHTS (IJCRT)

An International Open Access, Peer-reviewed, Refereed Journal

HOME AUTOMATION USING ARDUINO AND BLUETOOTH

¹Pravalika Bethi, ²Kukkala Ramya, ³Gande Preethi, ⁴Kokkonda Navya
¹ Graduation Student, ² Graduation Student, ³ Graduation Student, ³ Graduation Student
^{1,2,3,4}Electronics&Communication Engineering,
^{1,2,3,4} Balaji Institute of Technology and Science, Warangal, Telangana, India

Abstract: *The world is moving fastly towards automation. Individuals have less and ideal opportunity to deal with any work so automation is basic approach to deal with any gadget or machine will work to our craving. This paper point is to create and plan a Home automation using Arduino with Bluetooth module. Home automation framework gives a basic and solid innovation with Android application. Home appliances like fan, Bulb, AC, programmed entryway lock are controlled by Home automated framework using Arduino Uno with Bluetooth module. The paper for the most part centers around the screen and control of keen home by Android device and give a time saving savvy home, when the individuals are busy with their works at home. This paper motive is controlled home appliances in keen home with easy to understand, plan easily, straightforward establishment.*

Index Terms - Arduino, Home automation, Bluetooth, Smart phone.

I. INTRODUCTION

In Present days everybody has smart phone and wants to control everything from android device. Everyone is aware of how to control cell phone so it simple to utilize and comprehend. Lights, fan, switches, cooler are controlled through Bluetooth based far off utilizing Arduino. The planning of home automation will become easier and more famous on the grounds that the vast majority of individuals utilizes android now a days. In this gadget we are utilizing Arduino which is most ordinarily utilized gadget for computerization. Arduino is an equipment which is utilized to interface PC and the task model with the goal that we can control it by utilizing Arduino code as needs be. Arduino is a microcontroller it is much the same as human mind it measures data and afterward it plays out some Logical and numerical procedure on that data. Arduino is associated with the Bluetooth module which gets the data from client. Arduino likewise associated relay module, which gets data from Arduino and play out the activity as switch. Bluetooth innovation is Wireless radio transmissions in a short separation giving a vital innovation to make insight and controllability. This produces individual zone network in home condition, where every one of these machines can be interconnected and checked utilizing a microcontroller with Arduino utilizing smart phone. Home automation includes a level of mechanized or programmed control to certain electrical and electronic frameworks in a structure.

I. RESEARCH METHODOLOGY

In order to achieve this, a Bluetooth module is interfaced to the Arduino board at the receiver end while on the transmitter end, a GUI application on the cell phone sends ON/OFF commands to the receiver where loads are connected. By touching the specified location on the GUI, the loads can be turned ON/OFF remotely through this technology. When the power is turned on, the connection LED on the Bluetooth module starts blinking. We need to start the "Bluetooth Controller" app in our smartphone and get connected to the Bluetooth module. If the pairing is successful, the LED becomes stable. When a key is pressed in the smartphone, the Bluetooth module receives the corresponding data and intern transmits that

data to Arduino. Arduino then compares the received data with the data written in the sketch and accordingly turns on the load.

Those all parts are associated as appeared in figure 2(a).

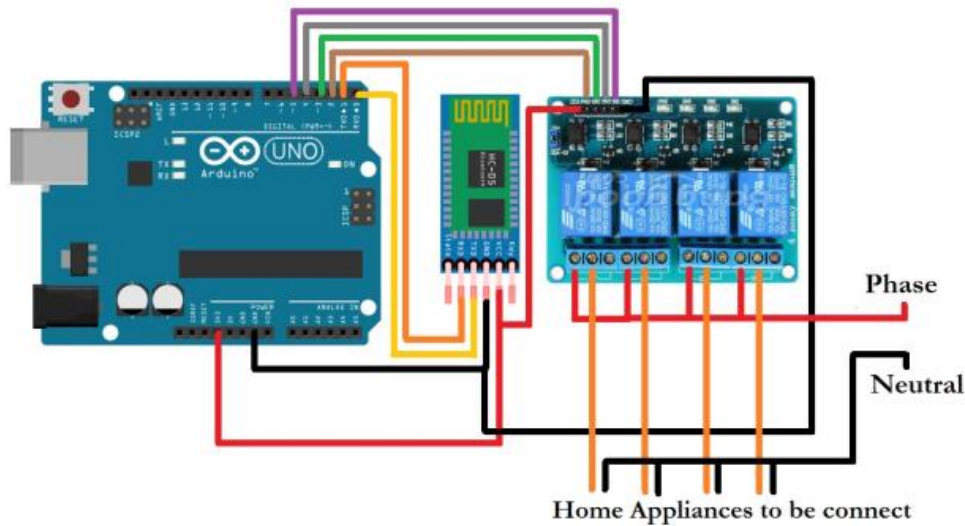

Fig2(a)-circuit diagram of home automation.

Android application are connected to the Arduino Bluetooth (HC-05). In the figure 2(b) we can see the devices. So, with that on/off options we can control the appliances connected to relay.

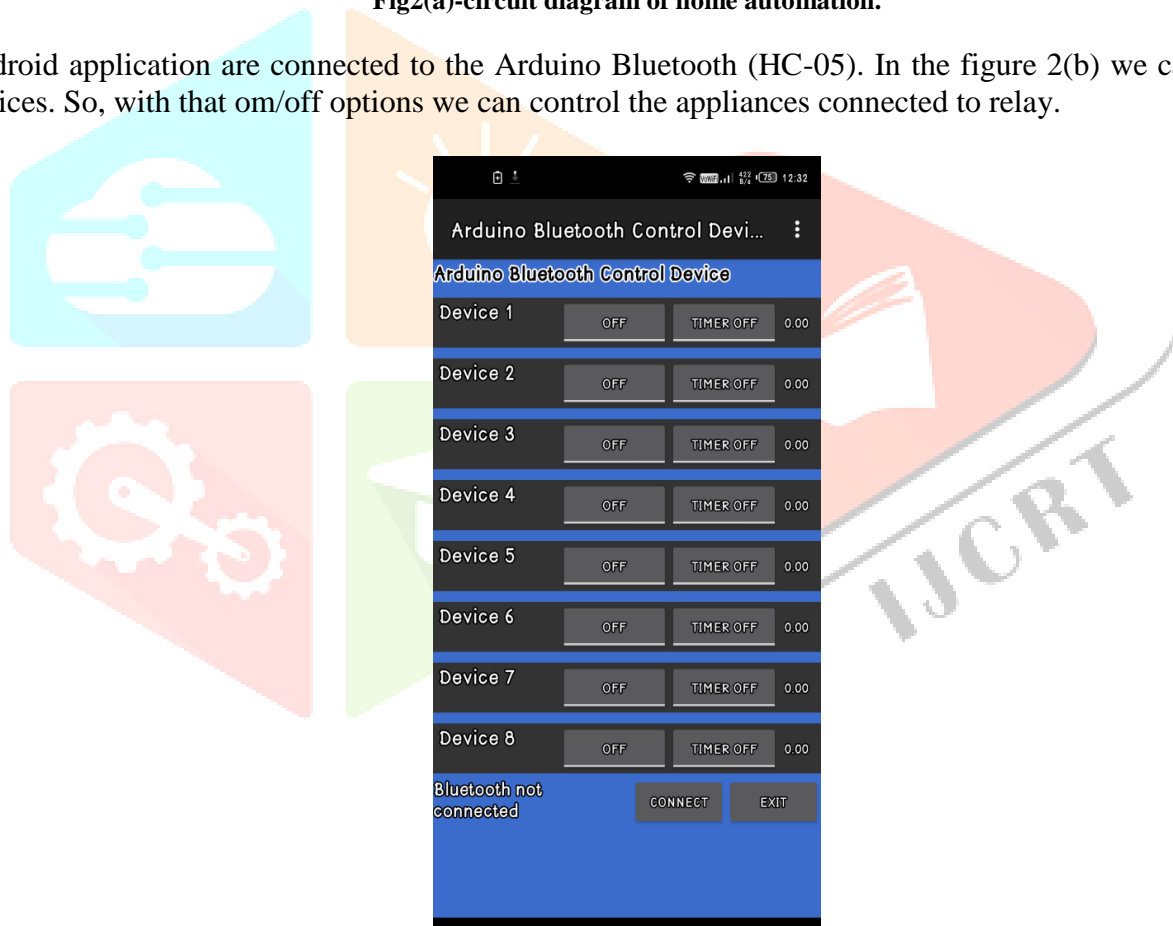

Fig.2(b)-Mobile android application.

III. Architecture of the Device

This venture centres around the automation of machines with the assistance of an android application. In this day and age, enhancement is the primary thought process. Any framework created goes for streamlining the human endeavours to a negligible and our framework goes for doing likewise. The architecture of this device as shown in figure 3(a).

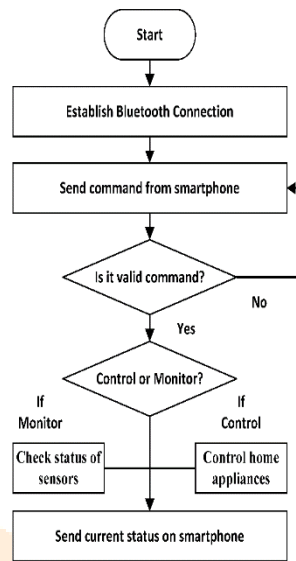

Fig3(a). Flow chart

The user will communicate to Android application through the Arduino Uno via Bluetooth module. This model is very resilient and gauge able, maximum efficiency, safety and securely added smart home appliances with least amount of human effort. The Bluetooth signal having most efficient energy to connect any signal without loss of information with least harmonics. Home automation system main part consists of Arduino with microcontroller. The people must have mobile application with proper connection. It should be used as multi appliances works as together. The Arduino board is configured for each home appliances using coding in microcontroller. By the help of Microcontroller, we can control the electromagnetic relay which works as a switch to receive a signal from the Arduino through Bluetooth module HC-05. When the signal transmits from transmitter as datasheet to relay then the relay works as switch and control many appliances of smart home(multitasking). There are three main parts of this home automation which is given below.

1. Arduino Uno
2. Bluetooth HC-05
3. Relay Drivers

IV. Description of Hardware

1. Arduino Uno: -

Arduino Uno is a microcontroller chip reliant on the Atmega328(datasheet) with 14 modernized I/o pins, in which 6 pins can be used as yields, 6 pins are used as straightforward data sources. It has 16 MHz earth resonator, a USB affiliation, a force jack and a reset button. The microcontroller has 32kB of ISP streak memory, 2kB RAM and 1kB EEPROM. The board gives sequential correspondence capacity through UART, SPI and 12C. Because of well plan the Arduino is straightforward. In Arduino we utilize significant level of programming language like C language, C++ language etc. It is straightforward and easy to use language. It has a lot of favorable position like performing multiple tasks, robotization, time area and so on. Arduino Uno fig4 (an) is given underneath.



Fig 4(a)- Arduino Uno

2. Bluetooth Module: -

HC-05 Bluetooth module is utilized to associate the microcontroller with android application. Bluetooth get the data from client and send to the microcontroller (Arduino Uno). It is easy to utilize Bluetooth Serial Port Protocol (SSP), planned as remote sequential association setup. The Bluetooth of sequential port module is Advanced Bluetooth v2.0+Enhanced information Rate at 3Mbps regulation with 2.4 GHz radio recipient with BB (base band). The Bluetooth of Rx and Tx pins are associated with the Arduino pins of Tx and Rx individually. HC-05 module is an easy-to-use Bluetooth SPP (Serial Port Protocol) module, planned for direct distant consecutive affiliation arrangement. It uses CSR Blue lope 04-External single chip Bluetooth system with CMOS development and with AFH (Adaptive Frequency Hopping Feature). It has the impression as meagre as 12. 7mmx27mm. The figure 4(b) of Bluetooth HC-05 module is given underneath.

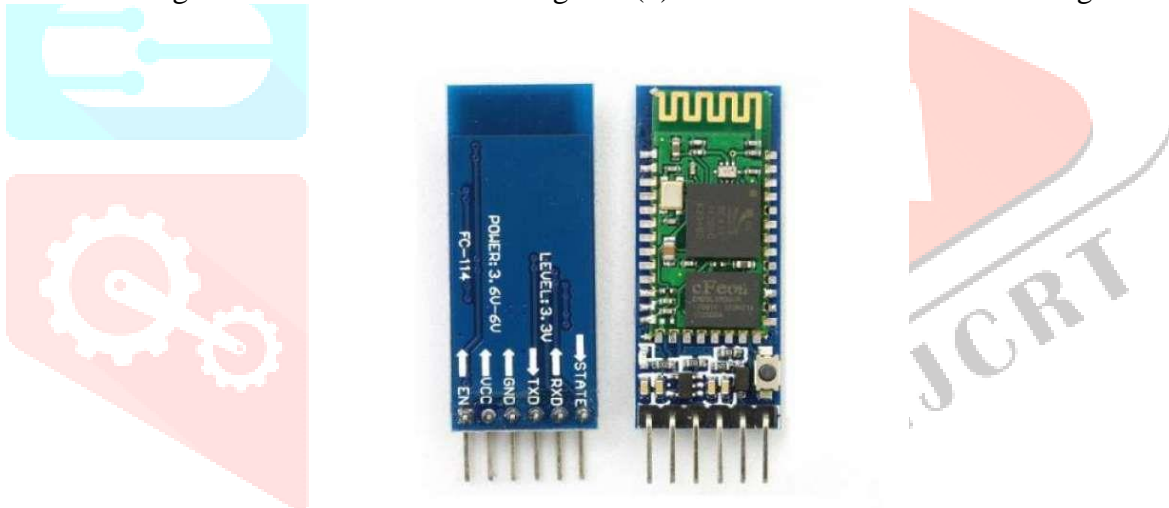

Fig 4(b) Bluetooth HC-05.

3. Relay Drivers: -

Relay is an electromagnetic switch which is used to defer two circuits electrically and connect magnetically. When Arduino transmit the signal then relay driver receive signal and start its work. They are frequently used to interface an electronic circuit (working at low voltage) to an electrical circuit which works at extremely high voltage. For instance, a hand-off can make a 5V DC battery circuit to switch 230V AC mains circuit. In this way a little sensor circuit can drive, say, a fan or an electric knob. A transfer switch can be separated into two sections: information and yield. The info area has a loop which creates attractive field when a little voltage from an electronic circuit is connected to it. This voltage is known as the working voltage. Generally utilized transfers are accessible in various arrangement of working voltages like 6V, 9V, 12v, 24V and so on. In a basic hand-off there are three contactors: ordinarily shut (NC), regularly open (NO) and normal (COM). At no info express, the COM is associated with NC. At the point when the working voltage is connected the transfer curl gets charged and the COM changes contact to NO. Diverse transfer setups are accessible like SPDT and DPDT which have distinctive number of changeover contacts. By utilizing legitimate blend of contactors, the electrical circuit can be turned on and off. Relay circuit shown in fig4(c).

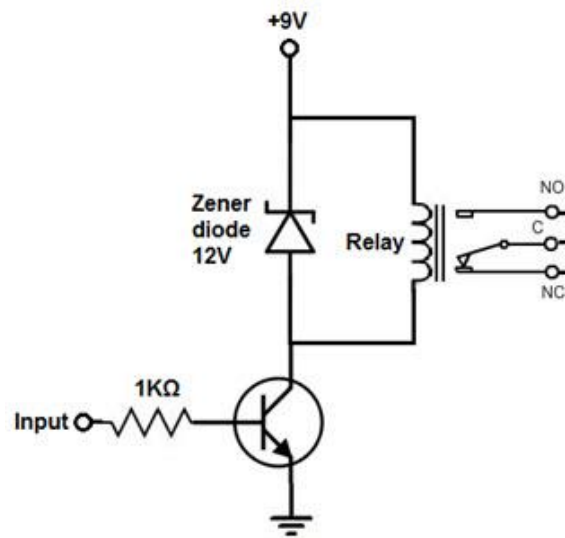

Fig 4(c) Relay circuit diagram

So as to drive the hand-off, we use transistor and just less power can be utilized to get the transfer driven. Since, transistor is an intensifier so the base lead gets adequate current to make increasingly current stream from Emitter of Transistor to Collector. In the event that the base once gets control that is adequate, at that point the transistor lead from Emitter to Collector and power the transfer. When the power is transmitting to the relay works as a switch due to electromagnetic effect so that we can switch ON or OFF our home appliances.

The figure 4(d) of relay is given below.



Fig 4(d) Relay module

V. Advantage

1. Everything is automated so it is easy to use.
2. It is control by mobile application so no extra training is required.
3. We can change controlling system as our requirement.
4. It works on Arduino based system so we can easily understand how it works.
5. It saves our time.
6. Every home appliance can control by one android application.
7. Easy installation and user friendly.

VI. Result

As indicated by the proposed arrangement the ultimate result of this paper prompts the advancement of a home mechanization. Through this undertaking, a computerization framework has been made with the goal that we can undoubtedly control home machines like as light, fan, tube light, AC, bulb, and so on. One of the goals of this task is likewise to get us a shrewd robotization and minimal effort venture. In this paper we have likewise given data about Arduino Uno, Bluetooth regulator and hand-off module. Also, the data about their work is given. Alongside the segment of home computerization, its preferred position has likewise been examined. The framework is simple and made sure about for access from subterranean insect client or gate crasher. Ultimate result of the undertaking is given underneath in fig 5(a)(b)(c)(d).

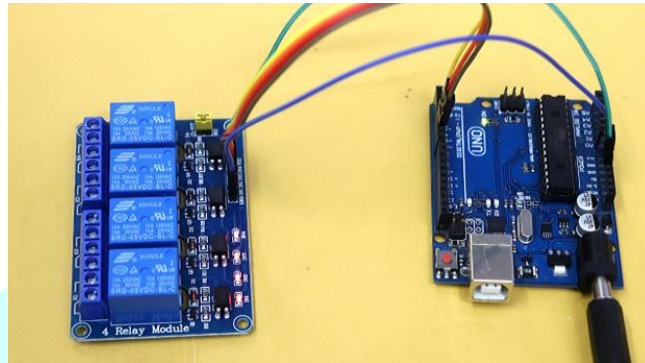

Fig 5(a) Arduino with relay module

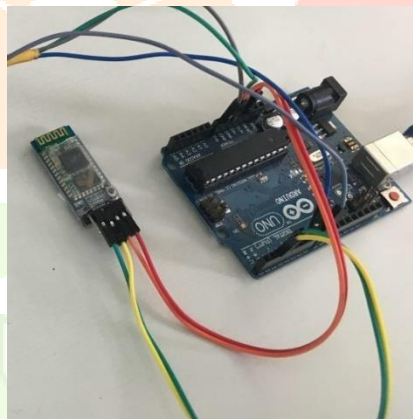

Fig 5(b) Arduino with Bluetooth

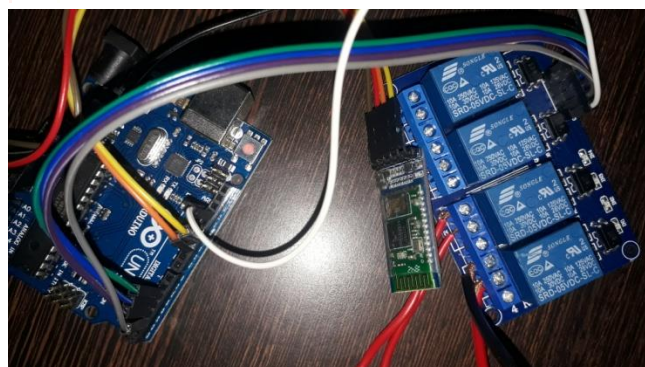

Fig 5(c) Relay module with Bluetooth

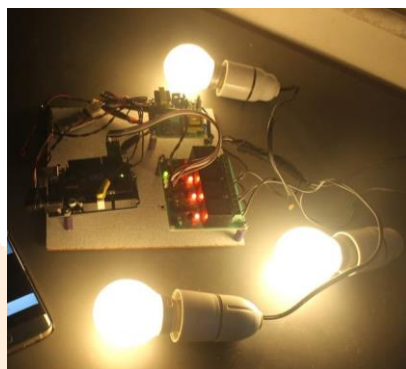
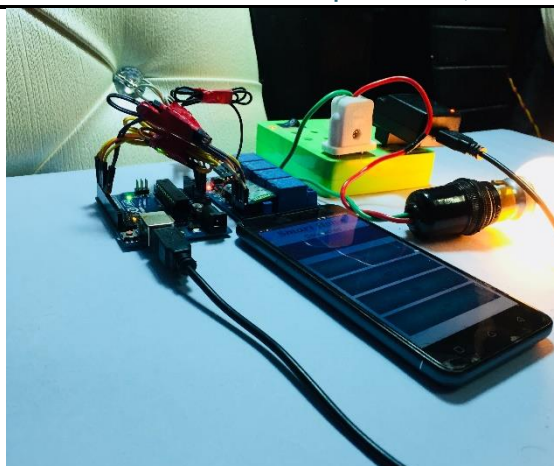

Fig 5(d) Home Automation

VII. Conclusion

It tends to be closed from the above conversation that Home robotization is an exceptional sort of gadget which controls home apparatuses with utilizing additional exertion. Furthermore, in this paper, we exhibited how the home computerization is made, examined about approach and what its application can be. What's more, later on, on the new innovation can be incorporated which lessens human exertion, which is being explored, we likewise discussed it. What's more, we've made a that sort of gadget which is conservative in size, minimal effort, greater limit, long life and more far-off sign recipients. The need of this examination paper is to make a gadget which spares the power and improve human way of life.

VIII. References

- [1]. Mitali Patil, Ashwini Bedare, Varsha Pacharne "The Design and Implementation of Voice Controlled Wireless Intelligent Home Automation System Based on ZigBee." International Journal of Advanced Research in Computer Science and Software Engineering
- [2]. Prof. M. B. Salunke, Darshan Sonar, Nilesh Dengle, SachinKangude, Dattatraya Gawade, "Home Automation Using Cloud Computing and Mobile Devices", Vol. 3, Issue 2 (Feb. 2013), ||V2|| PP 35-37
- [3]. N. David, A. Chima, A. Ugochukwu and E. Obinna," Design of a home automation system using Arduino", International journal of Scientific & Engineering Research, Vol. 6, pp. 795-801, june-2015.
- [4]. Ahmed Elshafee, Karim Alaa Hamed, "Design and Implementation of a Wi-Fi based Home Automation System", International Journal of Computer, Electrical Automation, Control and Information Engineering Vol: 6, No: 8, 2012, pp 1074 - 1080.
- [5]. Zekeriyakeskin, Yunus Emrekocaturk, okan Bingol, Kublai Tasdelen, "Web-based smart home automation: PLC controlled implementation", vol11, NO 3, 2014.
- [6]. Mansour H. Assaf, Ronald Mootoo, Sunil R. Das, Emil M. Petriu, Voicu Groza, and Satyendra Biswas "Sensor Based Home Automation and Security System." 978-14577-1722-7/12/\$26.00 ©2012 IEEE.