



Design and Evaluation of Arc welded MS & SS plates to find the effect of bend radius at different load conditions

¹P. Varalakshmi, ²Guda Revanth Kumar, ³Datrika Sri Harshitha, ⁴Aska Mukhul Vamshi, ⁵Chetty akhila

¹Assitant Professor, ²³⁴⁵Student,

¹²³⁴⁵Mechanical Department,

¹²³⁴⁵Guru Nanak Institute of Technology, Hyderabad, Telangana, India.

Abstract—

Arc welding is a process of joining metals by using electrodes, by using high heat to melt the parts together and allow them to cool causing fusion. It is a type of welding to join metals, other than joining process like brazing and soldering. We have used two different metals like Mild steel (MS) and Stainless steel (SS) plates with different thickness about 8mm and 10mm. We have done Arc welding on MS and SS plates with different thickness. By using electrode E7018 with different gauges like 2mm, 3.5mm, 4mm for (filling V-GROVE) applying 3 layers of weld bead, for finding the welding defects on weld joint. The following tests conducted are hardness, dye-penetration, Magnetic and radiography. We mainly concentrated on finding the effect of bending radius on weld joint. By applying the different loading conditions bend radius and angle of inclination are obtained. With the help of CAD (computer aided design) application with CREO parametric, we have designed the welded plates and performed analysis using ANSYS software. By using this software, the theoretical and experimental values are evaluated.

Keywords: Arc welding, MS and SS plates, electrode, CAD, CREO, ANSYS.

I. INTRODUCTION

CREO Parametric is a modern computer aided design (CAD) program. It enables designers to create a mathematically correct solid model of an object that can be stored in a database. When the mathematical model of a part or assembly is associated with the properties of the materials used, we get a solid model that can be used to simulate and predict the behavior of the part or model with finite element and other simulation software. The same solid model can be used to manufacture the object and also contains the information necessary to inspect and assemble the product. The marketing organization can produce sales brochures and videos that introduce the product to potential customers. CREO Parametric and similar CAD programs have made possible concurrent engineering, where all the groups that contribute to the product development process can share information real-time.

ANSYS is engineering simulation software that predicts with confidence about the performance of the product under the real-world environments incorporating all the existing physical phenomena. While performing the part of composite analysis, the composite properties were imposed only in the full-length leaves by incorporating the new value of elastic modulus obtained from the rule of mixtures. The layout of static analysis involves meshing, boundary conditions and loading.

Welding is a process of joining two similar and Non-similar metal or non-metal with the application of heat and pressure, but in some cases without the application of pressure the process has been done. The electrode is used to join the metal in Arc welding process with the help of spool gun. Welding is used for making permanent joints[7]. It is used for the manufacturing of automobile parts, railway wagons, aircraft frames, machine parts, tanks, structural works, boilers, ship building furniture etc. Arc welding is a process which produces the coalescence of metals by heating them with an arc between a continuously fed filler metal electrode and the work[1].

These are the parameters that are used for the Arc welding process. By this we can do the arc welding with the represented size of the electrode and the type of the electrode that used[2].

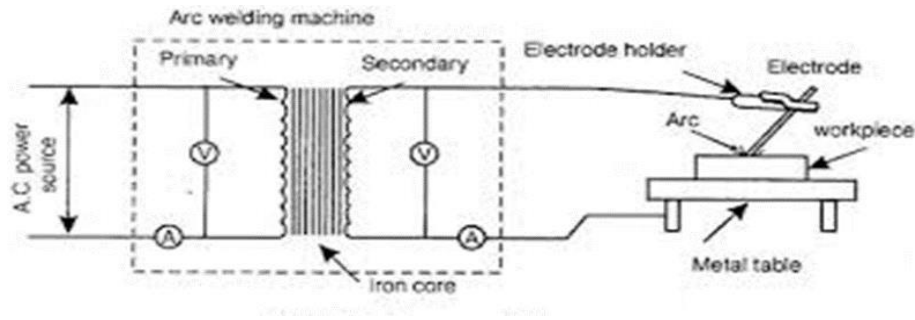

Figure- Arc welding process

For finding the bend radius, The bend allowance (BA)[8] is the length of the arc of the neutral line between the tangent points of a bend in any material. Adding the length of each flange taken between the center of the radius to the BA gives the Flat Pattern length. This bend allowance formula is used to determine the flat pattern length when a bend is dimensioned from 1) the center of the radius, 2) a tangent point of the radius or 3) the outside tangent point of the radius on an acute angle bend. There is a procedure to find the end radius

1. Design of weld joints
2. Testing the joints both practical and analytical
3. Comparing the both analytical and practical values

II. DESIGN OF WELD JOINTS:

For designing the weld joint plates we have taken CREO Parametric software. In this software first we have designed the plates as shown in the figure then we have weld the joints in the software by using applications in the software. The steps involved in the Creo parametric software are

- select the geometry setup
- select the type of material that setup for the part
- create 2D model
- modify constraints and dimensions
- complete the solid model

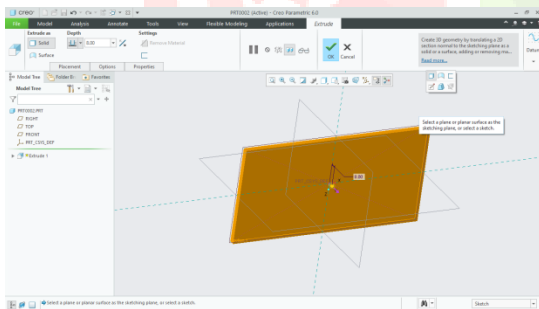

Figure-Creating the plates

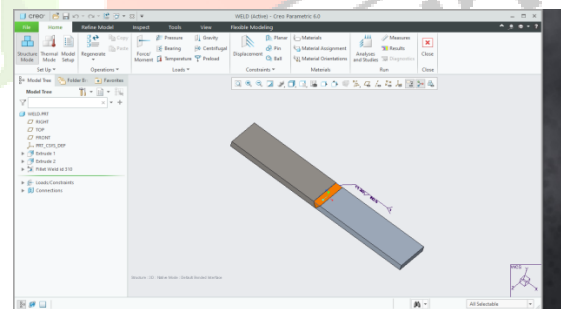

Figure- welding the plates

III. WORKING PROCESS OF ARC WELDING

Arc welding is a process to join two different metals by using electrode, the steps required for the working process[11].

- selection of electrode
- welding
- testing
- results

The electrode selected for the welding is MSE7018 electrode at different diameter the welding is done[9].

The welding is done according the conduction for 8 mm and 10mm plates, the weld done by three different diameters 2.0, 3.15 & 4.0 The conduction table is drawn according to the conduction taken for the welding[10].



Figure-electrode E7018



Figure – welding the MS&SS plate

Table-1: conduction for welding on 8mm thickness plates

S. NO	Diameter of electrode (mm)	SWG	Voltage (volts)	Current (amps)
1.	2.0	12	30	50
2.	3.15	10	30	100
3.	4.0	8	25	80

Table-2: conduction for welding on 10mm thickness plates[14]

S. NO	Diameter of electrode (mm)	SWG	Voltage (volts)	Current (amps)
1.	2.0	12	30	75
2.	3.15	10	35	110
3.	4.0	8	35	100

- From the above table-1 and table-2 we represent that the Arc welding is done by three electrodes one after the other to join the weld plates in single process by layer by layer (for both 8mm and 10mm thickness plates)[12][13].

IV. TESTING THE WELD JOINTS

After welding there two different tests to be conducted that is Destructive test and non-destructive test

- Destructive Testing is defined as a software testing type to find points of failure in a software program. It is a testing method where an application is intentionally made to fail to check the robustness of the application and identify the point of failure. Unlike other testing method which checks the function of an application, this technique will check the unpredictable user behavior within the application. For Destructive Testing, it is not necessary to have the knowledge of the original requirements of a software product. However, some knowledge could help in developing a good testing strategy. In destructive testing (or destructive physical analysis, DPA) tests are carried out to the specimen's failure, in order to understand a specimen's performance or material behavior under different loads. These tests are generally much easier to carry out, yield more information, and are easier to interpret than nondestructive testing. Destructive testing is most suitable, and economic, for objects which will be mass-produced, as the cost of destroying a small number of specimens is negligible[3].
- Non-destructive testing (NDT) is a wide group of analysis techniques used in science and technology industry to evaluate the properties of a material, component or system without causing damage.[6]. The terms non-destructive examination (NDE), non-destructive inspection (NDI), and non-destructive evaluation (NDE) are also commonly used to describe this technology. Because NDT does not permanently alter the article being inspected, it is a highly valuable technique that can save both money and time in product evaluation, troubleshooting, and research[4].

The main test is bending test and tensile test in our project, both are destructive tests by this test we can find the effect of bend radius at different loading conditions. These are the parameters that are used for the Arc welding process. By this we can do the arc welding with the represented size of the electrode and the type of the electrode that used. For finding the bend radius, The bend allowance (BA) is the length of the arc of the neutral line between the tangent points of a bend in any material. Adding the length of each flange taken between the centers of the radius to the BA gives the Flat Pattern length. This bend allowance formula is used to determine the flat pattern length when a bend is dimensioned from 1) the center of the radius, 2) a tangent point of the radius or 3) the outside tangent point of the radius on an acute angle bend[5].



Figure- Bend radius for metal plate

V.RESULTS

BENDING TEST FOR PRACTICAL:

Table-3: Bending test results for 8mm

SNO	Thickness of the plate	Load(KN)	Displacement (mm)
1	8mm	0	0
2	8mm	5	14
3	8mm	10	33
4	8mm	15	80

Graph: Bending test graph for 8mm

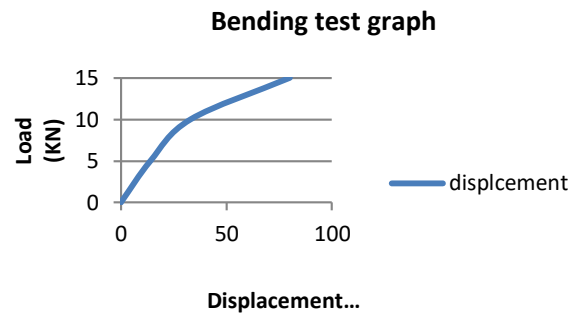

1. Bending radius for 8mm plate at various load conditions

Bending radius is represented in images below according to the load acting on weld joint.

1. for load zero

- The bend radius is 0
- Elongation is 0

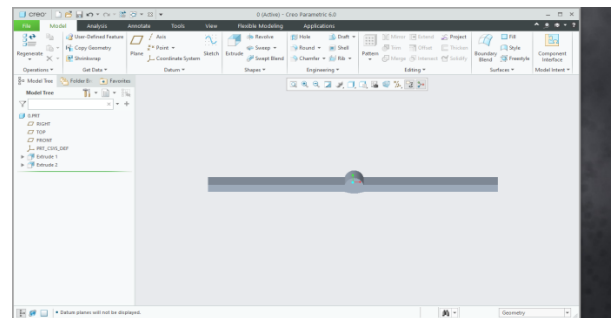

2. for load 10

- the bend radius is 12
- the elongation is 33

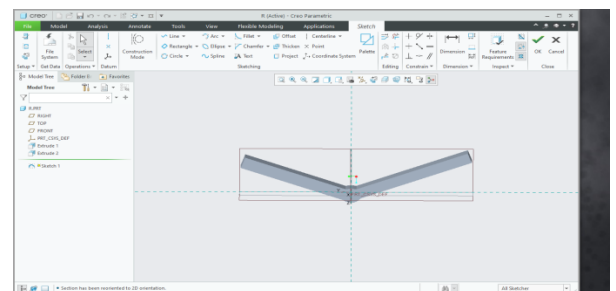

3. for load 15

- The bending radius is 40
- Elongation is 80

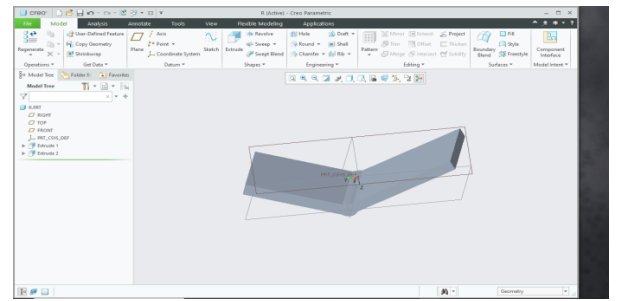
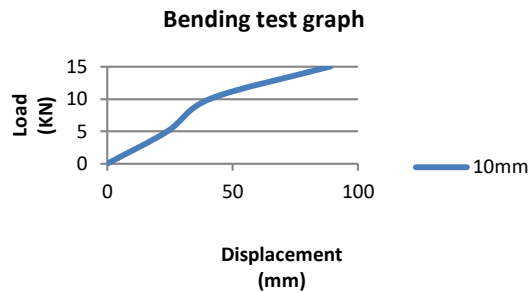

Table-4: Bending test results for 10mm plate

SNO	Thickness of the plate	Load(KN)	Displacement (mm)
1	10mm	0	0
2	10mm	5	24
3	10mm	10	41
4	10mm	15	89

Graph: Bending test graph for 10mm plate



2. Bending radius for 10mm plate at various load conditions

Bending radius is represented in images below according to the load acting on weld joint.

1. for load 0

- The bending radius is 0
- Elongation is 0

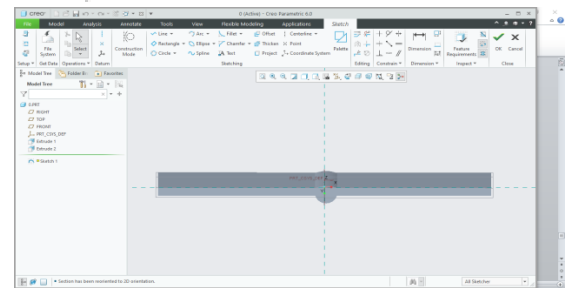

2. for load 10

- The bending radius is 21
- Elongation is 41

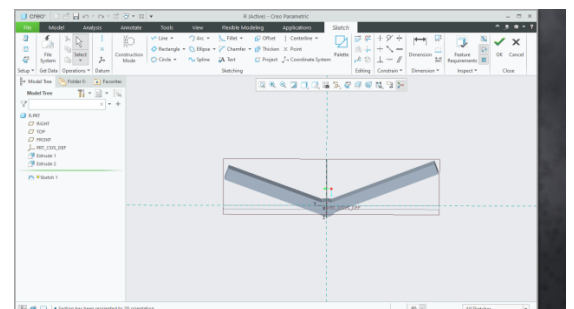

3. for load 17

- The bending radius is 41
- Elongation is 89

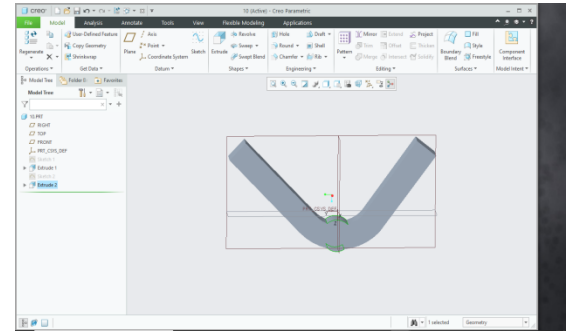

BENDING TEST IN ANSYS

- Bending plate for 8mm

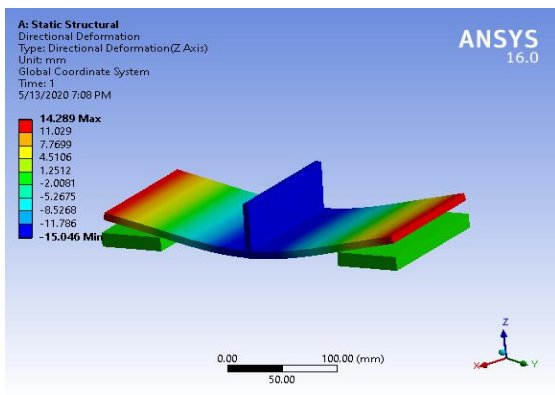

Fig Direct deformation for the root of 8mm plate

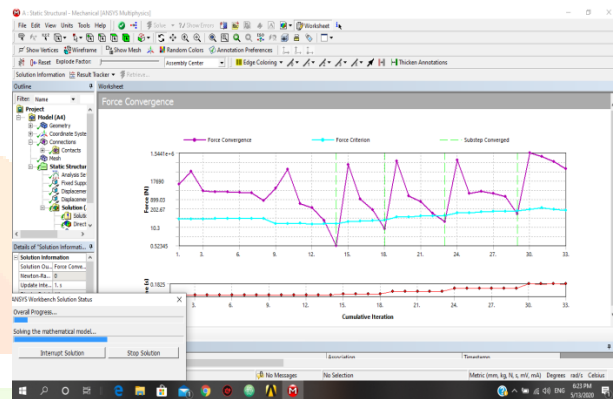

Fig force convergence graph for 8mm plate

- Bending plate for 10mm

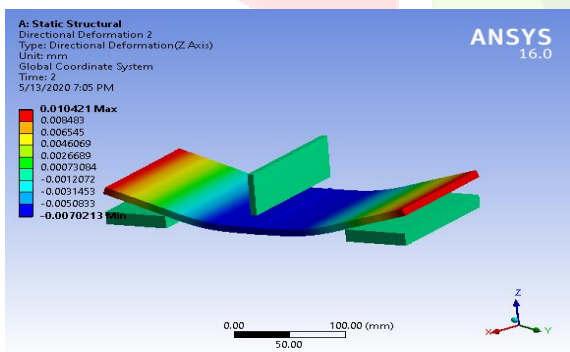

Fig Direct deformation for 10mm plate

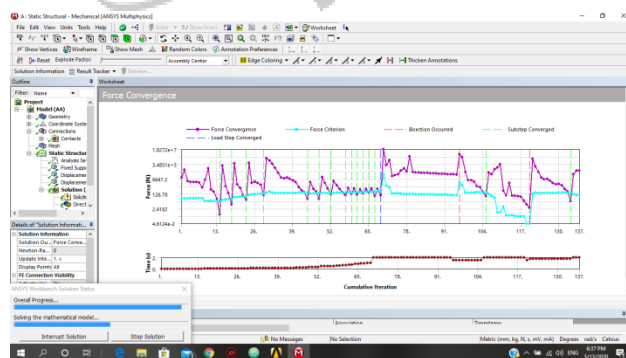
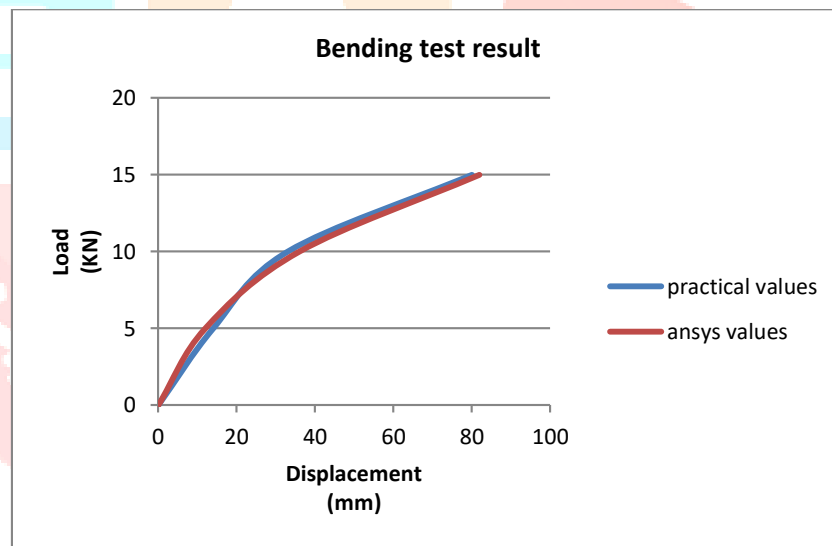

Fig force convergence graph for 10mm plate

EVALUATION OF RESULTS FOR BENDING TEST:**Table-5: Evaluation of results for bending test for 8mm plate**

SN O	TEST	Thickness of plate	Practical value		ANSYS value	
			Load (KN)	Displacement (mm)	Load (KN)	Displacement (mm)
1	Bending test	8mm	0	0	0	0
		8mm	5	14	10	12
		8mm	10	33	20	36
		8mm	15	80	30	82

Graph: Comparison of bending test result graph for 8mm**Table-6: Evaluation of results for bending test for 10mm plate**

SNO	TEST	Thickness of plate	Practical value		ANSYS value	
			Load (KN)	Displacement (mm)	Load (KN)	Displacement (mm)
1	Bending test	10mm	0	0	0	0
		10mm	5	24	10	22
		10mm	10	41	20	56
		10mm	15	89	30	92

Graph: comparison of bending test result graph for 10mm

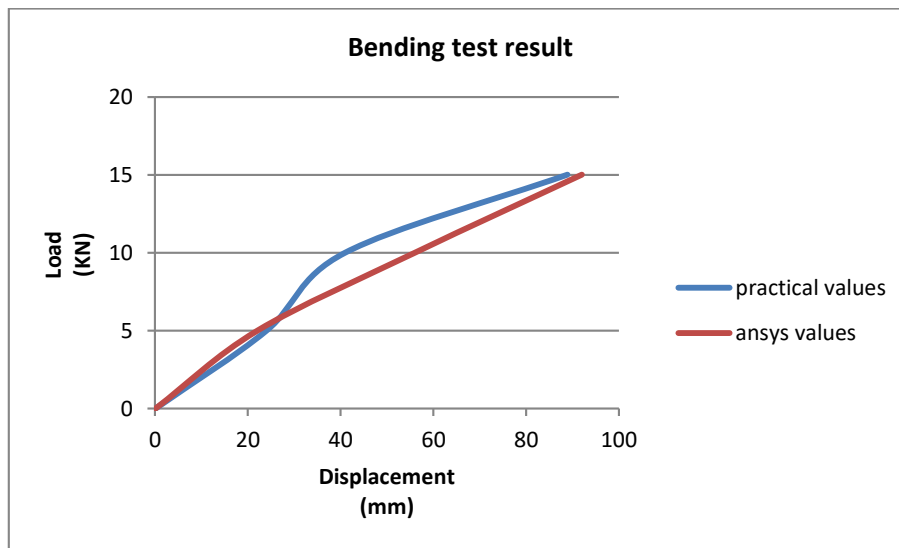

VI. CONCLUSION

From the results derived from the project we conclude that.

- The arc welding is a process to use to join two different metals easily
- By using the processes of welding the parameters and the welding qualities increased and joint become strong.
- After performing the different tests the problems arise due to weld defects are due to an improper welding procedure. Once the causes are determined, the operator can easily correct the problem. Defects usually encountered include incomplete penetration, incomplete fusion, undercutting, porosity, and longitudinal cracking.
- Ansys software is used to perform various tests by using computer-aided diagram like cad models as same as the weld joints there is slight variation in the results due to capability of the parameters and the high performance of the software.
- To overcome defects: Prevent these types of weld defects by using the right metal. You'll need to remove the impurities in your metal and preheat it as required. Additionally, use the proper joint design for the material and properly cool the welded area. Be sure to weld enough sectional areas.
- By evaluating the both practical and computerized tests that performed in the project represents the elasticity, stress, strain and elongation obtained by the results are more efficient than other weld joints.
- Finally we prefer the arc welding process is well and simple for the joining of two different metals and also improves weld quality

VII. FUTURE SCOPE

- Now a days welding is the major process to joining materials, these are different types of new welding process are used for advance technology. For example like wet welding and dry welding mainly implementing underground welding
- In addition, further study into welding of unequal gauge materials or dissimilar alloys would provide a more thorough understanding of the capabilities of friction stir welding and possible applications for use. The temperature needs for each different material will be important to consider while welding dissimilar alloys.
- The research could be taken further by applying the same technique to other Aluminum alloys which are used in the automotive industry. This could help the increase of use of the friction stir welding in the automotive industry.

VIII. REFERENCES

- 1) <https://www.britannica.com/technology/welding>
- 2) <https://www.britannica.com/technology/welding#ref7847>
- 3) <https://www.adhesiveandglue.com/destructive-testing.html>
- 4) <https://www.ndeed.org/EducationResources/CommunityCollege/PenetrantTest/PTMaterials/surfaceenergy.htm>
- 5) <https://www.twi-global.com/what-we-do/services-and-support/asset-management/non-destructive-testing/ndt-techniques/radiography-testing>
- 6) <https://www.caltec.ca/about-us/blog/4-main-types-ndt-testing>
- 7) *Tejpal singh, arivendhar singh, sumith saini, effect of groove design on mechanical properties of SMAW joints.vol25:665-669(2015)*
- 8) *Rouhollah Mohsen pezeshkian, peyaman shayanfar, groove angle influence on mechanical and microstructural properties of P460 steel in SMAW. Vol27:586-598(2010)*
- 9) *Saiedeh Safaiepour, experimental study of shielded arc metal welding parameter on weld strength for AISI1020.vol26:1252-1265(2011)*
- 10) *Ipek, Elaldi analysis of welding groove angle and geometry on strength of armour steelvol.27:1437-1447(2012)*
- 11) *Ling, Fuh, Huang, Wu groove configuration of a flux cored arc welding processes, the international journal of advanced manufacturing technology.vol25:366-375(2012)*
- 12) *Bekir Cevich analysis of welding groove configuration of the strength of S275 structural steel welded by SMAW, vol.30:224-240(2010)*
- 13) *Li, orme, yu, effect of joint design on mechanical properties of A17075 weldment, journals of materials engineering and performance. Vol14:322-326(2012)*
- 14) *Kaya, kahraman, durgutlu, gulench investigation of mechanical properties of different thickness of the the grade A ship plate joined by submerged arc welding. Vol24:633-640(2010)*

