



INTERNATIONAL JOURNAL OF CREATIVE RESEARCH THOUGHTS (IJCRT)

An International Open Access, Peer-reviewed, Refereed Journal

Invention Of New Diagnostic Electronic Stethoscope

ErWani Sageer¹

Binti-Islam², Hilal Ahmed Hajam³, Aamir Reyaz Sheikh⁴, Muzafar A. Ganie

Abstract: The present invention was directed to a stethoscope system, which includes a local stethoscope unit with a chest piece assembly to generate a first analog auscultation signal and two inches PVC tubing which also acts as a mechanical low pass filter and prevents external scratching noise of hand during auscultation. A diaphragm of acoustic capacitive transducer is to receive the first analog auscultation signal. The present invention also is directed to a stethoscope system comprising a capacitive microphone unit. One novel feature of the device of the present invention is the use in the stethoscope units of a low frequency boost to improve the low frequency response down to approximately 20 Hz. The switchable bell/diaphragm and extension mode enables to auscultate a desired sound frequency performance bandwidth and for enhanced the bell-diaphragm characteristics of a traditional stethoscope. Another novel feature of invention is that it provides an efficient, low cost, low noise stethoscope system using a low cost low noise op amp. Another feature of the present invention is that it provides conversion of arterial sounds into graphic output via PC based oscilloscope software which leaves less chance of observation error.

Key words: auscultation, acoustic, capacitive, transducer, traditional, stethoscope.

I. INTRODUCTION:

Very simple device, the stethoscope is one of the most important diagnostic tools in the medical world. Over almost two centuries, the stethoscope has been changed and refined often, but it has never strayed too far from the original design. Rene Theophile, a French physician, is attributed with the invention of the first stethoscope in 1816 when he was examining an obese patient. His first model of the stethoscope was simply a wooden tube resembling a candlestick. Over the years, this model has evolved into the device that we now recognize as the stethoscope through many small changes, such as adding earpieces for each ear and developing the combined bell and diaphragm chest piece. Very few changes have been made to the model of the stethoscope since 1961, when Dr. David Littman patented a new, lighter model with a single binaural tube that drastically improved the acoustic technology. The stethoscopes that are now commonly used are called "Littman stethoscopes" for this reason.

Very few changes have been made to the overall design of the stethoscope over the years because it does its job so well. However, there are a few problems with current models. For example, with the standard acoustic stethoscope, the listener is not able to amplify the sounds.

This is sometimes a problem if he or she is only getting very quiet sounds through the stethoscope. Also, the

earpieces of stethoscopes can be quite uncomfortable. Although these are not enormous problems, current technology has introduced alternatives to the acoustic stethoscope.

In 1961, Littman patented his new model and another company named Amplivox produced the first electronic stethoscope. It was only meant to be an academic tool due to its large size and weight, and it also produced distinctly different sounds than what doctors were used to hear. Because of this, the idea was largely abandoned, and users returned to the conventional stethoscope. However, some companies have returned to this idea and have introduced new devices to the market. Some enhancements that modern electronic stethoscopes have sound transducers, adjustable gain amplifiers and frequency filters.

Although these improvements have been made, the electronic stethoscope still has not been embraced by the medical community. This is because the sounds that the listener receives through the earpieces are mixed with electronic noise, causing the sounds to be different than the non-electronic, acoustic stethoscope. Also, electronic stethoscopes are very sensitive to surrounding noises, and these will overpower the sound of the heart and lungs. Many electronic stethoscopes in the market do not have the original bell and diaphragm or tubing, which help filter background noise and produce a sound that the listener is more familiar with.

Electronic stethoscopes, like standard acoustic stethoscopes, only allow one listener, which is not preferable for a teaching environment. They also are about \$400 MSRP, which is much more expensive than an acoustic model. This project will fix many of the problems of currently marketed electronic stethoscopes at a very low cost.

Objectives: Major objectives were to devise a Diagnostic electronic stethoscope unit that would be:

- Cost effective and non invasive
- Having lower power consumption
- Extremely accurate with less chances of observation error i.e. close to acoustic
- Having best sound quality with extremely low noise
- Having proper amplification factor to adjust for heart sounds in obese, pregnant patients.

II. SUMMARY OF THE PROPOSED INVENTION: DIAGNOSTIC ELECTRONIC STETHOSCOPE:

The present invention is directed to a stethoscope system, which includes a local stethoscope unit with a chest piece assembly to generate a first analog auscultation signal and two inches PVC tubing which also acts as a mechanical low pass filter and prevents external scratching noise of hand during auscultation. A diaphragm of acoustic capacitive transducer is to receive the

first analog auscultation signal. The present invention also is directed to a stethoscope system comprising a capacitive microphone unit.

One novel feature of one embodiment of the present invention is the use in the stethoscope units of a low frequency boost to improve the low frequency response down to approximately 20 Hz. The switchable bell/diaphragm and extension mode enables to auscultate a desired sound frequency performance bandwidth and for enhanced the bell-diaphragm characteristics of a traditional stethoscope. Another novel feature of one embodiment of the present invention is that it provides an efficient, low cost, low noise stethoscope system using a low cost low noise op amp.

Another novel feature of one embodiment of the present invention is that it provides conversion of arterial sounds into graphic output via PC based oscilloscope software which leaves less chance of observation error.

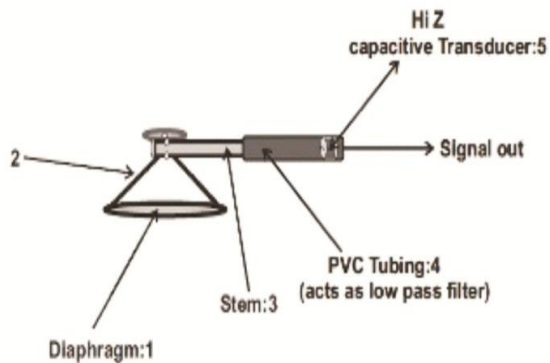
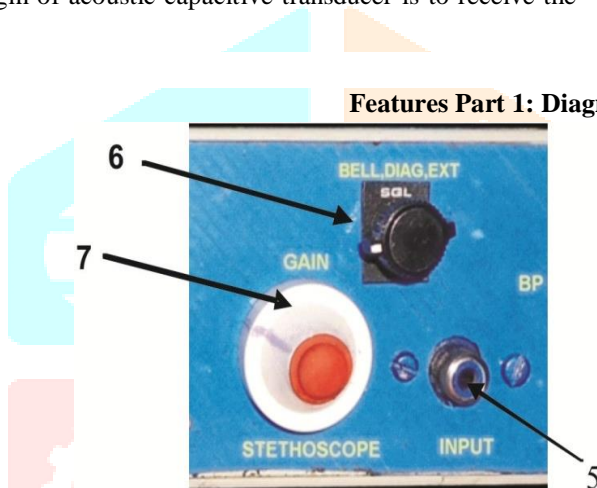

It has three filter modes

- BELL
 - DIAPHRAGM
 - EXTENDED MODE.
- Bell mode receives low frequency sounds within the range of 20Hz~200Hz,
 - The diaphragm mode receives higher frequency sounds within the range of 200Hz ~600Hz.
 - The extended mode receives the frequencies upto 2.5 KHZ

The significant features include:

- Best sound quality
- High gain
- Very Low Noise
- Low Distortion
- 30X Plus Amplification provides the power to adjust for faint heart sounds in obese patients & noisy environments.
- It can also be used on pregnant woman for fetal auscultation.

The Drawings, Block diagram, Pictures, schematic design and Block diagram used in the project are shown in Figures:- 1,2,3,4,5,6,7 & 8..

BRIEF DESCRIPTION OF THE FIGURES

A more complete appreciation of the present invention and many of the attendant advantages thereof will be readily obtained as the same becomes better understood by reference to the following detailed description when considered in connection with the accompanying figures, wherein:

(FIG. 1) is a complete block diagram of a Low Noise Stethoscope.

(FIG. 2) is a binaural piece and PVC tubing arrangement connected to the sound transducer through silicone rubber and PVC tubing.

(FIG: 3,4,5) is a Complete construction method and pictures of stethoscope head of the present inventions:

(FIG. 6) is a complete schematic diagram of the stethoscope.

(FIG-7) is graph of Noise figure versus Frequency.

(FIG-8) is screen shot of Noise figure of present embodiment taken from the PC based oscilloscope.

CLAIMS (4) Part 1: Diagnostic electronic stethoscope

I do claim that stethoscope system, comprising: a local stethoscope unit including a chest piece assembly to generate a first analog auscultation signal and a capacitive transducer to receive the first analog auscultation signal; and to convert into varying electrical signal which is received from polyvinyl chloride tubing for acoustic resonance and low pass filtering.

The local analog signal is fed to a filter, Sallenkey first order means to filter out the desired signal with a gain of one. Section

including a first low frequency boosts circuit coupled to the chest piece assembly and capable of amplifying a portion of the first analog auscultation signal having frequencies between 20Hz and 2500Hz.

1. The stethoscope system according to claim 1, wherein the local stethoscope unit further includes a local headset to generate analog auscultation signal;
2. The stethoscope system according to claim 2, wherein the filtered output signal is fed to the low noise amplifier means to amplify the signal, means to become input signal to headphone driver for further amplification to drive headset.

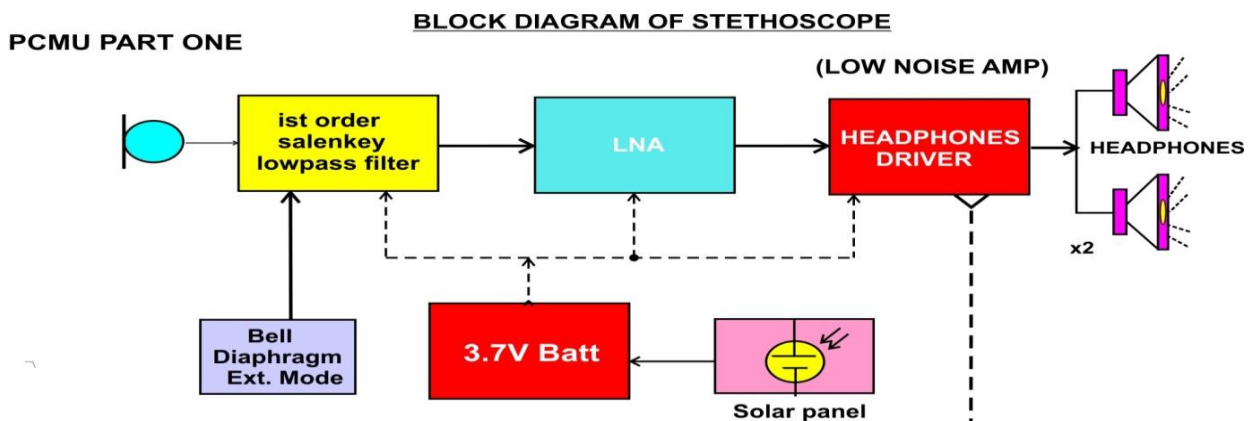

Fig: 1

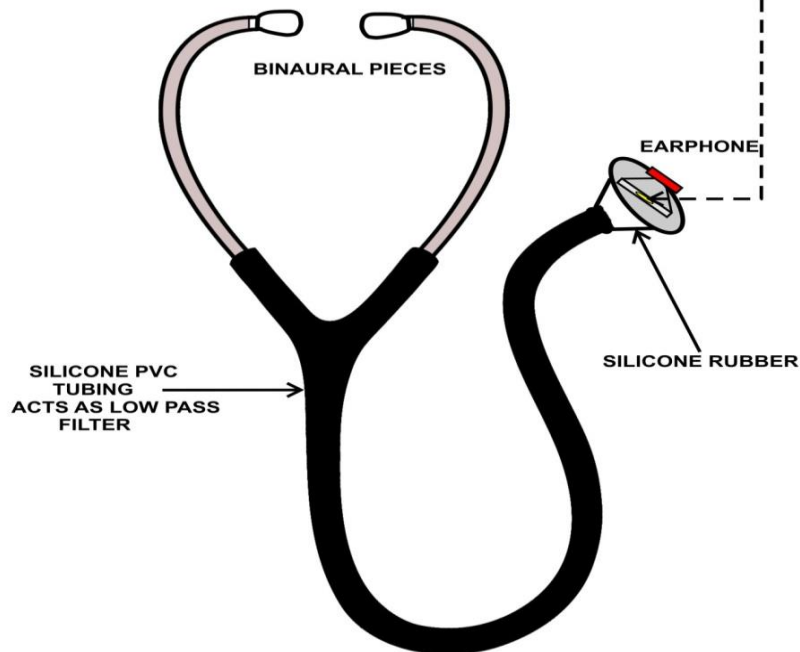

Fig: 2

PCMU PART ONE

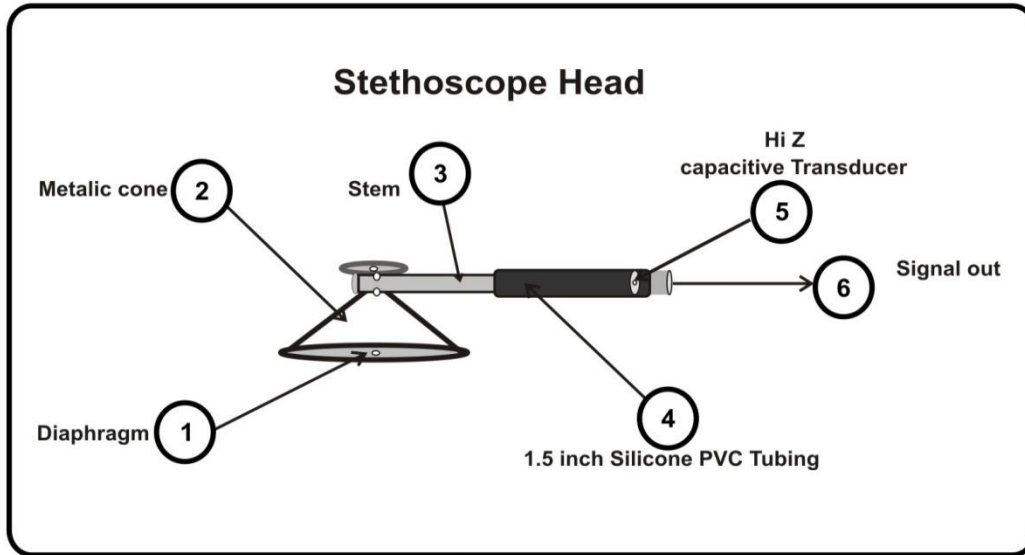

Fig: 3



Fig: 4



Fig: 5

PCMU PART ONE

Complete Schematic Of Stethoscope

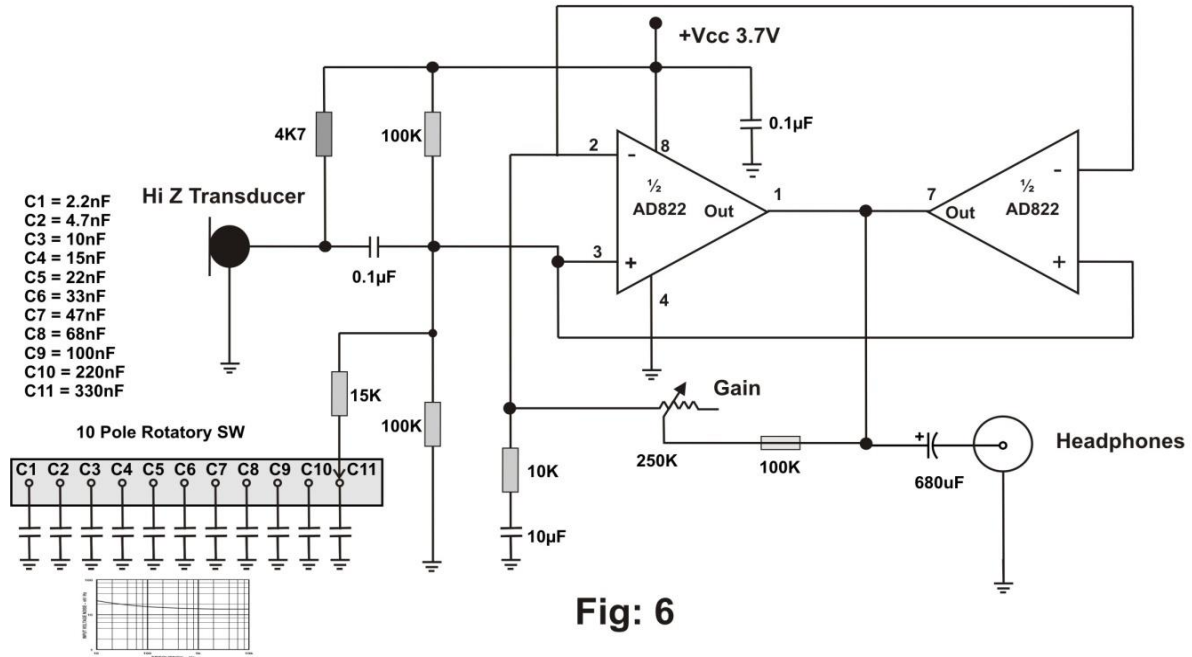

Fig: 6

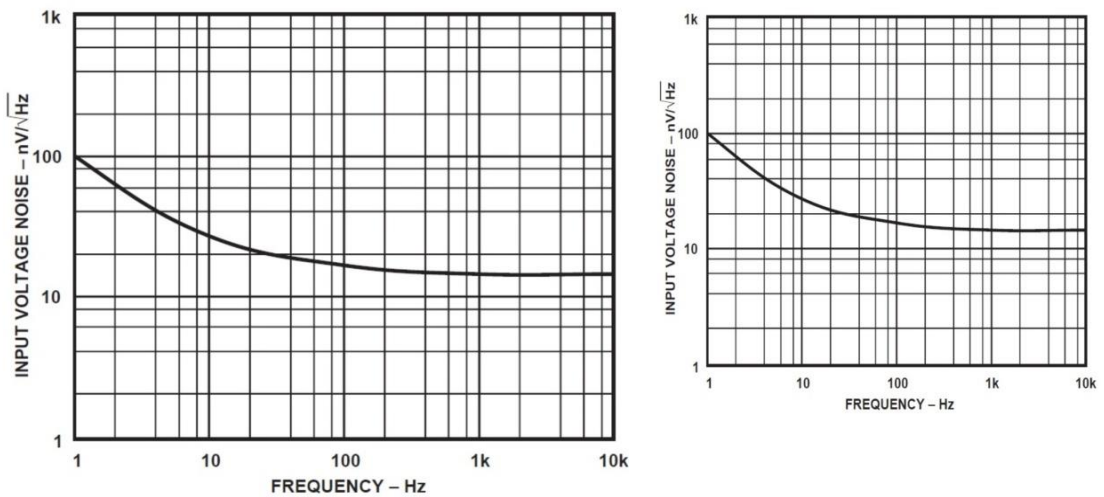

Fig: 7

PCMU PART ONE

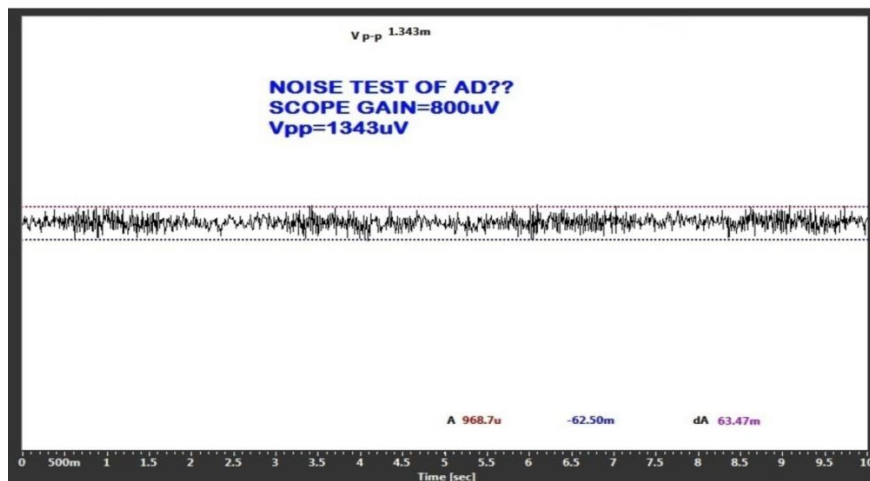

Fig: 8

III.RESULTS AND EVALUATION:

Clinical Testing:

The human heart has very low frequency sounds and complex resonances which artificial transducers don't accurately reproduce. Thus we conducted loudness testing using human volunteers by measuring the relative loudness of their heartbeat with the various stethoscopes. We used a free version soundcard software 2011. V1.41 beta by C zeitnitz to measure frequency sweeps and dirac pulses (clicks). We developed a test jig to mate both stethoscope earpieces to a sound pressure level meter. The sound pressure level meter has a microphone, preamp output, and a calibrated variable gain control. The preamp output was attached to the line input of a desktop soundcard on a Windows 7 platform, and were recorded as .wav files.

Power spectra analysis and Fourier analysis of the .wav files were done with commercial software.

Loudness testing was done using human volunteers. We used two volunteers, one male, and one female and recorded heart sounds for each using each scope, in duplicate. The control was the microphone of the sound pressure meter placed directly

against the chest. We found that most of the stethoscopes amplified sounds below 100 Hz, and attenuated sounds above 200 Hz. Results were measured as the decibels of sound amplification at the peak of the human heart sound power spectra, typically at 30 Hz in our subjects. Amplification of 15 Db was assigned a value of 10 points on our chart. The DRG scope had the highest peak sound intensity.

Clarity testing was done using the Sennheiser transducer to generate Dirac pulses (clicks). We found that all of the scopes attenuated the clicks. The DRG had the worst performance in this test with 21 DB of attenuation. Results are again expressed on a ten point scale, with 10 representing the least attenuation (better).

We also used the frequency sweeps to study the effects of diaphragm pressure on the transfer function. (the tunable diaphragm effect). Light pressure was 50 grams, firm pressure was 240 grams. Frequency sweeps were done from 60-1000 HZ, to avoid damage to the transducer (At sine wave frequencies below 40 HZ the transducer was clipping in our test setup). The tunable diaphragm effect was also studied by recording heart sounds in our volunteers for 10 seconds under light pressure, and 10 seconds under firm pressure.

Stethoscope Model	Intensity Of Murmur	Clarity	Score
<u>Littmann Cardiology III</u>	7.8	5.0	13.0
<u>Littmann Master Classic II</u>	8.7	6.8	14.5
<u>Littmann Classic II SE</u>	5.3	7.1	16.4
<u>Omron Sprague Rappaport</u>	7.1	7.6	16.3
<u>Prestige Sprague Rappaport Stealth</u>	4.8	3.8	8.9

REFERENCES

- [1] *Digital Signals - Sampling and Quantization*. (n.d.). Retrieved October 22, 2011, from Robin Schmidt's Music Engineering Tools: <http://www.rs-met.com/documents/tutorials/DigitalSignals.pdf>
- [2] Gomez, R. (2009). *PowerWise Class G versus Class AB Headphone Amplifiers*. Retrieved 22 October, 2011, from National Semiconductor: http://www.national.com/assets/en/appnotes/national_sp_design_er118.pdf
- [4] Leyden, J. (2001, May/June). The Chance Invention that Changed Medicine. *Saturday Evening Post*, pp. 46-73.
- [5] Standris Medical Supply, Inc. (2011). *History of Stethoscopes*. Retrieved October 23, 2011, from Standris Medical Supply, Inc.: http://www.standris.com/education_history.cfm
- [6] Lambe, M. (2009, October 27). *How Does the Stethoscope Work*. Retrieved October 23, 2011, from Livestrong.com: <http://www.livestrong.com/article/30071-stethoscope-work/>
- [7] Grenier, M.-C., Gagnon, K., Genest Jr., J., Durand, J., & Durand, L.-G. (1998, March 1). Clinical Comparison of Acoustic and Electronic Stethoscopes and Design of a New Electronic Stethoscope. *The American Journal of Cardiology*, pp. 653-656.
- [8] Griffiths, D. J. (2008, September 26). *Development of Ionic Polymer Metallic Composites as Sensors*. Retrieved October 23, 2011, from www.docstoc.com/docs/6678426/David_J_Griffiths_MS_ME_Thesispdf
- [9] Birrenkott, D., Wendorff, B., Ness, J., & Durante, C. (2011). *Heart & Breath Sounds Amplifier*. Madison: University of Wisconsin-Madison Department of Biomedical Engineering.
- [10] *Mediacollege.com*. (n.d.). Retrieved October 21, 2011, from www.mediacollege.com/audio/microphones/condenser.html
- [11] Optoacoustics. (2011). *Technology: Core Sensor Platform*. Retrieved October 22, 2011, from Optoacoustics: <http://www.optoacoustics.com/technology/core-sensor-platform>
- [12] Analog Devices. (2011). *ADMP401: Omnidirectional Microphone with Bottom Port and Analog Output*. Retrieved October 15, 2011, from Analog Devices: <http://www.analog.com/en/audiovideo-products/imems-microphone/admp401/products/product.html>
- [13] Texas Instruments. (2011). *Wireless Connectivity Solutions: Bluetooth Technology*. Retrieved October 23, 2011, from Texas Instruments: http://focus.ti.com/general/docs/wtbu/wtbugencontent.tsp?templateId=6123&naviga tionId=12019&contentId=4635&DCMP=D_WTBU_WTBW_TBU&CMP=KNC-GoogleTI&247SEM University of Wisconsin Madison: Department of Biomedical Engineering
- Electronic Stethoscope** [14] Texas Instruments. (2011). *PurePath Wireless Audio*. Retrieved October 23, 2011, from Texas Instruments: <http://www.ti.com/ww/en/analog/cc8520/index.shtml?DCMP=>

A_Signal%20Chain_CC8 20%20PurePath&CMP=KNC-GoogleTI&247SEM

[15] <http://www.ti.com> Application Report SPRAB38A–June 2010 Digital Stethoscope Implementation on the TMS320C5515 DSP Medical Development Kit (MDK)
By Vishal Markandey

