



Weakly-Supervised Deep Embedding for customer Feedback Sentiment Analysis

¹Pradeepthi Gajula, ²N.Naveen Kumar

¹Student, ²Associate professor

¹Software Engineering,

¹School of Information Technology, Hyderabad, India

Abstract: The E-commerce business levels are every day rising, people are getting adopted to using on the web and composing remarks about their buy encounters on seller/audit Websites. These obstinate substances are gainful to both future purchasers for essential initiative and to sellers to enhance their products and moreover organization. To lighten this issue, numerous data mining approaches are designed which uses human efforts. Today, deep learning has risen as a powerful method for classification problems. We propound new deep learning system WDE that could use the huge amount of pitifully sorted audit reviews for the sentiment analysis. WDE attempts to catch the assessment circulation of the information by inserting preparing on pitifully marked sentences. At that point, it utilizes a couple of marked sentences for profound system adjusting just as for forecast model learning. In this system first, we train the data by CNN-WDE Classifier and then view the features vector. After that Detect the Sentimental labels. Then perform the classification and we can get the exact positive or negative view in the Sentiment Prediction Graph. To assess proposed framework, we took a dataset containing unlabeled reviews from Amazon.

Index Terms - Deep learning Weak-Supervision, Opinion Mining, Classification, Sentiment Analysis

I. INTRODUCTION

The E-commerce business levels are every day rising, people are getting adopted to using on the web and composing remarks about their buy encounters on seller/audit Websites. These obstinate substances are gainful to both future purchasers for essential initiative and to sellers to improve their products. Be that as it may, as the volume of surveys develops quickly, individuals need to confront a serious data over-burden issue. To lighten this issue, numerous feeling mining procedures have been proposed, for example assessment synopsis conclusion surveying, and relative examination. The key test is the manner by which to precisely anticipate the estimation introduction of survey sentences. Notable opinion grouping strategies are apportioned into 2 classes: dictionary-based techniques and Machine Learning. The Dictionary-based procedure normally takes the tack of the first structure an estimation dictionary of opinion words (for example "wonderful", "disgusting"), and after that structure arrangement rules dependent on showed up assessment words and earlier syntactic information. Regardless of adequacy, these sorts of strategies require significant endeavors in vocabulary development and standard structure. Besides, dictionary-based techniques can't deal with verifiable conclusions, for example, target proclamations, for example, "I purchased the cushions nine days back, what's more, a valley showed up today". As pointed out in, this is likewise an essential type of feelings. Authentic data is normally more helpful than subjective feelings.

We propound new deep learning system WDE that could use the huge amount of pitifully sorted audit reviews for the sentiment analysis. This structure attempts to catch the assessment circulation of the information by inserting preparing on pitifully marked sentences. At that point, it utilizes a couple of marked sentences for profound system adjusting just as for forecast model learning. We come up with neural specification for WDE and start-up with well-known neural system plans for demonstrating information: CNN and LSTM

1.1 EXISTING SYSTEM

Over ongoing days deep learning is determined as emphatic method for sentiment classification problems. Deep learning intensely depends on the possibility of large training data set which involves huge human efforts.

1.1.1 DISADVANTAGES OF EXISTING SYSTEM

There is no past work attempted to use the prominently accessible ratings for training data models.

1.2 PROPOSED SYSTEM

The framework classifies the review sentences into groups. It concedes ratings as weakly labeled for training the deep neural networks. The framework makes familiar with an embedding space that mirrors general opinion conveyance of sentences, from an enormous weakly named sentence. We drive sentences with the equivalent weak sentences that close to one another, while sentences which have weak labels are avoided. To classify the review, the classification layer is included at head of the model.

1.2.1 Advantages of Proposed system

- The propound framework is effective.
- Eliminates laborious work.
- Feasible to use.

II. SYSTEM REQUIREMENTS

2.1 HARDWARE REQUIREMENTS

- Processor : Core – i5
- RAM : 256 MB
- Hard Disk : 20GB

2.2 SOFTWARE REQUIREMENTS

- Coding Language : Java
- IDE : Eclipse
- Operating System : Windows 10

III. RELATED WORK

Sentiment Classification using Deep learning [1]

Deep learning has risen as an incredible AI strategy that learns numerous layers of portrayals or highlights of the information and produces cutting edge expectation results. Alongside the achievement of deep learning in numerous other application areas, deep learning is additionally famously utilized in sentiment analysis as of late. Deep learning has developed as an amazing AI method and delivered best in class brings about numerous application areas, extending from PC vision and discourse acknowledgment to NLP. Applying deep learning out how to feeling examination has likewise become exceptionally mainstream.

Grouping for Concurrent Extraction of Aspects and Features from Audits [2]

Clustering approach identifies item highlights and gatherings them into aspect classes from online feedbacks. Dissimilar to earlier methodologies that first extract features and afterwards grouped according to classifications, the proposed approach consolidates feature extraction and perspective disclosure as opposed to anchoring them. Furthermore, earlier work on feature extraction requires seed terms and spotlight on distinguishing unequivocal highlights, while the proposed approach separates certain features, and doesn't require seed terms. We assess this methodology on audits from three areas. The outcome shows that it outflanks a few best in class strategy children the two undertakings over each of the three areas techniques.

Deep Memory Model Network for Aspect Sentiment Analysis

'Deep memory model is for aspect level analysis'. Not at all like element based SVM and successive neural models, for example, LSTM, this methodology expressly catches the significance of every setting word while inducing the feeling extremity of a viewpoint. Such significance degree text is determined with various computational stage every stage is a neural consideration model over a memory. Investigations on PC and eatery datasets show that our methodology performs similarly to condition-of-craftsmanship include based SVM framework, and considerably better than LSTM and consideration based LSTM models. On both datasets, we show that various computational layers could improve the exhibition. Additionally, our methodology is likewise quick. The deep network coordinate with 9 layers is multiple times quicker than LSTM with a CPU execution.

IV. PRODUCT DESIGN

A. UML DIAGRAMS:

4.1 Class Diagram

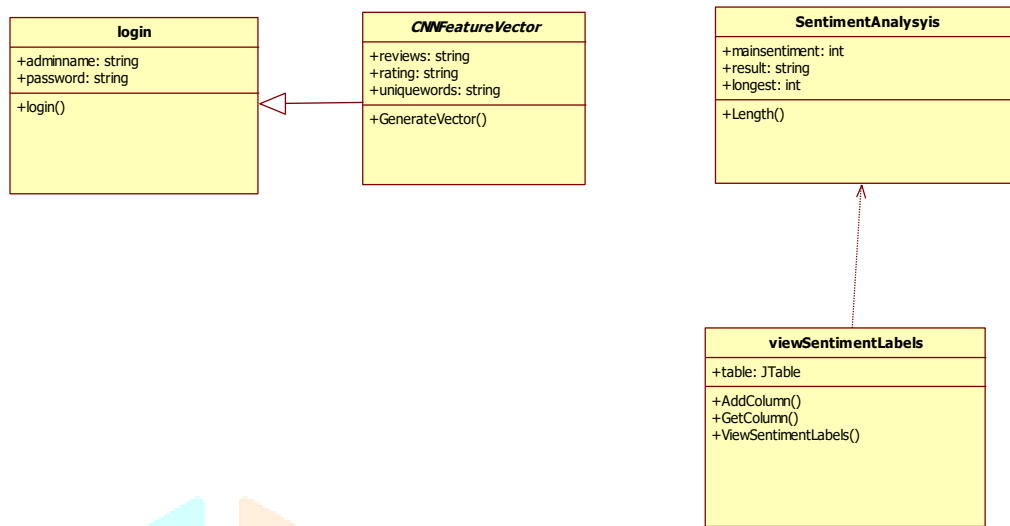

Fig -1: Class diagram

4.2 Dataflow Diagram

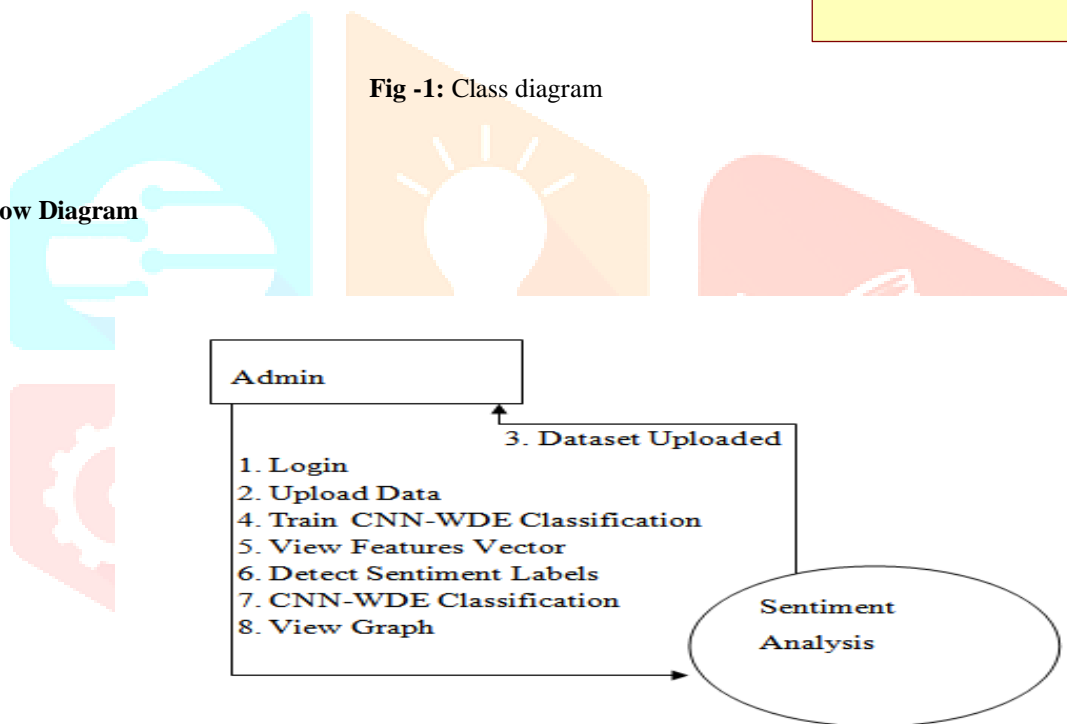

Fig -2: Dataflow diagram

B. MODEL ARCHITECTURE

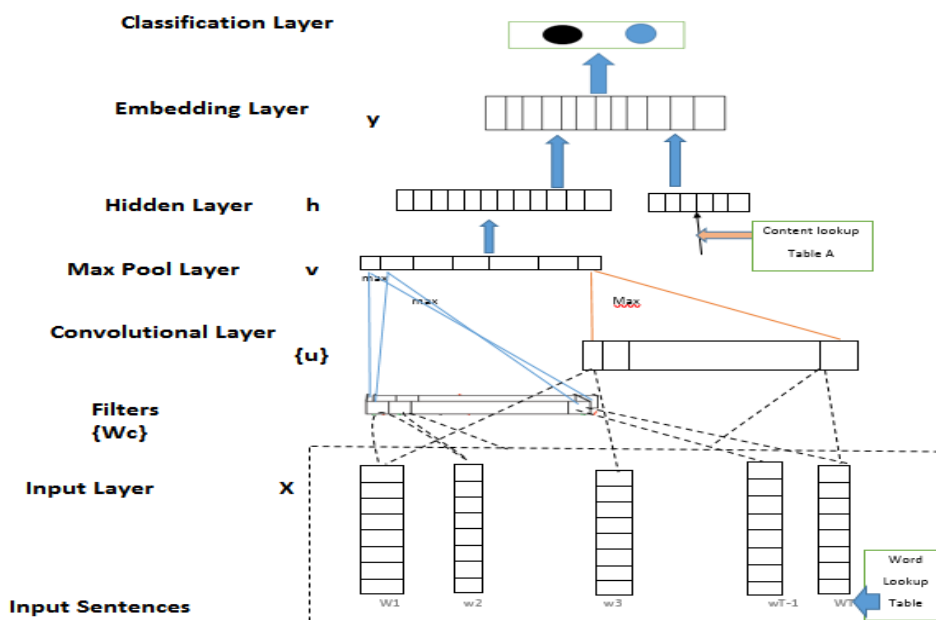

Fig -3: Model Architecture

V. Network Architecture of WDE-CNN

In our architecture matrices is denoted by bold letter 'W' and column is denoted by small letter 'x'. $x(i)$ is used to specify i-th element in 'x'.

Input Layer

It holds the input sentence of the word sequence $s = \langle w_1 w_2 w_3 w_4 : : w_T \rangle$ where w is depicted using word vector x . The Input Layer basically maps $s = \langle w_1 w_2 w_3 w_4 : : w_T \rangle$ to its comparing word vector portrayal $\langle x_1 x_2 x_3 x_4 : : x_T \rangle$.

Convolutional Layer and Max Pooling Layer

A convolutional layer inside a neural framework should have the going with characteristics:

- Convolutional portions described by width and height (hyper-limits).
- The significance of the Convolution channels must be identical to the quantity of channels. It comprises of numerous channels to apply on the sentences.

Pooling

A pooling layer is a structure square of a Convolutional Neural Network. Max pooling technique is used in pooling stage. In max pooling maximum value is selected and remaining will be discarded.

Hidden Layer and Embedding Layer

The fully connected hidden layer takes the feature vector v and embedding layer to remove nonlinear more significant level features. The embedding layer takes commitment from two sources: the yield of the hidden layer h , and setting vector as of sentences.

Classification Layer

Classification layer is completely associated with the embedding layer and yields sentiment prediction for the info sentence. classification is performed dependent on the features extracted by the convolutions.

VI. TESTING AND RESULTS

Software testing consists of activities (stimuli and observations) to determine whether given grouping is acceptable or not and respond with a pass or fail decision on the worthiness of any test arrangement for which it is characterized. Testing is a form of verification. In verification, an implementation is examining the coherence of a given specification. The correctness of the implementation can be checked by executing the test case

Following are the testing strategies followed during the test period:

TEST CASES:

Test Case Id	Test Case Name	Test Case Description.	Test Steps			Status	Priority
			Step	Expected	Actual		
01	Admin Login	Verify the either admin is valid or not	Without Authentication	Admin cannot login	Open Home page to valid admin	High	High
02	Upload Dataset	Test whether the Dataset is uploaded or not into the system	If Dataset may not uploaded	We cannot perform training	Chosen Dataset uploaded	Medium	Medium
03	Train CNN-WDE Classifier	Verify either the Dataset Trained or not	Without uploading dataset	We cannot perform the classification	The data trained by the CNN-WDE classifier successfully	High	High
04	View feature vector	Test the features vectors are visible or not	Without trained data	We cannot view data without trained	The features of vectors are successfully visible	High	High

05	Detect Sentiment Labels	Test whether the Sentiment labels are detected or not	If the vectors are not visible	User cannot detect the sentiment labels	User can Detect Sentiment Labels	High	High
06	CNN-WDE Classification	Verify the Classification performed or not	Sentiment labels are not detected	Then the classification is not performed	We can perform the Classification	High	High
07	Sentiment prediction graph	Verify the positive reviews and negative reviews	The classification may not performed	positive and negative reviews are not displayed	We can see the positive and negative reviews successfully	High	High

Table -1: Test cases

RESULTS:

To experiment with our model, I took the reviews from Amazon site

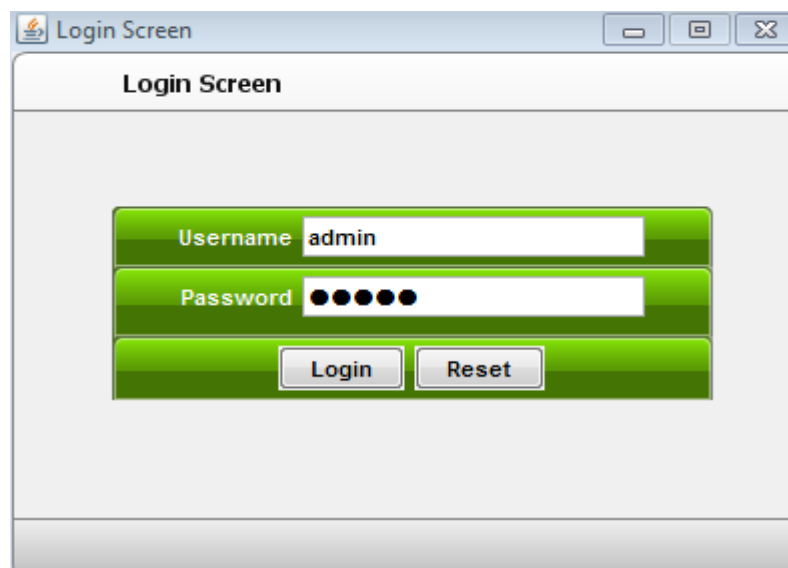

Fig -4: login screen

After login we get below screen

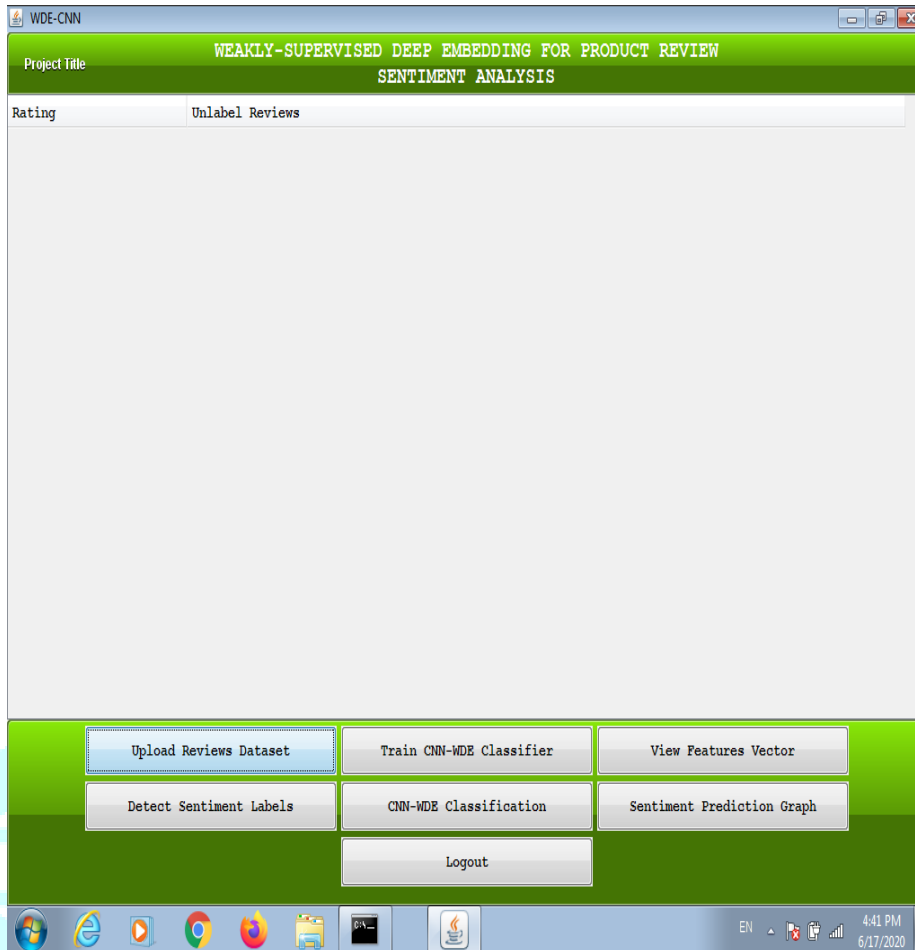

Fig -5: Home screen

Now click on 'Upload Reviews Dataset' button to upload dataset.

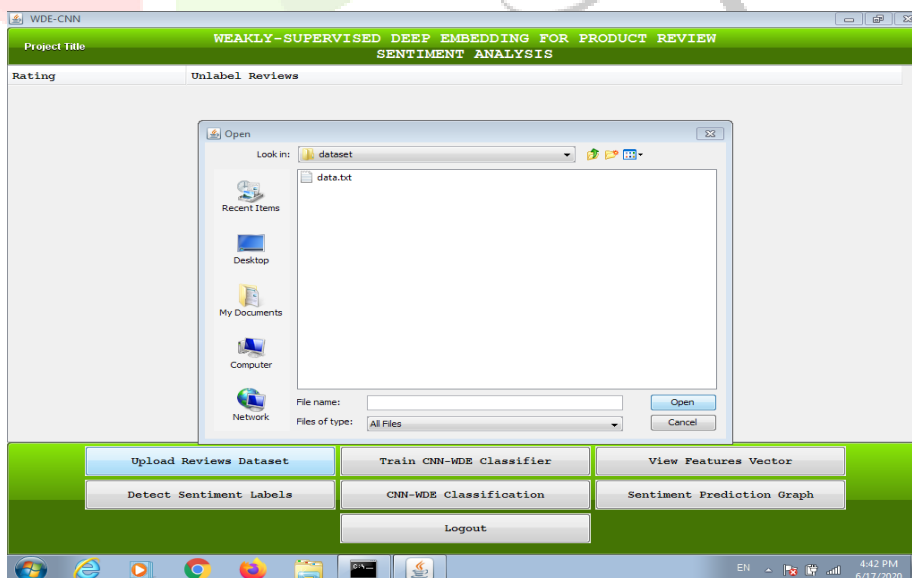

Fig -6: Upload screen

Will get below screen after dataset is uploaded

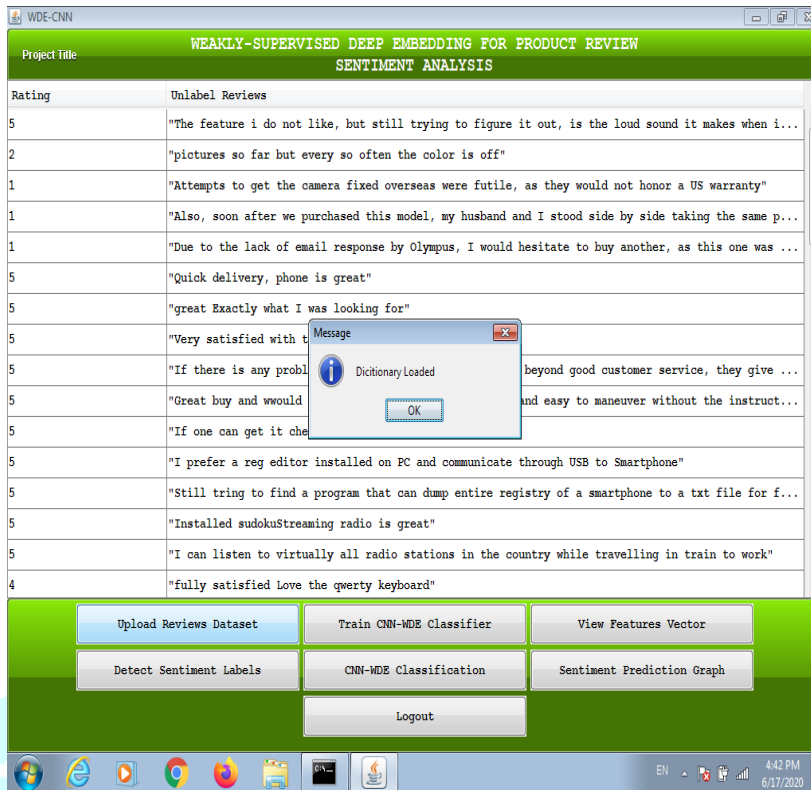

Fig -7:Dataset uploaded

In first column review rating and in second column review text is there. Now click on 'Train CNN-WDE Classifier' to train dataset using CNN-WDE algorithm

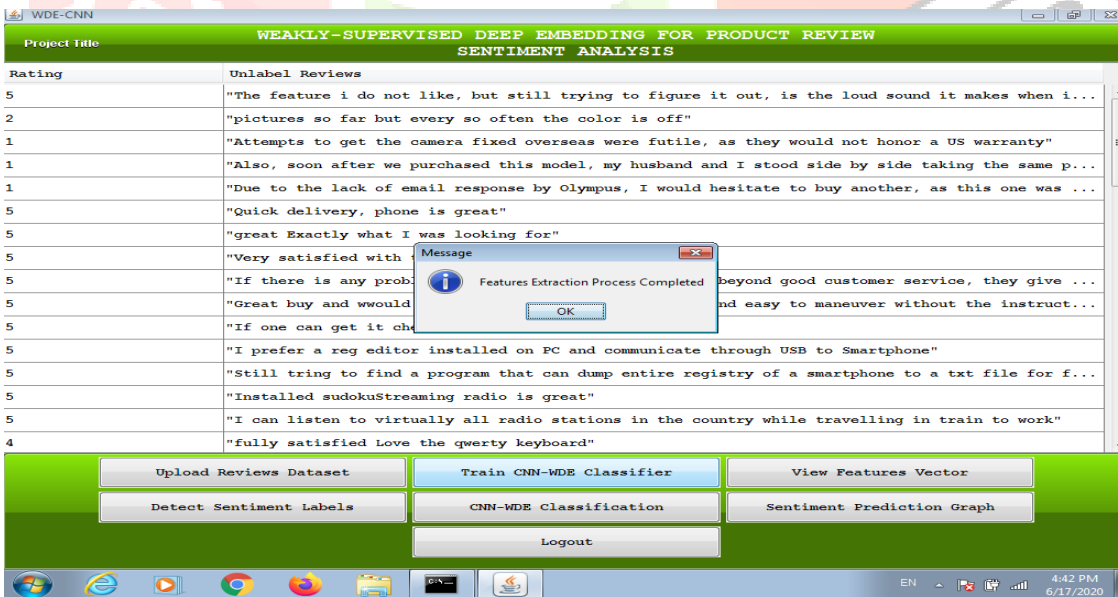
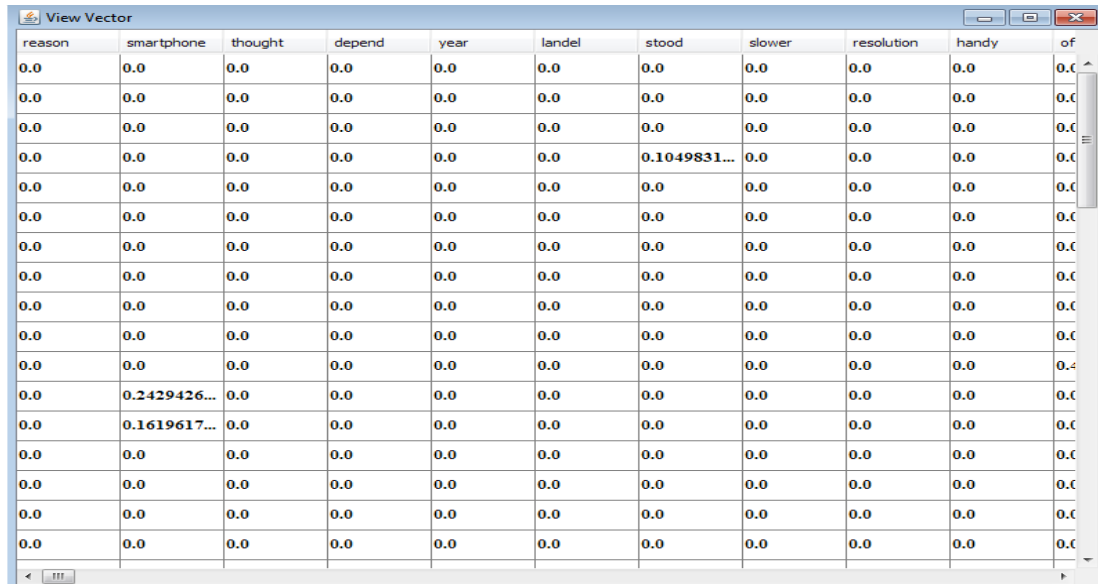

Fig -8: Train CNN-WDE Classifier

Now click on 'View Features Button' to view extracted features



reason	smartphone	thought	depend	year	landel	stood	slower	resolution	handy	of
0.0	0.0	0.0	0.0	0.0	0.0	0.0	0.0	0.0	0.0	0.0
0.0	0.0	0.0	0.0	0.0	0.0	0.0	0.0	0.0	0.0	0.0
0.0	0.0	0.0	0.0	0.0	0.0	0.0	0.0	0.0	0.0	0.0
0.0	0.0	0.0	0.0	0.0	0.0	0.1049831...	0.0	0.0	0.0	0.0
0.0	0.0	0.0	0.0	0.0	0.0	0.0	0.0	0.0	0.0	0.0
0.0	0.0	0.0	0.0	0.0	0.0	0.0	0.0	0.0	0.0	0.0
0.0	0.0	0.0	0.0	0.0	0.0	0.0	0.0	0.0	0.0	0.0
0.0	0.0	0.0	0.0	0.0	0.0	0.0	0.0	0.0	0.0	0.0
0.0	0.0	0.0	0.0	0.0	0.0	0.0	0.0	0.0	0.0	0.0
0.0	0.0	0.0	0.0	0.0	0.0	0.0	0.0	0.0	0.0	0.0
0.0	0.0	0.0	0.0	0.0	0.0	0.0	0.0	0.0	0.0	0.0
0.0	0.2429426...	0.0	0.0	0.0	0.0	0.0	0.0	0.0	0.0	0.0
0.0	0.1619617...	0.0	0.0	0.0	0.0	0.0	0.0	0.0	0.0	0.0
0.0	0.0	0.0	0.0	0.0	0.0	0.0	0.0	0.0	0.0	0.0
0.0	0.0	0.0	0.0	0.0	0.0	0.0	0.0	0.0	0.0	0.0
0.0	0.0	0.0	0.0	0.0	0.0	0.0	0.0	0.0	0.0	0.0
0.0	0.0	0.0	0.0	0.0	0.0	0.0	0.0	0.0	0.0	0.0
0.0	0.0	0.0	0.0	0.0	0.0	0.0	0.0	0.0	0.0	0.0

Fig -9: Feature Vector Screen

Now click on 'Detect Sentiment Labels' to detect either review is positive or negative

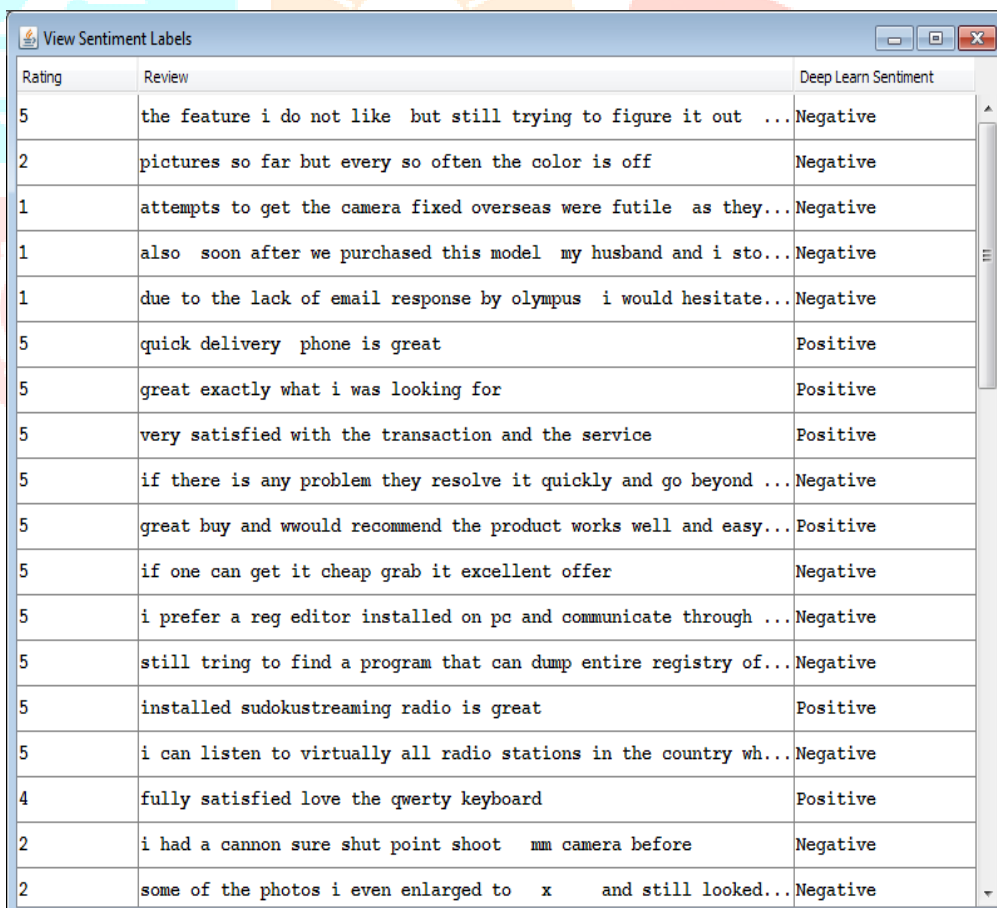

Rating	Review	Deep Learn Sentiment
5	the feature i do not like but still trying to figure it out ...	Negative
2	pictures so far but every so often the color is off	Negative
1	attempts to get the camera fixed overseas were futile as they...	Negative
1	also soon after we purchased this model my husband and i sto...	Negative
1	due to the lack of email response by olympus i would hesitate...	Negative
5	quick delivery phone is great	Positive
5	great exactly what i was looking for	Positive
5	very satisfied with the transaction and the service	Positive
5	if there is any problem they resolve it quickly and go beyond ...	Negative
5	great buy and would recommend the product works well and easy...	Positive
5	if one can get it cheap grab it excellent offer	Negative
5	i prefer a reg editor installed on pc and communicate through ...	Negative
5	still try to find a program that can dump entire registry of...	Negative
5	installed sudokustreaming radio is great	Positive
5	i can listen to virtually all radio stations in the country wh...	Negative
4	fully satisfied love the qwerty keyboard	Positive
2	i had a cannon sure shut point shoot mm camera before	Negative
2	some of the photos i even enlarged to x and still looked...	Negative

Fig -10: Sentiment Labels

In the above first column is ratings, second column is reviews and third column is classification.

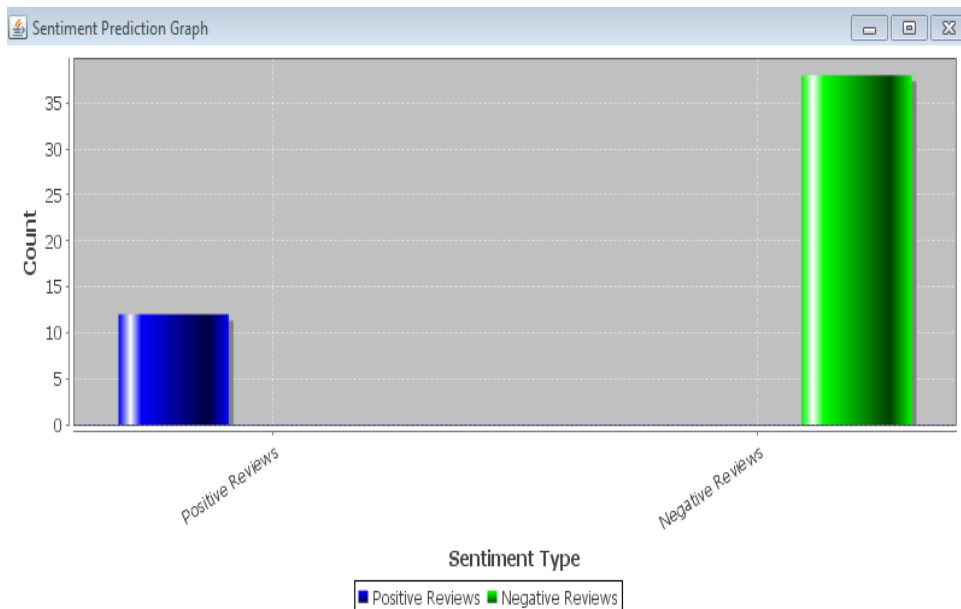

Fig -11: Sentiment Prediction Graph

Positive feedback and negative feedback are represented in X-axis. The number of reviews count is represented in Y-axis.

Input is given for classification

Rating	Unlabel Reviews
5	"The feature i do not like, but still trying to figure it out, is the loud sound it makes when i..."
2	"pictures so far but every so often the color is off"
1	"Attempts to get the camera fixed overseas were futile, as they would not honor a US warranty"
1	"Also, soon after we purchased this model, my husband and I stood side by side taking the same p..."
1	"Due to the lack of email response by Olympus, I would hesitate to buy another, as this one was ..."
5	"Quick delivery, phone is great"
5	"great Exactly what I was looking for"
5	"Very satisfied with the purchase"
5	"If there is any problem with the phone, they provide good customer service, they give ..."
5	"Great buy and would recommend to others"
5	"If one can get it, it's a great phone"
5	"I prefer a reg editor installed on PC and communicate through USB to Smartphone"
5	"Still trying to find a program that can dump entire registry of a smartphone to a txt file for f..."
5	"Installed sudokuStreaming radio is great"
5	"I can listen to virtually all radio stations in the country while travelling in train to work"
4	"fully satisfied Love the qwerty keyboard"

Fig -12: CNN-WDE Classification

Project Title	
WEAKLY-SUPERVISED DEEP EMBEDDING FOR PRODUCT REVIEW SENTIMENT ANALYSIS	
Rating	Unlabel Reviews
5	"The feature i do not like, but still trying to figure it out, is the loud sound i
2	"pictures so far but every so often the color is off"
1	"Attempts to get the camera fixed overseas were futile, as they would not honor a
1	"Also, soon after we purchased this model, my husband and I stood side by side tak
1	"Due to the lack of email response by Olympus, I would hesitate to buy another, as
5	"Quick delivery, phone is great"
5	"great Exactly what I was looking for"
5	"Very satisfied with t
5	"If there is any probl
5	"Great buy and wwould
5	"If one can get it che
5	"I prefer a reg editor installed on PC and communicate through USB to Smartphone"
5	"Still tring to find a program that can dump entire registry of a smartphone to a
5	"Installed sudokuStreaming radio is great"
5	"I can listen to virtually all radio stations in the country while travelling in t
4	"fully satisfied Love the qerty keyboard"

Message

Given review classified as : Positive

OK

Upload Reviews Dataset
Train CNN-WDE Classifier
View Features Vect

Fig -13: Classification message

Now in above screen we can see, the given input is identified as positive.

VI CONCLUSION

We propound a deep learning model named "Weakly-supervised Deep Embedding for sentiment classification of review sentence." WDE gets ready deep neural model uses rating and audit for classification. This data is inescapably open on different web based business Websites. This model comprises of two phases. To begin with, we gain capability with an embedding space which it gets the sentiments of sentences by relative divisions among sentences as demonstrated by week after week named audits; softmax classifier is incorporated head of the model and adjust the model by labeled information. Examinations on reviews assembled from Amazon show that WDE is fruitful and beats benchmark systems. By this strategy, we can classify positive or negative reviews.

REFERENCES

- [1] Y. Bengio. Learning deep architectures for AI. Foundations and trends R in Machine Learning, 2(1):1–127, 2009.
- [2] Y. Bengio, A. Courville, and P. Vincent. Representation learning: A review and new perspectives. IEEE TPAMI, 35(8):1798–1828, 2013.
- [3] Y. Wang, M. Huang, X. Zhu, and L. Zhao. Attention-based LSTM for aspect-level sentiment classification. In EMNLP, pages 606–615, 2016.
- [4] R. Socher, B. Huval, C. D. Manning, and A. Y. Ng. Semantic compositionality through recursive matrix-vector spaces. In EMNLP-CoNLL, pages 1201–1211, 2012.
- [5] R. Socher, J. Pennington, E. H. Huang, A. Y. Ng, and C. D. Manning. Semi-supervised recursive auto encoders for predicting sentiment distributions. In EMNLP, pages 151–161, 2011.