



DEVELOPMENT AND IMPLEMENTATION OF UNDER WATER COMMUNICATION USING IoT

¹Mr.Puneeth U O,²Ms.Suvaratha,³Ms.Hamsashree. G, ⁴Ms. Vandya. M,⁵Mr.Pavan kumar E

¹Student,² Student,³Student ,⁴Student ,⁵Professor

¹Electronics and Communication Engineering,

¹Sai Vidya Institute of Technology, Bangalore,India

Abstract: Occurrence in wireless tool and technologies, Underwater Wireless Sensor Networks (UWSN) are undergoing dynamic occurrence. In UWSNs, long established many node information collections has different drawbacks, such as Excessive-power utilization and wireless information communication. In recent years, on-board mobile components (such as the underwater autonomous vehicle) have been used extensively for oceanographic information collection to address imbalances in energy utilization. Still, present techniques do not completely take into account systematic mobile evaluating and the true AUV mobility type in the underwater environment. In this project, we offer a information gathering scheme based on the mobility type of oceanographic peripheral mobile components. In this type, the direction and speed of mobility are completely taken into account, which is nearly similar to the development behaviour of the AUVs in a secure 3D nature. Utilizing the processing, storage and mobility power of United AUV, the target selection algorithm is fabricated to predict the track of improvement in information gathering for AUV. Conceptual analysis and practical results exhibit that the advanced method improves the efficiency of information gathering, reduces the energy utilization of the nodes and increases the useful life of the network.

Keywords—Underwater Communication, Underwater wireless sensor networks, Autonomous underwater vehicle. Edge computing,3D environment, Wireless information communication, long established multi-hop information collection.

I. INTRODUCTION

Lately, the IoT (Internet of Things) are progressively put in different fields, for example, shrewd home, savvy city, smart shipment, natural checking, security frameworks, and propelled fabricating. The IoT is made out of innovations, for example, arrange edge gadgets (cell phones) and remote advances. With quick advancements in cell phones and remote innovations, cell phones and portable applications assume an inexorably significant job in everyday life and give extraordinary potential improvements to Mobile Edge Computing (MEC). Portable edge processing is a figuring worldview to execute the distributed computing administrations on arranging edges, utilizing versatile edge gadgets, for example, doors, switches, miniaturized scale servers. Versatile edge gadgets have favorable circumstances away, portability and figuring, which are near the edge of the system. Consequently, MEC can offer quicker support reactions and lessen the system clog in the IoT.

Correspondingly, with advancements of submerged IoT and cell phones, for example, acoustic sensors, and AUV. UWSNs are generally utilized in sea asset identification, submerged condition observing, and helper route. The UWSNs is a submerged observing system framework, which is made out of numerous sensor hubs with correspondence, information assortment and figuring abilities.

Information assortment is a significant research field in the UWSNs and can be treated as a portable edge application. Present-day submerged implementation produce gigantic information, for example, top quality video, sound, and images. For lengthy separation transference by remote sign in UWSNs, the gathered information is anything but difficult to lose. The information gathered by sensor hubs should be transmitted to the accepting hub, and it advances through multi-jump steering, which devours a great deal of vitality. Besides, this is hard to optimize the cell (Battery) of the submerged portable edge components. Consequently, how to decrease the vitality utilization of hubs and how to improve the correspondence between two hubs and hubs with AUV's submerged has become an urgent issue.

II. OBJECTIVES

The main objectives of this project are as per the following:

1. We join magnetic induction (MI) interchanges with acoustic correspondences to transmit information, which can decrease the information circulation time viably.
2. We offer another information assortment conspire dependent on a versatility type of portable edge components under the submerged sensor systems.
3. We use AUV as the portable edge processing surface, giving the versatile edge registering, information assortment administration and We give the sun-oriented board to AUV to energize its battery when it turned out to be low.
4. We offer an objective hubs determination calculation dependent on the versatile edge type, which empowers the Vehicle to overtake all hubs in the briefest time, parity vitality utilization of the entire web.

III. RELATED WORKS

- A Special Section Editorial of IEEE Access: Underwater Wireless Communications in underwater and networking [1] in this paper them discuss about how Play out a direction alteration system to defeat the "hot region's" issue and equalization the heap of the hubs to drag out system lifetime. In this drawback is the normal postponement of this plan is bigger than that of other conventions.
Underwater Magnetic Induction Communication Survey: Fundamental Issues, Recent and further Challenges [2]. The strength of this will wipe out the hindrances of Acoustic interchanges and Optical correspondences. Drawback is more crosstalk in sensor arrange.
- An Energy-Efficient Routing Algorithm for Underwater Wireless Optical Sensor Web [3]. They discuss about the vitality control impacts significantly on the exhibition of steering in a submerged correspondence organize. DEEB calculation can fundamentally diminish the directing utilization of vitality. Drawback is when the battery charge is over the system will be in off state.
- An Inspired Underwater Communication Robotic Fish for Aquatic Animals [4]. In this offer framework has high portability intrinsically, it covers a huge working zone with a modest number of moving hubs. Drawback is hard to build up multi-jump arrange correspondence.
- Localization and noticing of Targets in Underwater Wireless Sensor Using Distance and Angle Based Algorithms [6]. The strength of this is present two new calculations for restriction, specifically separation based and edge-based confinement calculations. Drawback is with respect to offer separation based and edge based restriction calculations the mistake is more and it must improve for $D > 2$.

IV. IMPLEMENTATION



Figure (1): Creating of wireless sensor web

N1 → Node 1 → containing interfacing BMP 180 with ESP32

N2 → Node 2 → containing interfacing DH11 with ESP32

N3 → Node 3 → containing interfacing ADXL335 with ESP32

Interfacing BMP 180 with ESP32

Interfacing of the BMP180 barometric sensor with the ESP32 and using the web server shows the sensor's respect on the website page. BMP180 sensor is used to calculate temperature, weight and height. With this sensor we can measure the pressure level and the actual height.

In this exercise we will look at the following focus:

- Connection chart of BMP180 with ESP32
- How to introduce BMP180's library in Arduino IDE?
- Temperature How to estimate temperature, weight and height?
- What way to show sensor respect on a web server?

Table below above the pin out of BMP180 sensor. It performs I2C communication protocol.

Pins	Function
Vin (Power supply pin)	Connect 3.3 volts to this pin
GND	GND pin of power supply
SCL (I2C clock pin)	Connect with SCL pin of any microcontroller
SDA (I2C information pin)	Connect with SDA pin of any microcontroller

Table (1): PIN function of BMP180

BMP180 Connection Diagram with ESP32

- Given create a sensor attachment with ESP32 are provided by given below.
- Round associate the GND pin and 3.3 volts pin to the ESP32 individually with the ground and the BMP180's Vin pin.
- ESP32 supports I2C correspondence. GPIO22 and GPIO21 are related to I2C correspondence. You can influence the ESP32 pinout for additional subtleties.
- GPIO22 is a SCL pin and GPIO21 is the SDA pin for this DEVKIT DOIT panel. So these pins can be fitted in different areas for individual class of panels. Along these lines, you should check the pinout of your board.

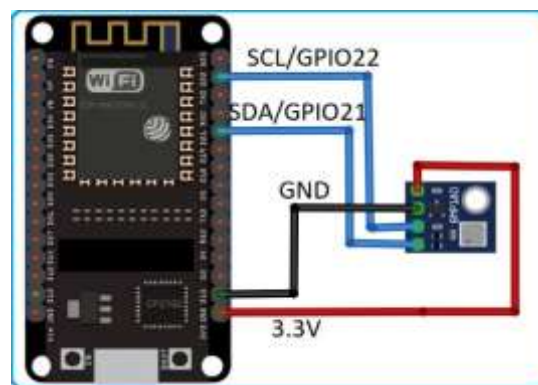

Figure (2): Interfacing circuit of BMP 180 with ESP32

Interfacing DHT11 Humidity temperature sensor with ESP32

The DHT11 (or DHT22 and comparable) are modest temperature and moistness sensors. The speak with an ESP32 is over a solitary wire, yet tragically it isn't good with the 1-Wire convention characterized by Dallas Semiconductors. The electric association with the ESP32 Devkit is straightforward, as the DHT arrangement can be controlled directly with 3.3V. Just 3 wires are required: VCC, GND and the information line. Information Line is associated with GPIO15 (D15).

DHT11 Connections with ESP32

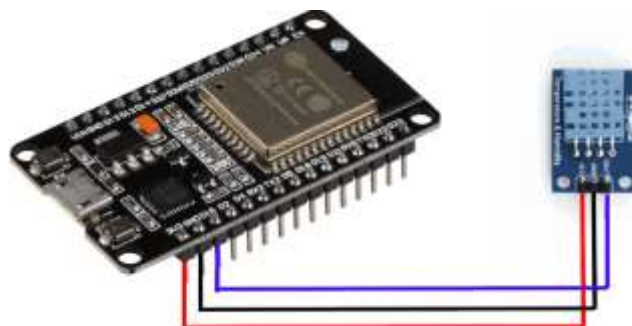

Figure (3): Interfacing circuit of DHT11 Humidity temperature sensor with ESP32

Interfacing of ADXL335 with ESP32

The ADXL335 is a 3-axis analog accelerometer that generates raw X, Y and Z axis data on 3 keys. So, connect these to the analog input pins in the Explorer M3 and log the information to the sequential monitor.

EARTHQUAKE / SEISMIC TREMOR INDICATOR USING ARDUINO

A seismic tremor is impossible to avoid and flighty often breakages live and property. We can't quarrel it, still we can be conscious and mindful utilizing innovation that can safety us and the business. Presented Here is a common home and industry utilizing an Arduino and exceptionally touchy ADXL335 (Fig. 1) accelerometer is introduced it can show vibrations. Fundamental point is to differentiation in the middle of tremors and other seismic exercises.

We realize that accelerometers like ADXL335 are profoundly touchy to thumps and vibrations in any of the three physical tomahawks. ADXL335 provides phase to neutral voltage proportional to forced acceleration. It has three results, one each for of X-, Y-and Z-tools. The three simple results are wired to Arduino Uno ADC pins. Any speeding up caused because of invention in any of the tomahawks is identified by the accelerometer and henceforth by Arduino ADC.

On the off chance that development is fierce enough during a tremor and crosses a specific edge, a nearby caution light (LED) shines, a signal sounds just as a hand-off invigorates. While the bell and light are for home reason, transfer yield is for modern reason; it very well may be wired to a PLC for security interlocking of any moving machine part and heater control for closing these down if there should arise an occurrence of a tremor. The limit change catches are there for completing this undertaking. An LCD has been accommodated seeing limit modifications and for making the framework easy to use.

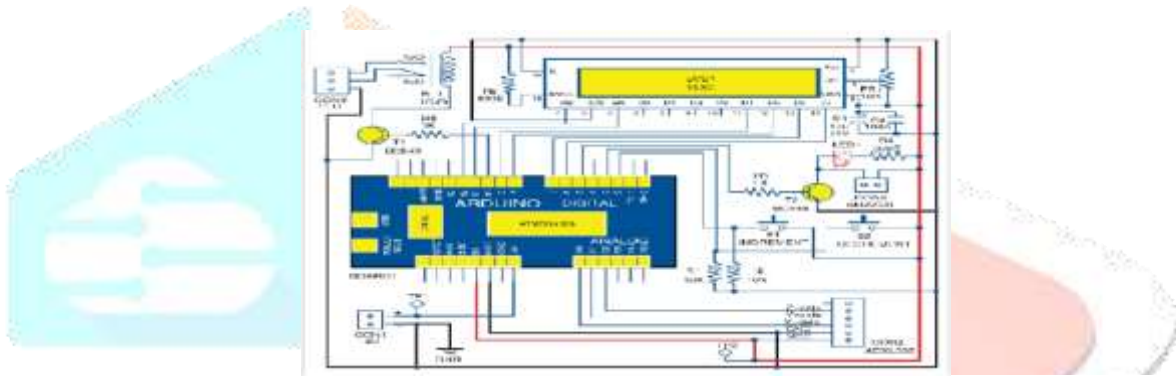

Figure (4): Circuit diagram of the earthquake indicator



Figure (5): Initializing mode

ESP8266 CLIENT AND SERVER WI-FI SERVICES IN THE MIDDLE OF TWO PANELS (NODEMCU)

Study how to demonstrate a Wi-Fi Services (HTTP) in the middle of two ESP8266 Node MCU panels to interchange information without the need to attach to the Network (you don't need a router).

We are moving to set one ESP8266 as an Access Point (Server) and other ESP8266 as a Station (Client). Then, the server and the client will interchange information (sensor readings) via HTTP requests. We will initiative the ESP8266 panels using Arduino IDE.

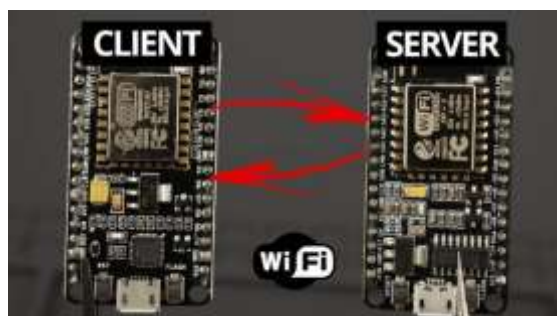

Figure (6): ESP8266 Client and Server Wi-Fi services in the middle of Two Panels

To better understand look at the following diagram.

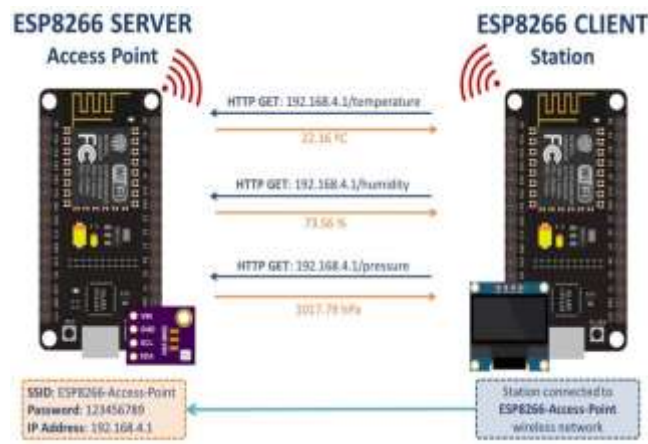

Figure (7): server address for HTTP access

- ESP8266 server make its own wireless web([ESP8266Soft-AccessPoint](#)).As a result of, other Wi-Fi tool can connect to that web(SSID: ESP8266-Access-Point,Password: 123456789).
- ESP8266 client is fix as a position. As a result of, it can equate to the ESP8266 server wireless web.
- Client can create HTTP GET appeal to the server to request sensor information or any other information. It just wants to use the IP address of the server to create a appeal on a precise route temperature, humidity, or pressure.
- Server listens for incoming appeals and sends an appropriate feedback with the readings.
- The client receives the readings and displays them on the OLED display.

For example, the ESP8266 client requests temperature, humidity and pressure to the server by assembling appeals on the server IP address followed by temperature, humidity and pressure, respectively (HTTPGET).

The ESP8266 server is hearing on those paths and when a petition is made, this sends the equivalent sensor solutions via HTTP feedback.

Information transfer between Raspberry Pi and ESP32

AUV consists of Raspberry Pi. ESP32 acting as an MQTT publisher, the Raspberry Pi acting as the MQTT Broker and also as a subscriber to then read the telemetry information and upload it to the cloud. A dashboard could then be written to display the relevant information and alarms.

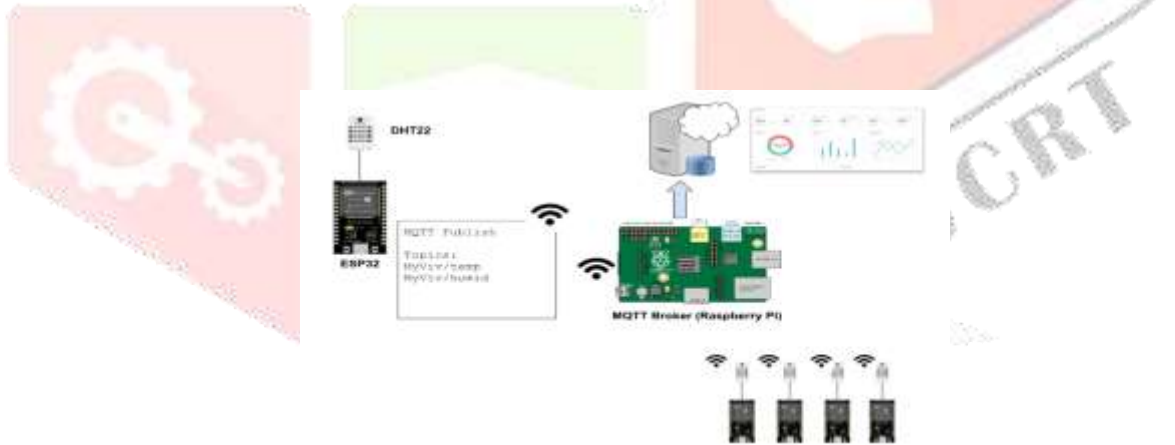

Figure (8): interfacing between ESP32 and Raspberry Pi

V. WORKING OF OUR TYPE



Wireless sensor web and AUV



The wireless sensor web start sharing the sensor information



Once the AUV comes near to the node it able to receive the sensor information as shown above figure.



If node 1 not able to send the sensor information to AUV, then it will send the information to the nearer node as shown in above figure.



Now AUV is move forward and nearer to the node 2



The node 2 is start sharing the sensor information to the AUV as shown in figure above.



If node 2 failed to send the sensor information to AUV, then it will send the information to the nearer node as shown in above figure.

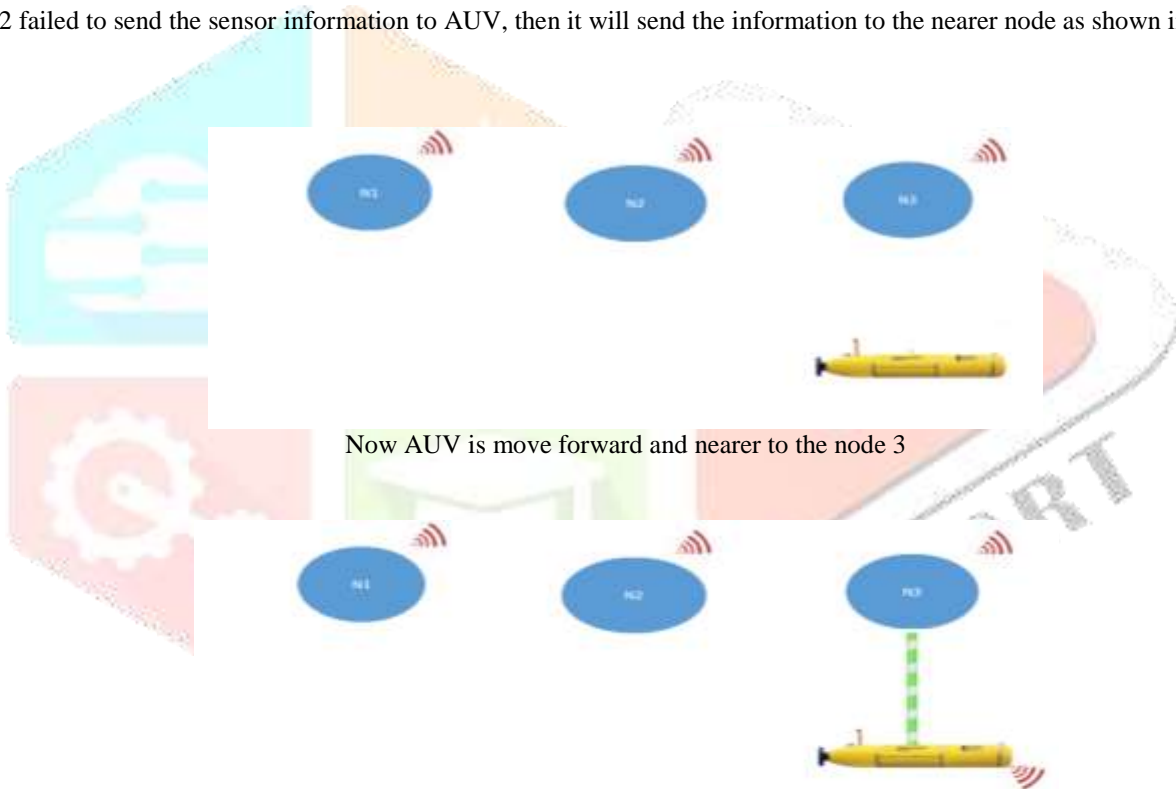

The node 3 is start sharing the sensor information to the AUV as shown in figure above.



After receiving the sensors information, the AUV will send the information to gateway, which is located surface of water.

VI. CONCLUSION

This project describes the design and implementation of an IoT based underwater Services vehicle. The goal of this project is to develop an underwater vehicle to have better Services between the nodes and the external world or the user.

Despite much invention in this area of underwater communication, the report gives an overall view of the necessity of underwater communication and its applications.

VII. REFERENCES

- [1] Yuh-Shyan Chen, Tong-Ying Juang, Yun-Wei Lin, I-Che Tsai A Low Propagation Delay Multi-Path Routing Protocol for Underwater Sensor Networks Journal of Internet Technology Volume 11 (2010) No.2.
- [2] ArturZolich,DavidPalma,KimmoKansanen,KayFjørtoft,JoãoSousa,KarlH.Johansson,YumingJiang,HefengDong,TorA.Johansen Survey on Communication and Networks for Autonomous Marine Systems.
- [3] JianZHAO, TingtingYANG, Hai LongFENG, Study on Wide-Band Communication at Sea Under E-Navigation Framework 2017 4th International Conference on Information, Cybernetics and Computational Social Systems (ICCS).
- [4] B. Pranitha, L. Anjaneyulu Review of Research Trends in Underwater Communications-A Technical Survey 978-1-5090-0396-9/16/\$31.00 ©2016 IEEE.
- [5] V.P. Dhviya,R. ArthiAnalysis of Simulation Tools for Underwater Wireless Sensor Networks International Journal of Computer Science & Engineering Technology (IJCSET) Vol. 5 No. 10 Oct 2014.
- [6] Raja Jurdak, Cristina Videira Lopes, Pierre Baldi Battery Lifetime Estimation and Optimization for Underwater Sensor Networks,Published in IEEE Sensor Network Operations.
- [7] C. Namesh,Dr. B. Ramakrishnan. Analysis of VBF protocol in Underwater Sensor Network for Static and Moving Nodes, International Journal of Computer Networks and Applications Volume 2, Issue 1, January - February (2015).
- [8] Subha M, Sivisona, Manasa , KS Divya, savitha Technologies Used In Underwater Wireless Communication, International Journal of Innovative Research in Computer and Communication Engineering Vol. 5, Special Issue 6, July 2017.
- [9] Guobao Xu , Yanjun Shi , Xueyan Sun and Weiming Shen Internet of Things in Marine Environment Monitoring: A Review , www.mdpi.com/journal/sensors

