



# STUDY ON A TECHNIQUE OF IOT AND MACHINE LEARNING BASED UNREMITTING BLOOD PRESSURE ESTIMATION

<sup>1</sup> Visnu D, <sup>2</sup> Satish bindal, <sup>3</sup> Jayanthi R, <sup>4</sup> Mohankumar G.B

<sup>1</sup> UG Scholar, <sup>2</sup> Scientist, <sup>3</sup> Associate Professor, <sup>4</sup> Head of Department.

<sup>1,3,4</sup> Electronics and Communication Engineering, Nandha College of Technology, Erode, India.

<sup>2</sup> CSIR-CEERI, Chennai, India.

**Abstract:** High blood pressure, also referred as, hypertension could be a silent killer which increases the danger of diseases like heart attack, kidney disease, metabolic syndrome and blindness. It can also cause premature death. It's necessary to monitor the blood pressure continuously, so as to stop diseases and death. The normal method of pressure measurement uses sphygmomanometer with cuff which is not an effective method to monitor the blood pressure continuously. This paper involves a different method to estimate the pressure continuously and non-invasively. We employ a technique of determining pulse transit time (PTT) parameter from obtaining the Electrocardiogram (ECG) and photoplethysmogram (PPG). The PTT is time taken by the blood pressure waves to move from one point to another point of arteries. The PTT helps to estimate the blood pressure in unremitting manner. We implement this method through low cost and reliable embedded systems design to simultaneously measure the ECG and PPG signal. Those signals are further processed to determine the PTT by applying peak detection algorithms. The PTT is further used to estimate the blood pressure. The IoT helps to monitor blood pressure and heart rate through the android/web applications.

**Index Terms -** Blood pressure, Electrocardiogram, Photoplethysmogram, Pulse transit time, Internet of Things.

## I. INTRODUCTION

Blood pressure is the force exerted by the blood when they enter the blood vessels. The blood pump is created due to contraction of the cardiac tissues. The blood pressure is recorded as systolic pressure / diastolic pressure and is measured in mm of mercury (mmHg). 120/80 mmHg is considered as normal. Below this standard value it is called as Low BP and above is called as High BP. Systolic pressure is noted when the heart contracts whereas diastolic pressure is noted when the heart relaxes.

BP is an important physiological parameter in monitoring a patient's health. It indicates various cardiovascular conditions and is also concerned in renal disease and other form of disorders. Monitoring of arterial blood pressure (BP) is highly necessary, as arterial blood pressure is a important parameter for providing critical care. BP is also a factor for cardiovascular risk.

The most commonly used device for BP monitoring is Sphygmomanometer. Although, it has high accuracy, it cannot be used for continuous readings of BP. For measuring BP continuously, an invasive method is implemented in which a catheter is inserted into the arteries. This method is ends with many side effects such as contamination, excessive bleeding, pain etc.

PTT can be used as a reliable factor of BP estimation. According to Barmwell-Hill equation, PTT is inversely proportional to BP. PTT is the time that pressure waves take to propagate between two peripheral arterial sites within a cardiac cycle. The PTT can be used for continuous and noninvasive measurement of BP.

## II. OBJECTIVES

The main objective of this project is to estimate the blood pressure continuously and non-invasively using some low cost modules. According to the World Health Organization (WHO) report, an estimated 1.13 billion people worldwide have hypertension, most (two-thirds) living in low- and middle-income countries and also the hypertension is a major cause of premature death worldwide. The blood pressure is a vital parameter which can vary suddenly and causes various effects. By monitoring the blood pressure continuously those effects are avoidable.

### III. EXISTING SYSTEM

In the existing system, a device called sphygmomanometer is used to measure the blood pressure. It uses cuff, which is fastened around the arm or wrist. Then the cuff is inflated using air pump. The pressure meter is used to monitor the cuff's pressure and by varying the cuff's pressure systolic and diastolic pressure are measured. If the BP is measured continuously using the normal method, the pressure applied to wrist or arm make the patients unable to perform hand movement and may cause irritation over long time so, it cannot be used for continuous BP measurement.

### IV. PROPOSED SYSTEM

In this system, we propose a method to estimate the blood pressure continuously and non-invasively using low cost modules. This method will avoid the need of cuff used in the blood pressure measurement. We implement a technique which will estimate the blood pressure through Pulse transit time parameter (PTT). We have created a machine learning which helps to predict the Blood pressure. The below block diagram represents the proposed system.

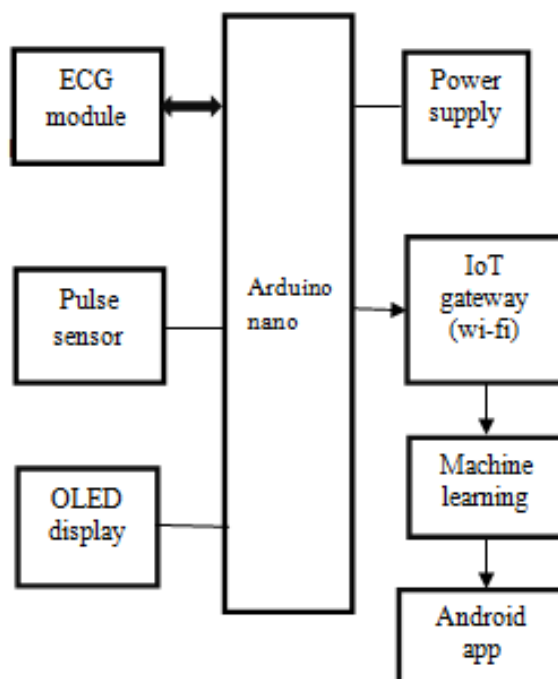

### V. METHODOLOGY

#### 1. Sensors and Data Acquisition

First, the pulse sensor (SEN-11574) is used to acquire the required information about blood motion in the form of photoplethysmogram (PPG) signal. Pulse sensors consist of light emitting diodes and optical detectors. They give graphical representation of volume changes of blood through the blood vessels. Pulse sensors can be placed on peripheral arterial sites to obtain PPG signal. In this paper, pulse sensors are placed on the tip of middle finger.



Fig. 1 the Pulse sensor is held to the finger.

Second, the ECG waveform is obtained through the ADS1292R module. The ECG Signal represents the electromechanical activity of the heart graphically. It is a vital physiological parameter, which is being used for knowing the state of cardiac activity. Here the ADS1292R module developed by the Texas Instruments (TI) used for obtaining the ECG datasets through leads. It is dedicatedly designed for portable, Low-power medical ECG, fitness and sports applications. It uses SPI protocol to communicate with microcontroller and the transfer the ECG datasets. The both acquired ECG and PPG datasets are saved in a .csv file.

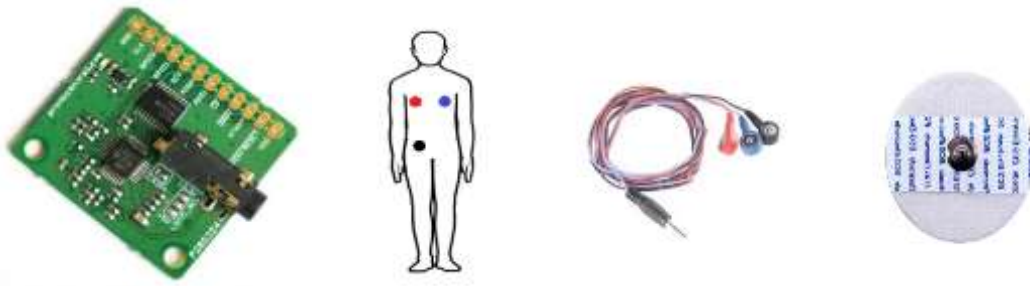

Fig. 2 The ECG leads to be placed on chest/wrist.

Third, the Arduino nano is used to acquire the ECG data from ADS1292R and PPG data from pulse sensor (SEN-11574). The Arduino nano has an inbuilt ATmega 328p microcontroller which acts as a data acquisition tool in this project.

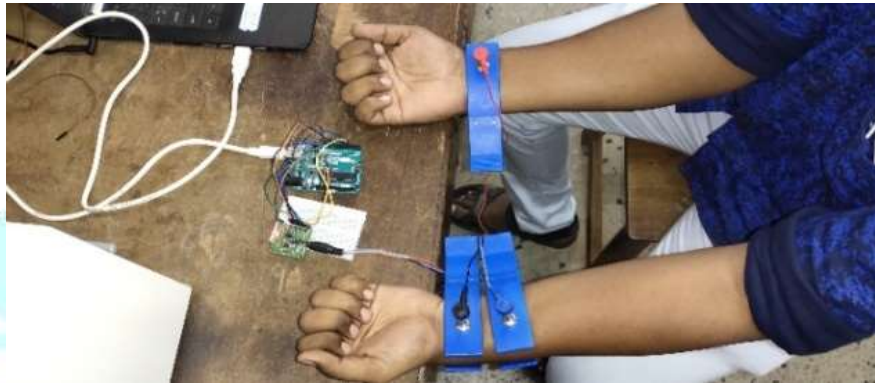

Fig. 3 Interfacing ECG module with microcontroller.

## 2. Obtaining ECG and PPG data

First, the ECG data is collected from ADS1292R module. The ECG signal has an important role in diagnosing cardio related diseases and assuring the healthy functioning of heart. The ECG is obtained by electrodes attached to the outer surface of the body. ECG signals are recorded by a specific device. The contraction and relaxation mechanisms of the heart produce an electrical potential difference on various points of the heart. The electrical signals produced will propagate to all nearby soft tissues and let the physician to measure the difference between these potentials using particular hardware. The obtained datasets are continuously plotted as an ECG signal.

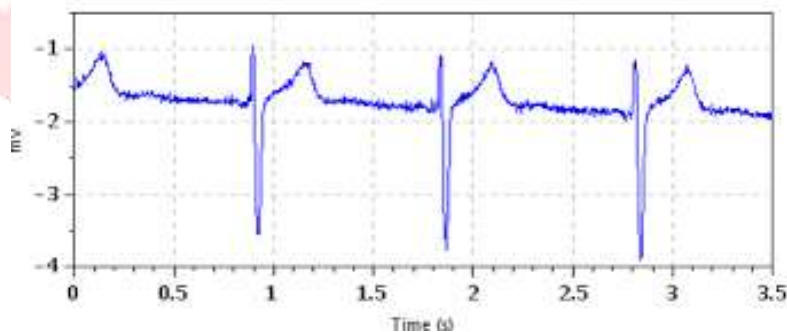

Fig. 4 ECG waveform has obtained from ADS1292R.

Second, The PPG data is collected from the pulse sensor (SEN-11574). The pulse sensor radiates the light of certain wavelength on the skin surface, the blood volume changes in the blood vessels due to the systolic and diastolic state absorbs different amount light from pulse sensor the remaining light are reflected back to the sensor and they are captured by the photo detector in the pulse sensor. The obtained signal is plotted into the PPG waveform.

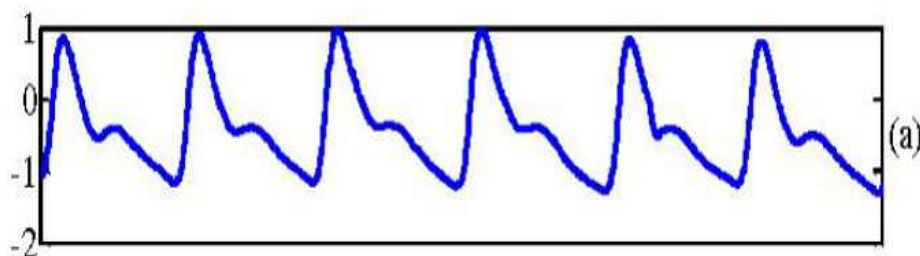

Fig. 5 PPG waveform has obtained from Pulse sensor.

Define abbreviations and acronyms the first time they are used in the text, even after they have been defined in the abstract. Abbreviations such as IEEE and SI do not have to be defined. Do not use abbreviations in the title or heads unless they are unavoidable.

### 3. Applying peak detectors to obtain the peaks of the signals

For the ECG waveform, the QRS detection Algorithm can be implemented to detect the peak of the waveform. It's necessary to detect the peak of ECG and PPG waveforms since, the PTT parameter is time delay between the R peak of ECG waveform and the peak of PPG waveform.

### 4. Calculation of pulse transit time

The PTT is a cardiovascular parameter that is typically measured by a combination of Electrocardiography (ECG) and Photoplethysmography (PPG). Thereby, the time difference between the stimulation of the heart (electrically measured by an ECG) and the arrival of the blood pulse wave at a specific measuring site (optically measured by a PPG) is calculated. The PTT can be defined more appropriately, as the time the pulse wave needs to travel a certain distance in the arterial tree.

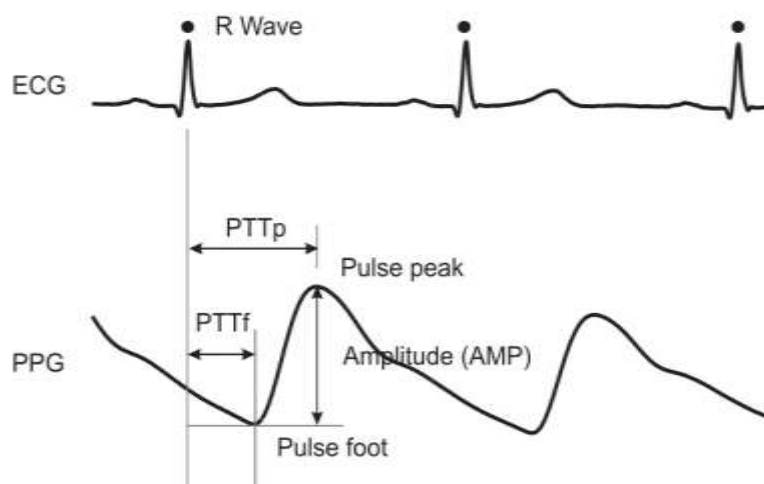

Fig. 6 PTT is determined through ECG and PPG.

### 5. Estimation of Blood Pressure

Here, Machine learning is used for the estimation of systolic arterial pressure (SAP) and diastolic arterial pressure (DAP). We have developed and trained a Machine learning model with various datasets. That model is going to estimate the blood pressure. Arterial blood pressure has an inverse relationship with PTT: when one increases the other decreases and vice versa. After calculating PTT from ECG and PPG the datasets are provided to the ML model. Through the ML model blood pressure can be estimated.

### 6. Implementation of IoT

The Internet of Things (IoT) is the method of connecting different physical objects into a network through which they can communicate between themselves and with devices in other networks without the human interaction. Here the controller can make a connection with the internet through Wi-Fi module. After connecting with internet the controller can transfer / receive the data to online platforms and mobile applications.

## VI. RESULTS

The machine learning model is developed and trained with the datasets. The Blood pressure and the pulse transit time is inversely proportional. Since there is linearity between them the “linear Regression” model is used to estimate the blood pressure. The actual BP is also measured with the volunteers using the Sphygmomanometer. The estimated BP and actual BP is plotted as the graph.

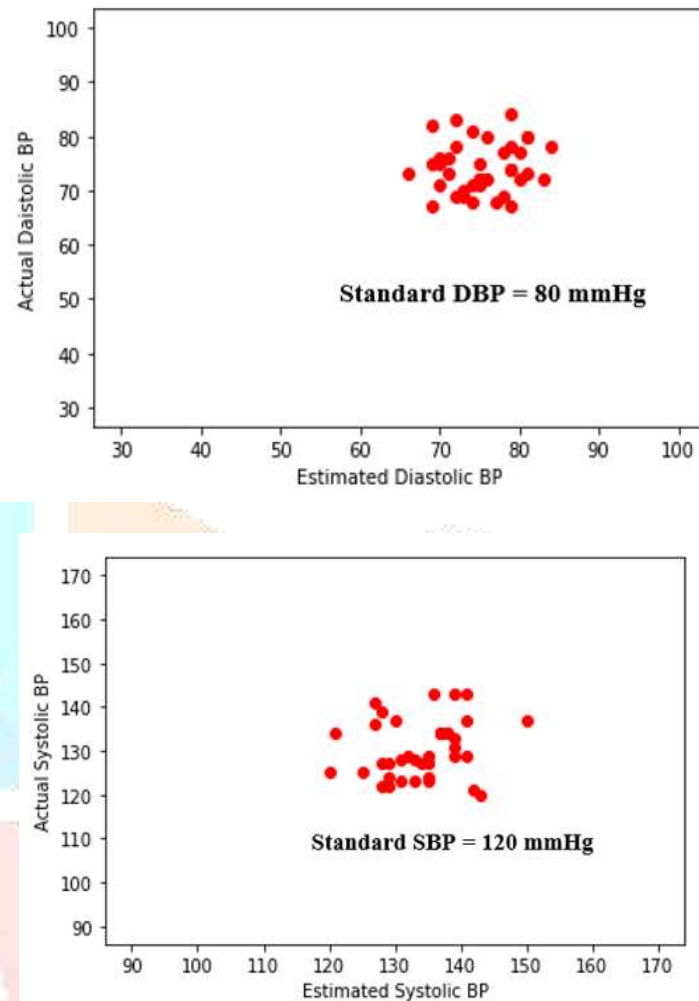

Fig. 7 Graphs plotted as Estimated BP vs Standard BP.

## VII. CONCLUSION

The PTT derived from ECG along with PPG to estimate BP can be used but it has some limitations like PEP, synchronization of both signals and problem of taking time as reference due to disparity in iso-volumetric contraction of left ventricle. The limitations can be rectified through further research and the project can be further developed into a wearable device.

**VIII. REFERENCES**

- [1] FATEMEHSADAT TABELI 1 , JON MICHAEL GRESHAM 1 , BEHNAM ASKARIAN 1 , KWANGHEE JUNG 2 , AND JO WOON CHONG 1, "Cuff-Less Blood Pressure Monitoring System Using Smartphones "Received December 3, 2019, accepted December 29, 2019, date of publication January 8, 2020, date of current version January 17, 2020.
- [2] M. Kachuee, M. M. Kiani, H. Mohammadzade, M. Shabany, Cuff-Less High-Accuracy Calibration-Free Blood Pressure Estimation Using Pulse Transit Time, IEEE International Symposium on Circuits and Systems (ISCAS'15), 2015.
- [3] L. Acef, F. Bouzergui, S. Benouar, A. Hafid, and M. Ferroukhi, "Low cost Electronic Instrumentation Solutions for Cardiovascular Parameters Measurement,"International Conference on Advanced Electrical Engineering (ICAEE 2019), Algeria 2019.
- [4] Jing Liu, Bryan P. Yan, Yuan-Ting Zhang, Fellow, IEEE, Xiao-Rong Ding, Peng Su, and Ni Zhao, "Multi-Wavelength Photoplethysmography Enabling Continuous Blood Pressure Measurement With Compact Wearable Electronics "IEEE TRANSACTIONS ON BIOMEDICAL ENGINEERING, VOL. 66, NO. 6, JUNE 2019.
- [5] MerzakFerroukhi, LyliaAcef and Mokhtar Attari,"Robust and reliable PPG and ECG integrated biosensor "978-1-7281-3156-6/19/\$31.00 ©2019 IEEE.
- [6] Po-Kai Chan, Chi-Chun Chen, and Chin-Lung Yang, "Systolic and Diastolic Blood Pressure Estimation from Pulse Transit Time Using Dual Split-Ring Resonators with Notch Structure "978-1-7281-1309-8/19/\$31.00 © 2019 IEEE.
- [7] AnaghaSavkar, PrathameshKhatate, Dr.C.Y.Patil, "Study on techniques involved in tourniqueteless blood pressure measurement using PPG "978-1-5386-2842-3/18/\$31.00 ©2018 IEEE.
- [8] N. Beckmann, R. Viga, A. Dogangün, and A. Grabmaier, "Measurement and Analysis of Local Pulse Transit Time for Emotion Recognition "IEEE SENSORS JOURNAL, VOL. 19, NO. 17, SEPTEMBER 1, 2019.
- [9] MuskanSingla, Prasad Sistla and Syed Azeemuddin, "Cuff-less Blood Pressure Measurement Using Supplementary ECG and PPG Features Extracted Through Wavelet Transformation "978-1-5386-1311-5/19/\$31.00 ©2019 IEEE.
- [10] Bassem Ibrahim, Student Member, IEEE, and RoozbehJafari, Senior Member, IEEE, "Cuffless Blood Pressure Monitoring from an Array of Wrist Bio-Impedance Sensors Using Subject-Specific Regression Models: Proof of Concept" IEEE TRANSACTIONS ON BIOMEDICAL CIRCUITS AND SYSTEMS, VOL. 13, NO. 6, DECEMBER 2019.