



DRUNKEN DRIVER ACCIDENT PREVENTING PARKING SYSTEM WITH ASSISTED HELP

Faris Usman , Lakshmi.M, Rehna K.R, Abdul Salam

B.Tech Students

Ms.Vidya Hari

Asst.Professor

Department of Computer Science & Engineering

KMEA Engineering College, Edathala, Aluva

Kerala-India

ABSTRACT

This project is creating a smart way for preventing drunken driver from accessing their vehicle and hence by preventing a disaster from its starting point. This system is indeed a smart vehicle parking system with every feature including smart parking based on priority, time base etc and all the security feature with fool proof accessing using RF id card assigned to use the parking system. All data's are logged in to a central memory system and also using cloud computing to process these data. The difference from other parking system is that it has some advanced features like voice interactive system to operate and screening the vehicle owners for alcohol test before they access their vehicle and verifies them if they are safe for driving their vehicle. Else the system will offer them choices like hiring a driver for their vehicle or rent a cab to reach their destination, or providing them to a customer care support to assist their further needs. If the user is too tired or drunken the system will detect it using its pre-programmed conditions and will call for floor security for further help and medical assistance. That is not all, the system itself have a large database and computing power to find out consecutive law breaking alcohol addicted drivers and it will send their data to de-addiction centres and make them red flagged unless they complete their treatment and come as a new law abiding citizen

1.INTRODUCTION

Day by day the increasing number of road accident is mainly due to drunken driving or rough driving rather than any technical fault and the most damage and destructions caused accident should always be the drunken driving. Many innocent people who didn't do anything wrong will have to suffer its consequence because of some other people's drunken habit, and most cases they will lose their life.

The increasing number of vehicle in the street and the lack of parking area or space and there is a bad habit in the people that users are parking their vehicle in the pedestrian area of the road or some time even in the road itself

which will force the pedestrians to walk through the road and cause accident or traffic blocks. So this project is creating a new way of parking system which will utilise almost all the space in the parking area and also even create big indoor parking system with mechanised parking system and it can store large group of vehicle details without any error or trouble and can retrieve the vehicle in any time without error and even set specific time interval for parking.

2. LITERATURE SURVEY

Rongxing Lu, Xiaodong Lin, Haojin Zhu and Xuemin [1] proposed a new smart parking scheme for large parking lots through vehicular communication. This scheme can produce the drive with real time parking navigation services, intelligent anti-theft protection and friendly parking information dissemination. Performance analysis via extensive stimulations demonstrate its efficiency and practicality.

From IOT based smart parking system by SaidurRahman[2] proposed a parking system that delivers information to people finding a parking space online. It overcome unnecessary time consumption for finding the problem of parking space in parking areas. Hence the website is provided by the project is based on system where user can view various parking areas and choose the space from available slots.

From the first case study, the device will emit radio frequency waves and triangulation technique, which is used for this smart parking system. In this project 3 towers were implemented and signals are generated from the towers. Triangulation is done by calculating the time distance. The drawback is that it can be easily by using a signal camera. The radio frequency generates noise when the car's ignition starts and also its implementation cost is high.

When coming to the second case study, it is the best way to find out the parking and providing the precise vacant position of parking slot.

Once coming to this proposed project, it provides not only an alcohol test so that drunken driving can be avoided but also a smart parking system. Like the first case study this project uses the same sensor and ultrasonic sensor like PIR sensor provide the vehicle with proper parking lane and also have a vehicle parking assistance help.

3.PROPOSED DESIGN

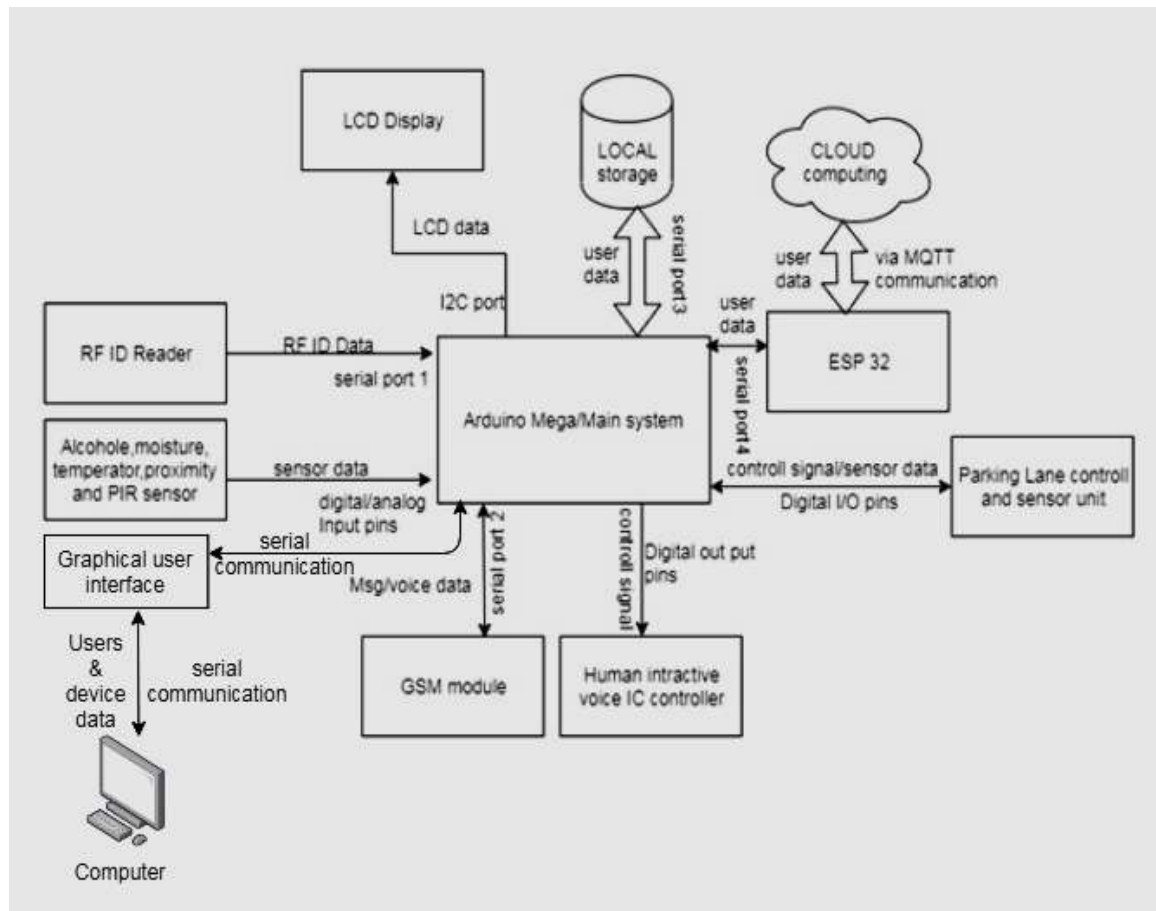

Here Arduino Mega is acting as the main system and it can work independently without the help of any other processing unit or internet. The Arduino Mega is connected a bunch of sensors which will help it to understand and help the user and directly interact with the user using its voice interactive communication method.

The computer and graphical user interface is only for the initial user registration to the system, other than that the system relies on the local memory unit which contains all the user information and log details which is needed for the proper working of the system.

Here ESP32 is used to establish a MQTT communication and synchronizing data in the memory module with the cloud computing platform to process certain data like, drinking habit persons, their treating information, contact numbers etc. which will then be send to doctors and de-addiction centers and community to cure the persons drinking addiction.

The sensors used in this projects are MQ3 sensor which is used for alcohol level in breath, DHT11 which is a temperature and humidity sensor which is used to detect the temperature and moisture level of the breath while the alcohol test and verifies the person is actually blowing air to the sensor rather than fooling it by not blowing air. The next thing to fool proof the test is by using proximity sensor which will constantly measure the distance between users face and the alcohol sensor. Another sensor used in this project is PIR sensors which is motion detection sensor which can identify if a user is approaching the device or not and start its work

Here the RF id reader is used to identify the user using their RF id card. Here MFRC522 card and reader are using, users are registered in the system base on the unique RF id number. Here a LCD display is used primarily for displaying the number of parking lane available, but after the user approached the system in short interval it will started to display the user instructions same as that plays in the voice interactive, so the deaf people can also interact with the system without any trouble.

The GSM module is used to establish the telephone connection with call center so that when the user press for call center help button he can talk to the representative and provide necessary help. Also the GSM module is used to send messages to the user reminding their parking time expiration (for temporary users), for alerting floor security etc.

The human interactive voice IC module is consist of a memory module which contains all the user instructions, voice commands which is necessary for the complete running of the platform. The module will play those voice commands and instruction when main system tells it to like it will play the welcome voice note when a user approach to the system. Here the system is identifying the users approach by the sensors output(in this case PIR sensor) and determine it and send the welcome track play commands for every situation it have specific voice track.

The parking lane control and sensors unit is combination of lane assisted parking system where each lane have a lane lock system and vehicle parking area. When a user approach the individual designated lane area the lane will open and allow the user to park inside the lane, while parking the vehicle position is measured using proximity sensors and provide feedback to the system and the system will tell if any correction is needed for the vehicles parking positions. Once it is corrected and user exit from the vehicle and the lane, the lane will automatically close the lane lock

4. MATERIALS AND METHODS

Below figure (Fig1) will shows the impact of drunken driving in the past recent years and how much human innocent life took on these years.

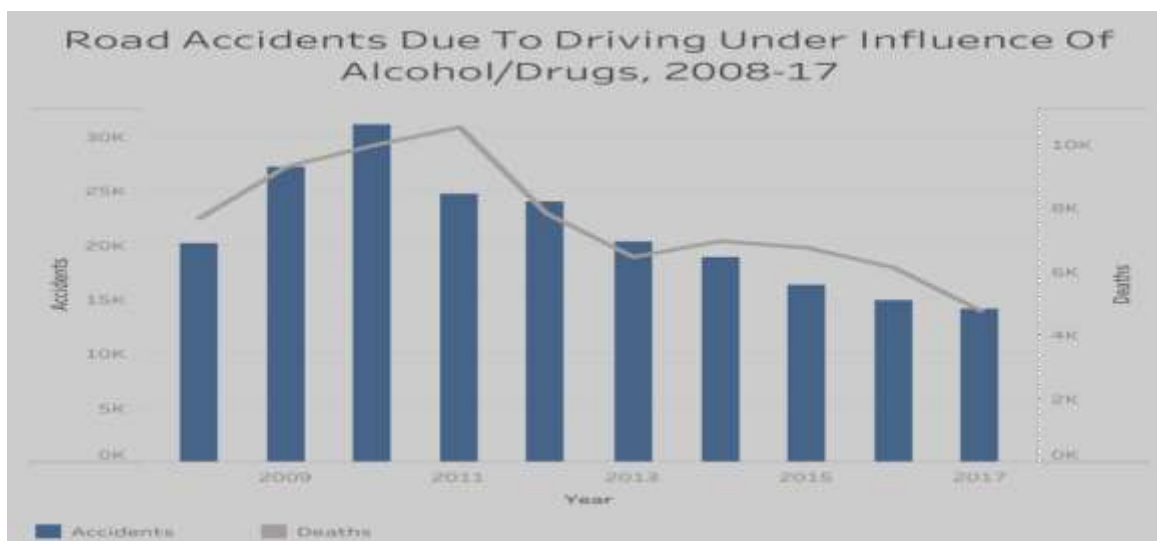

Fig 1: http://www.kerennis.nic.in/database/infrastructure_812.aspx

Now in the case of vehicle population in Fig 2 and 3 it can see that an enormous growth on the number of vehicle owners and small growing country like India our road and space infrastructure is very small compared to these rapid increase in vehicle population.

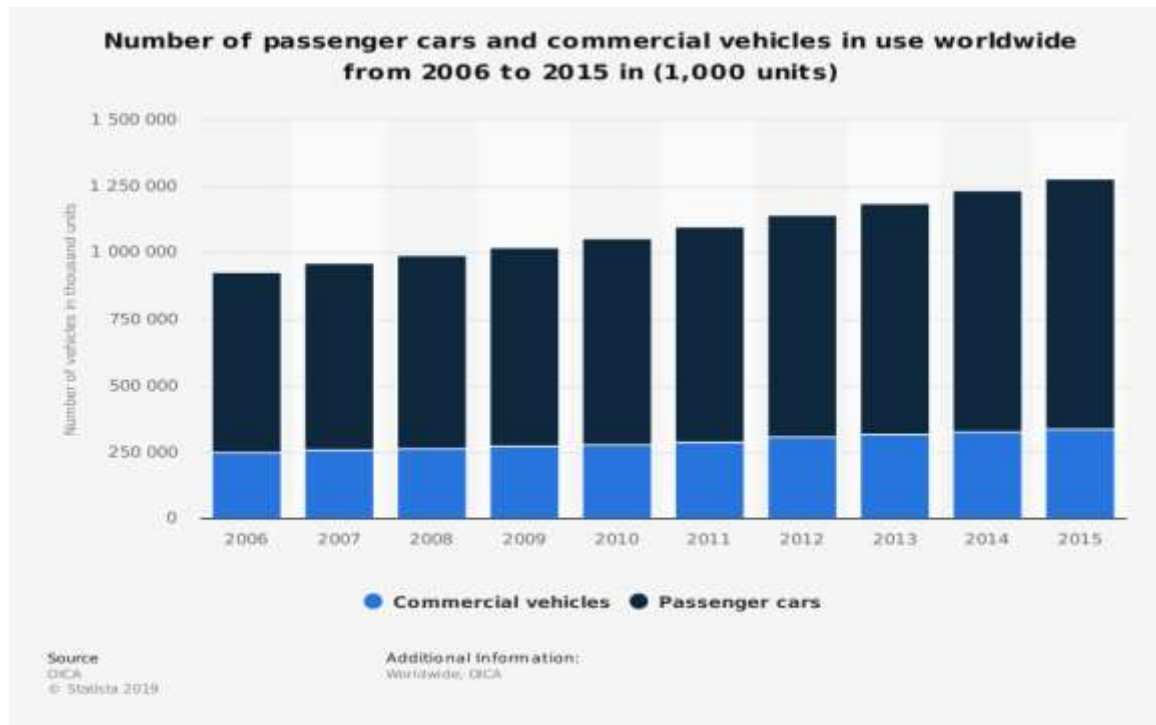

Fig 2: Number of vehicle registered in Kerala

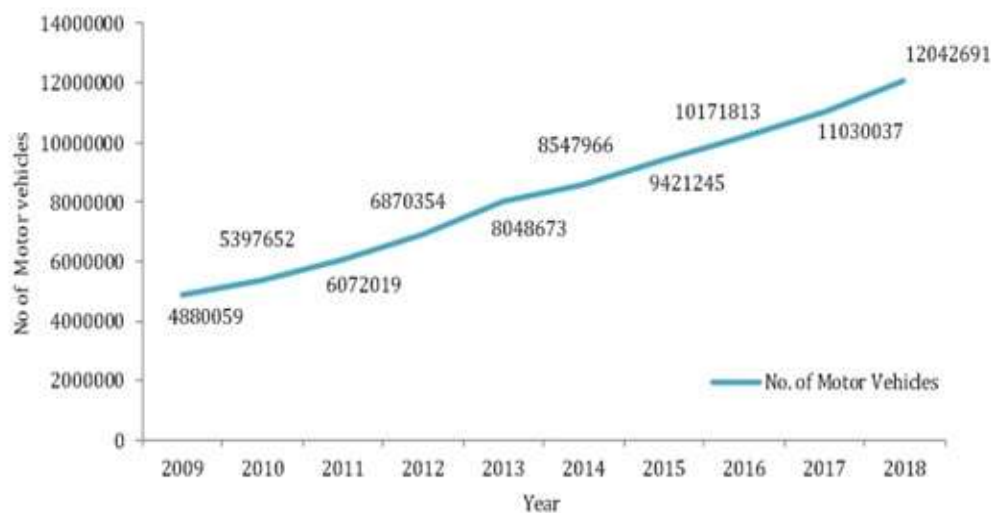

Fig 3: http://spb.kerala.gov.in/ER2017/web_e/ch51.php

Kerala has 120.42 lakh registered motor vehicles as on March, 2018. For the last two decades it has experienced a compounded annual growth rate of above 10 percentage. The number of vehicles per 1,000 populations for Kerala as on March 2018 is 361. According to world development indicators (2015), number of vehicles per 1,000 populations in India is 18, China 47 and United States 507. The growth of vehicle population in Kerala is eight percentage over the previous year. The growth of Motor Vehicles during last ten years is shown above in fig 3.

In order to solve our two problems, drunken driving and lack of space for parking. Unlike our government's policy by increasing fine to counter the drunken driving, employing a new technique by giving them assisted help and also warning them not to repeat and if it repeat more times, device will sending their data to de-addiction centres and community to get cured.

In this vehicle parking system there are 3 types of users, one is VIP user, where this user have special lane reserved for their use and also can use that lane whenever wanted and without any time limit with their smart card.

The second type of user is normal pre-registered user where this users don't have any reserved lanes, the lanes are allocated based on the availability but user also don't have any time limit.

The third type of user is guest user and the security will give them a smart card which will be temporally assigned to their vehicle, this type of user have time limit for their parking and once time limit exceeds the user will be notified twice with messages and user can renew the timing by calling the customer care with valid reason or else the vehicle will be impounded.

Once the vehicle owner approach the main barricade with their vehicle the device will ask them to scan their card and once the card is verified the device will open the main barricade and will unlock a lane based on the availability and user type. Once the user parked the car inside the lane and stepped outside the vehicle and lane user can lock the lane by pressing red button outside the lane or it will lock the lane automatically. Once the preset time is over (inside every lane there is a panic button to call the security if trouble occurs) and they can use the smart card to walk outside.

Once the user approach for the parking lot to get their vehicle back the device will automatically detect the person and it will ask them to enter the security card (key pad number code or RF id card) to verify their identity, ones it verify the owner it will ask the user to step out to the alcohol sensing area to get ready for test.

Once user is close to the sensor it will blink a status ready led and ask the user to blow the air to the sensor (if the user is not close to the sensor the status ready led will not blink and device will tell the user to move closer until he reach the required distance), once the user give the breath to the sensor it will check two things, one is obviously the alcohol level to know whether the user is drunk or not and the temperature and moisture level of the breath to check if he is not fooling the machine by blowing fake air to the machine.

Once the test is done and everything is correct the main barricade will open itself and welcome the user and unlock his car parking lane where the user parked the car and allowed to drive out.

If the user is failed in the test and the alcohol level is high the door will explain to the user that, blood alcohol level is high and it's not safe to drive his vehicle alone and ask user to press one of the three button, where the user press first button to rent a cab to pick up, press the second button to rent a driver to drive the user safely and press third button to talk to the customer executive.

If the user press the first button the system will send a message with users name, phone number and location to the cab booking service, it will follow up the procedure and will help to reach the destination.

If the user presses the second button the system will send a message with users name, phone number and location to the driver booking service along with a newly generated driver id code, which can be used to identify the driver unlock the door when he passes the alcohol test.

If the user presses the third button the system will initiate a call to the customer care number assigned to the user and he can talk to them for further assistance and the customer executive have an additional power that in case of emergency he can let the user to open the door by sending the master code to the door to over ride the security.

If the user was unable to press any of that three buttons the door will call the floor security to help the user.

In this project cloud computing is using to store and process user data for detecting and finding repeated drunken drivers, registering guest users etc.

And using MQTT communication protocol to establish connection with device and the cloud. Here ESP 32 used to make this device an IOT device to establish connections and networking. But this device will even work without internet by using its backup memory module.

5. CONCLUSION

Let it be a safer place to drive and walk through the pavement without afraid of the drunken drivers, and let it be the safest place on earth with no alcohol addicted person and family who suffer because of their continuous drinking habit.

With the increase in population and increase in number of vehicle this project can manage more number of vehicles than traditional parking system.

REFERENCES

1. SPARK: A New VANET-based Smart Parking Scheme for Large Parking Lots Lu†, Xiaodong Lin‡, Haojin Zhu†, and University of Waterloo, Waterloo, of Ontario Institute of Technology, Oshawa, Ontario, Canada L1H Ontario, Canada N2L 3G1 ‡Faculty of Business and Information Technology, University 7K4 Email: {rxlu, h9zhu, xshen}@bbcr.uwaterloo.ca; Xiaodong.Lin@uoit.ca Xuemin (Sherman) Shen† †epartment of Electrical and Computer Engineering,
2. IOT Based Smart Parking System- Saidur Rahman Lecturer, Department Of Computer Science and Engineering, Daffodil Institute of IT, Dhaka Bangladesh, Poly Bhoumik Lecturer , Department of Computer Science and Engineering, Daffodil Institute of IT, Dhaka Bangladesh
3. based Smart Parking System Abhirup Khanna University of Petroleum and Energy Studies (UPES) Dehradun, Uttarakhand abhirupkhanna@yahoo.com Rishi Anand University of Petroleum and Energy Studies (UPES) Dehradun, Uttarakhand rishi.anand0@gmail.com
4. Zheng, Y., Rajasegarar, S., & Leckie, C. (2015, April). Parking availability prediction for sensor-enabled car parks in smart cities. In Intelligent Sensors, Sensor Networks and Information Processing (ISSNIP), 2015 IEEE Tenth International Conference on (pp. 1-6). IEEE
5. Botta, A., de Donato, W., Persico, V., & Pescapé, A. (2014, August). On the Integration of Cloud Computing and Internet of Things. In Future Internet of Things and Cloud (FiCloud), 2014 International Conference on (pp. 23-30). IEEE.