



## EXPERIMENTAL STUDY OF CONCRETE FILLED STEEL COLUMNS

**Shanmuga Priya K**

PG Student,  
Dhirajlal Gandhi College  
of Technology,  
Salem,  
Tamil Nadu

**Karthick R**

Assistant Professor,  
Dhirajlal Gandhi College  
of Technology,  
Salem,  
Tamil Nadu

**Chandrikka V**

Assistant Professor,  
Dhirajlal Gandhi College  
of Technology,  
Salem,  
Tamil Nadu

### ABSTRACT

Steel-concrete composite columns are used widely in modern buildings. Extensive research on steel concrete composite columns in which structural steel sections are encased in concrete have been carried out. In-filled composite columns, however have received limited attention compared to encased columns.

This paper includes the review done on steel columns in which concrete are in-filled. Wire mesh is welded on the inside surface of steel column to increase the bond between steel and concrete. Three composite columns (short columns) are compared with three RC columns of same size. Ultimate strength, ductility, energy absorption capacity and stiffness of columns are noted. It is observed that composite columns show better structural behavior than RC columns.

**Keywords:** Steel-concrete composite columns, In-filled composite columns, bond, Ultimate strength, ductility, energy absorption capacity and stiffness.

### 1 INTRODUCTION

#### 1.1 GENERAL

With the increasing use of composite construction worldwide, there is a growing interest in utilizing Concrete - Filled Tubes (CFTs) as a primary column member. The interest develops from the fact that properties of steel and concrete in the CFTs are fully utilized, so that the strength, stiffness and ductility of the structures constructed from CFTs can be enhanced simultaneously. Since the function of longitudinal reinforcement and transverse confinement can be acquired due to presence of the steel tubes, the traditional longitudinal and transverse reinforcement may be eliminated. This type of column also maintains sufficient ductility when high strength concrete is used.

CFT columns can replace conventional structural columns like reinforced concrete, structural steel with reinforced concrete and structural steel alone with enhanced performance and at the same time reducing costs to a minimum. It is especially useful in high-rise buildings where high strength is required and flexibility of open space is desired for a maximum range of applications.

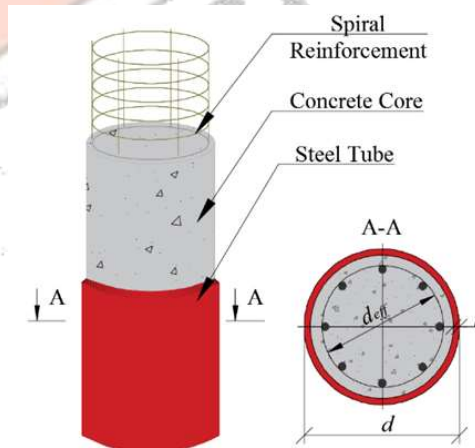


Fig. 1. Concrete-encased steel sections

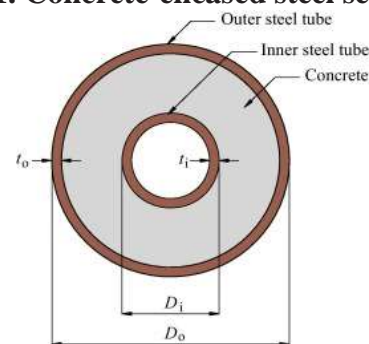


Fig.2 Cross section of CFT

## 2 LITERATURE REVIEW

Dabaon et al. (2009) had done experiments on five hollow columns and ten concrete filled columns. Tests had performed to investigate the effect of concrete core. Comparison had made between stiffened hollow sections and concrete filled specimens. Results indicated that to increase the capacity of slender stainless steel stiffened tubular stub columns, in-filled concrete must be used. It also indicated that increasing the nominal compressive strength of the in-filled concrete leads to smaller column size.

Thayala et al. (2009) had done an experimental investigation to study the behavior under static and variable repeated push out loads. A total of 12 CFST and 7 HST columns were constructed. Results showed that the ultimate strength of composite columns had reduced after undergoing a number of cycles of repeated loads.

Lin-Hai Han et al. (2011) had done experiment by testing eighteen specimens. Main parameters studied were steel ratio, concrete type, and bond or unbonded between steel tube and its core. Compared with the hollow steel tube, the tensile strength of CFST specimen had enhanced due to infilling concrete. Bond or unbonded between the steel tube and its core concrete has moderate effects on the tensile strength of CFST.

Prakash et al. (2012) presented a paper on modified push-out tests. This paper presents, modified push-out tests conducted for the determination of shear strength and stiffness of high strength steel (HSS) studs. The HSS studs having ultimate strength of 900 MPa and yield strength of 680 MPa were used in the modified push-out specimens. Novelty of this study may be considered in highlighting the importance of confined concrete strength while designing push out specimens. It could be concluded from present experimental study that confinement of concrete near HSS stud significantly enhanced the compressive strength as well as splitting resistance of concrete. Therefore, it must be considered while designing concrete specimens for push out specimens.

Serkan Tok goz et al. (2012) done an experimental study to investigate the influence of steel fibers on the structural behavior of biaxial loaded L-shaped high strength reinforced concrete and concrete encased composite columns. Sixteen column specimens had been prepared and tested in this study. The test variables included concrete compressive strength, load eccentricity, steel yield stress, slenderness effect and steel fiber content.

Radhika et al. (2012) presented an experimental study on circular concrete filled steel tubular columns. Parameters for this study included the length to diameter ratio of the steel

tube, grade of concrete and the effect of addition of metakaoline in concrete. The effect was most pronounced for the stub column with bond strength between the concrete core and the steel tube, when the load applied only to the concrete section. The stiffness was also influenced by the changed bond strength for this loading situation. Increased bond strength resulted in a greater contribution from the steel tube, i.e. stiffness of the column increased. Finally, even though the efficiency of the steel tube in confining the concrete core was greater when the load is applied only to the concrete section, it seems not reliable to trust just the natural bond strength to get full composite.

Krishna Murthy (2012) studied that self-compacting concrete (SCC) possesses enhanced qualities and improves productivity and working conditions due to elimination of compaction. SCC was suitable for placing in structures with congested reinforcement without vibration and it helps in achieving higher quality of surface finishes. The relative proportions of key components were considered by volume rather than by mass. A simple tool has been designed for self compacting concrete (SCC) mix design with 29% of coarse aggregate, replacement of cement with Metakaolin and class F fly ash, combinations of both and controlled SCC mix with 0.36 water/cementitious ratio (by weight) and 388 litre/m<sup>3</sup> of cement paste volume.

Zhong Tao et al. (2011) carried out push-out tests on 64 concrete-filled steel tubular columns, which had been exposed to ISO 834 standard fire for 90 minutes or 180 minutes, respectively. At the same time, 12 unheated specimens were also prepared and tested for comparison. The variables investigated in the bond tests were selected as fire exposure time, cross-section type, and cross-sectional dimension, interface length to diameter ratio, concrete type, fly ash type and concrete curing condition. The effects of the above different parameters on bond behaviour were discussed. The test results indicate that fire exposure had a significant effect on the bond between a steel tube and its concrete core.

Ehab Elloby et al. (2011) presented a nonlinear 3-D finite element model for eccentrically loaded concrete encased steel composite columns. The columns were pin-ended subjected to an eccentric load acting along the major axis, with eccentricity varied from 0.125 to 0.375 of the overall depth ( $D$ ) of the column sections. The finite element model had been validated against existing test results. The concrete strengths varied from normal to high strength (30–110 MPa). The steel section yield stresses also varied from normal to high strength (275–690 MPa). Furthermore, the variables that influence the eccentrically loaded composite column

behaviour and strength comprising different eccentricities, different column dimensions, different structural steel sizes, different concrete strengths, and different structural steel yield stresses were investigated in a parametric study.

Type of column	Length (mm)	Breadth (mm)	Width (mm)
RC Column	1020	100	100

**Table 2 Details of steel concrete composite column**

Type of column	Length (mm)	Breadth (mm)	Width (mm)	Thickness of steel	L/b	b/t
Steel column	1020	100	100	1.25	10.2	80

**Table 3 Details of RC column**

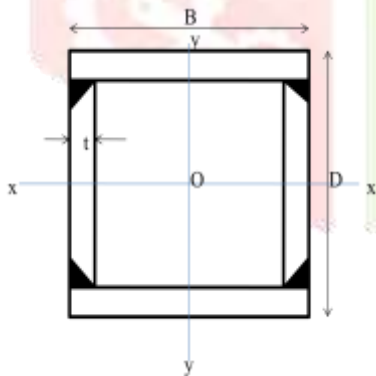
**Table 1 Concrete Mix Proportion (M60)**

Cement	Fine Aggregate	Coarse Aggregate
1	1.56	2.2

**3 PREPARATION OF SPECIMEN**

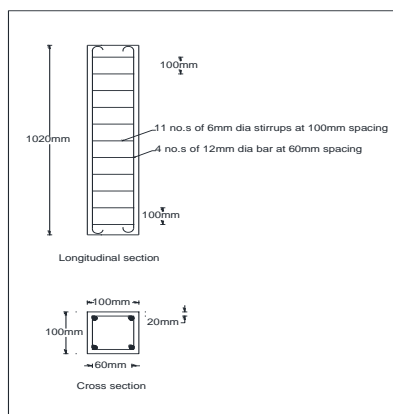
Six specimens were tested under concentric axial load. Three of them were concrete infilled steel columns and the other three were conventional RC columns of M30 grade. The aim of the experimental study was to determine not only the maximum load capacity of the specimens, but also to investigate the behavioral pattern up to and beyond ultimate load.

Fig.3 shows the cross section of the welded square tube, where B and D are the width and the depth of the square steel tube respectively and t is steel wall thickness. The tubes were all manufactured from mild sheet, with four plates were cut from the sheet, tack welded into a square shape and then welded at the corners.

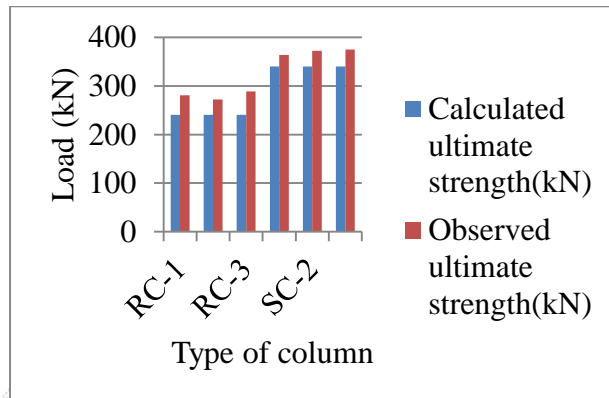


**Fig 3**

**Cross section of steel column**



**Fig.4 Reinforcement details of RC column**



**Fig.4 Ultimate strength test results**

**3 CONCLUSIONS**

From the detailed study of this paper the following conclusion was made.

- To optimise the mix proportion of conventional concrete by casting cubes and cylinder.
- To increase the capacity of empty steel columns, in-filled concrete must be used.
- Compared the hollow steel tube with the CFST specimen .
- Columns tested under axial loading showed that the increase of the concrete strength has a positive effect on the load carrying capacity of concrete-filled steel tubes.
- Since there is no use of formwork and reinforcement, steel concrete composite columns are cost effective.
- The only disadvantage in the case of concrete infilled steel column is that, fire protection is not ensured.
- Quality control in the of pouring of concrete is very important in achieving good strengths for concrete filled steel columns. Better compaction will result in higher member capacities.
- In short columns with the load applied axially to the section, the column showed better results than predicted due to the confinement of the steel tube.

**REFERENCES**

1. Amar Prakash., N.Anandavalli., C.K.Madheswaran and N.Lakshmanan (2012), “Modified push-out tests for determining shear strength and stiffness of HSS stud connector- experimental study”,International journal of composite materials, Vol. No.2, pp 22-31.
2. Ehab Elloby., Ben Young and Dennis Lam (2011) “Eccentrically loaded concrete encased steel concrete composite columns”,Journal of structural engineering, Vol. No.49, pp 53-65.
3. K.S. Radhika and K.Baskar (2012) “Bond stress characteristics on circular concrete filled steel tubular columns using mineral admixture metakaoline”,International journal of civil and structural engineering, Vol. No.3.
4. Lin-Hai Han., Shan-Hu He and Fei-Yu Liao (2011) “Performance and calculations of concrete filled steel tubes (CFST) under axial tension”, Thin walled structures, Vol. No.67, pp 1699-1709.
5. Zhong Tao., Lin-Hai Han., Brian Uy and Xian Chen (2011) “Post-fire bond between the steel tube and concrete in concrete in-filled steel tubular columns”, Journal of structural steel research, Vol. No. 67, pp 484-496.

