



## Design and Implementation of Arduino based Military Spying and Bomb Detecting Robot

Malini.P<sup>[1]</sup>, Mahalakshmi.A<sup>[2]</sup>, Prabhavathi.K.B<sup>[3]</sup>, Rinthiya Praba.G<sup>[4]</sup>, Srinidhi.P<sup>[5]</sup>

Assistant Professor<sup>[1]</sup>, Dept. of Electronics and Communications Engineering, Vivekanandha College of Technology for Women, Namakkal, Tamil Nadu, India.

Student<sup>[2,3,4,5]</sup>, Dept. of Electronics and Communications Engineering, Vivekanandha College of Technology for Women, Namakkal, Tamil Nadu, India.

**Abstract** -. Right now will blend two applications that is spying and bomb recognition. The Mini Spy Robot is little robot with a camera joined to it. The engines will be controlled by the transfers which will be then controlled through Remote by means of Bluetooth module. The work is intended to build up a War field robot which is equipped for recognizing bombs land mines in its way and which is remotely controlled through Bluetooth module. It is utilized to screen the Warfield. The robot can be moved in all the headings utilizing the remote remotely. The robot framework is additionally utilized for bomb identification .The controlling gadget of the entire framework is an Arduino. Because of that circuit intricacy is diminished and execution speed is expanded. At whatever point, land mines or bombs are identified, it alarms through GSM module. The Arduino utilized in the task are customized utilizing Embedded C language. Just by utilizing a Bluetooth module empowered, the client can control the

ARDUINO MILITARY SPYING AND BOMB DETECTING ROBOT from anyplace territory.

**Key Words:** Metal Detector, GSM/GPS, Camera, Spy Robot.

### I.INTRODUCTION

A **wireless sensor network** (WSN) is a PC arrange comprising of spatially appropriated self-governing gadgets utilizing sensors to agreeably screen physical or ecological conditions, for example, temperature, sound, vibration, weight, movement or contaminations, at various areas. The improvement of remote sensor systems was initially inspired by military applications, for example, war zone reconnaissance. Nonetheless, remote sensor systems are presently utilized in numerous regular citizen application zones, including condition and living space checking, social insurance applications, home mechanization, and traffic control.

Notwithstanding at least one sensors, every hub in a sensor arrange is regularly outfitted with a radio handset or different remote specialized gadget, a little

microcontroller, and a vitality source, generally a battery. The size a solitary sensor hub can fluctuate from shoebox-sized hubs down to gadgets the size of grain of residue. The expense of sensor hubs is comparably factor, running from many dollars to a couple of pennies, contingent upon the size of the sensor arrange and the unpredictability expected of individual sensor hubs. Size and cost requirements on sensor hubs bring about comparing imperatives on assets, for example, vitality, memory, computational speed and data transmission. In software engineering, remote sensor systems are a functioning examination zone with various workshops and meetings masterminded every year.

The applications for WSNs are numerous and differed. They are utilized in business and mechanical applications to screen information that would be troublesome or costly to screen utilizing wired sensors. They could be conveyed in wild regions, where they would stay for a long time (checking some natural variable) without the need to revive/supplant their capacity supplies. They could frame an edge about a property and screen the movement of interlopers (passing data starting with one hub then onto the next). There are a numerous utilizations for WSNs.

Run of the mill utilizations of WSNs incorporate checking, following, and controlling. A portion of the particular applications are territory checking, object following, atomic reactor controlling, fire recognition, traffic observing, and so on. In an ordinary application, a WSN is dispersed in a locale where it is intended to gather information through its sensor hubs.

## II. LITERATURE SURVEY

### 2.1 "Military Surveillance Robot Implementation Using Robot Operating System" IEEE Transactions

Robots are becoming more and more prevalent in many real world scenarios. Housekeeping, medical aid, human assistance are a few common implementations of robots. Military and Security are also major areas where robotics is being researched and implemented. Robots with the purpose of surveillance in war zones and terrorist scenarios need specific functionalities to perform their tasks with precision and efficiency. In this paper, we present a model of Military Surveillance Robot developed using Robot Operating System. The map generation based on Kinect sensor is presented and some test case scenarios are discussed with results.

### 2.2 G. Zhang, J. Furusho, and M. Sakaguchi, "Vibration suppression control of robot arms using a homogeneous-type electrorheological fluid," IEEE/ASME Trans. Mechatronics, vol. 5, no. 3, pp. 302–309

This paper presents a model for gesture controlled user interface (GCUI), and identifies trends in technology, application and usability. We present an integrated approach is real time detections, gesture based data which control vehicle movement and manipulation on gesture of the user using hand movements. A three axis accelerometer is adaption. As the person moves their hand, the accelerometer also moves accordingly. The gesture is capture by accelerometer and processed by gesture. Today human machine interactions is moving away from mouse and pen and is becoming pervasive and much mouse compatible with the physical world . With each passing day the gap between machines and human is being reduced with the introduction of new technology is easy the standard of living. Its having

future scope of advanced robotic arms that are designed like the human hand itself can easily controlled using hand gesture only. It also has proposed utility in field of construction, medical science, hazardous waste disposal etc.

### III. EXISTING SYSTEM

In existing framework all the sensors information will be put away send to the specialist utilizing Zigbee. A Wireless Sensor Network (WSN) for checking patient's physiological conditions consistently utilizing Zigbee. Here the physiological states of the patient's are checked by sensors and the yield of these sensors is transmitted by means of Zigbee and the equivalent must be sent to the remote screen for procuring the watched patient's physiological sign Infusion siphon is a clinical gadget. It is social insurance offices utilized worldwide in medical clinics, and at home. It can convey liquids both in medications and supplements, for example, torment relievers chemotherapy medications, hormones or insulin, and anti-infection agents into a patient's body in any sums. There are numerous kinds of siphons including insulin siphons, syringe, enormous volume, elastomeric, quiet controlled absence of pain (PCA), and enteral siphon. Enteral siphon is a siphon that is utilized to convey meds and fluid supplements to a patient's stomach related tract. Understanding controlled absence of pain (PCA) siphon is a siphon that is utilized to convey torment prescription. Insulin siphon is a siphon that is utilized to convey insulin to patients with diabetes which is much of the time utilized in home. These gadgets are significant for medical caretakers since they can show status of fluid that they provide for patients. Along these lines, the gadgets are well known in emergency clinics for checking status of medication

### 3.1 Disadvantages

- ✓ Improper measurement
  - ✓ Waste of time
  - ✓ Zigbee covers short distance
- So communication level is poor.

### IV. PROPOSED SYSTEM

In this proposed system, a thought of following the officer just as to give the wellbeing status of the warrior during the war, which empowers the military faculty to design the war procedures. The Mini Spy Robot is little robot with a camera appended to it. The engines will be controlled by the transfers which will be then controlled through Remote by means of RF module. The work is intended to build up a War field robot which is equipped for recognizing bombs land mines in its way and which is remotely controlled through RF module. It is utilized to screen the Warfield. The robot can be moved in all the headings utilizing the remote remotely. The robot framework is additionally utilized for bomb location .The controlling gadget of the entire framework is an Arduino. Because of that circuit multifaceted nature is decreased and execution speed is expanded. At whatever point, land mines or bombs are distinguished, it alarms through GSM module. The camera recognizes the specific area of the robot. Right now venture assumes a urgent job in Military just as in our police office. Right now, have presents another application utilizing two strategies for example spying and bomb discovery executed by utilizing Arduino unit. In future, we can likewise execute bomb dispersion strategy right now. It very well may be utilized in radar discovery frameworks to distinguish questions by executing other equipment

#### 4.1 Block Diagram

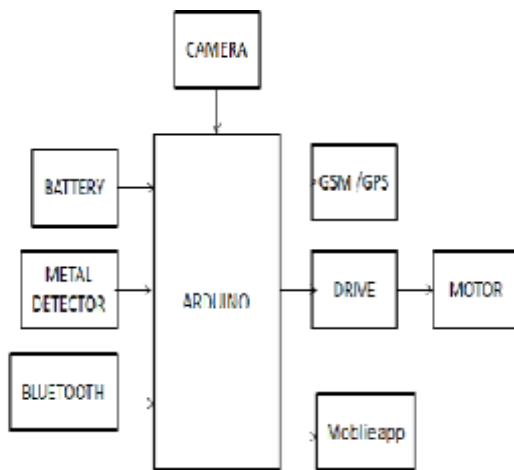

## V. SYSTEM REQUIREMENTS

### HARDWARE DESCRIPTION

#### 5.1 Power Supply

The AC supply is applied to 12V advance down transformer. The transformer yield is the 12V AC which is corrected utilizing a diode connect. The yield of Diode Bridge of 12V DC is separated by capacitors.

#### 5.2 LCD Display

LCD can show numbers, characters and designs. The showcase is interfaced to I/O port of microcontroller (P0.0-P0.7). The presentation is in multiplexed mode for example just each show stays on in turn. Inside 1/10th of a second the



following showcase turns on. Right now here and there show will bring about constant showcase of tally because of industriousness of Vision.

#### 5.3 BLUETOOTH

**Bluetooth** is a technology standard used for exchanging data between fixed and mobile devices over short distances using short-wavelength from 2.400 to 2.485 GHz, and building (PANs). It was originally conceived as a wireless alternative to data cables.



Bluetooth is managed by the (SIG), which has more than 35,000 member companies in the areas of telecommunication, computing, networking, and consumer electronics. standardized Bluetooth as **IEEE 802.15.1**, but no longer maintains the standard. The Bluetooth SIG oversees development of the specification, manages the qualification program, and protects the trademarks. A manufacturer must meet to market it as a Bluetooth device. A network of apply to the technology, which are licensed to individual qualifying devices.

#### 5.4 METAL DETECTOR

A metal **detector** is an that detects the presence of nearby. Metal detectors are useful for finding metal inclusions hidden within objects, or metal objects buried underground. They often consist of a handheld unit with a sensor probe which can be swept over the ground or other objects. If the sensor comes near a piece of metal this is indicated by a changing tone in earphones, or a needle moving on an indicator. Usually the device gives some indication of distance; the closer the metal is, the

higher the tone in the earphone or the higher the needle goes.

## 5.5 ARDUINO UNO R3 MICROCONTROLLER



The Arduino Uno R3 is a microcontroller board based on the ATmega328. It has 14 digital input/output pins (of which 6 can be used as PWM outputs), 6 analog inputs, a 16 MHz crystal oscillator, a USB connection, a power jack, an ICSP header, and a reset button. It contains everything needed to support the microcontroller; simply connect it to a computer with a USB cable or power it with a AC-to-DC adapter or battery to get started

## VI. CONCLUSIONS

In military activities, one of the central difficulties is that the troopers are not ready to speak with control room and in some cases not even with the other fighter. The assurance of the nation is essential strategic officers. Thus, there is concern in regards to the wellbeing for genuine Heroes. A few kinds of instruments have consistently been structured with the coming in innovation to guarantee security and following of officer. Be that as it may, the at least one explanation, all the frameworks may have some disadvantage. Consequently by proposing a versatile remote continuous framework dependent on IoT idea it can straightforwardly associate with the control stay with a most extreme separation. Also, by utilizing Arduino based solid unit it turns out to be less mind boggling and convenient. This

framework can be useful to give the precise area of missing warrior in basic condition and beat the downside of fighters lost without a trace. The proposed framework is additionally useful to improve the correspondence between warrior to officer in crisis circumstance and give appropriate route to control room.

## REFERENCES

- [1] UN, "World Population Aging 2013," 2013, pp. 8–10.
- [2] R. Weinstein, "RFID: A technical overview and its application to the enterprise," *IEEE IT Prof.*, vol. 7, no. 3, pp. 27–33, May/Jun. 2005.
- [3] P. Gope, T. Hwang, "Untraceable Sensor Movement in Distributed IoT Infrastructure," *IEEE Sensors Journal*, Vol. 15 (9), pp. 5340 – 5348, 2015.
- [4] P. Gope, T. Hwang, "A Realistic Lightweight Authentication Protocol Preserving Strong Anonymity for Securing RFID System," *Computers & Security (Elsevier Journal)*, Vol. 55, pp. 271–280, 2015.
- [5] P. Kumar, and H. Lee, "Security Issues in Healthcare Applications Using Wireless Medical Sensor Networks: A Survey." *Sensors (Basel, Switzerland)* 12.1 (2012): pp. 55–91.
- [6] D. Malan, T. F. Jones, M. Welsh, S. Moulton, "CodeBlue: An Ad Hoc Sensor Network Infrastructure for Emergency Medical Care," *Proceedings of the MobiSys2004 Workshop on Applications of Mobile Embedded Systems (WAMES 2004)*; Boston, MA, USA. 6–9 June 2004.
- [7] K. Lorincz, D. J. Malan, T. R. F. Fulford-Jones, A. Nawoj, A. Clavel, V. Shayder, G. Mainland, M. Welsh, "Sensor Networks for Emergency Response: Challenges and Opportunities", *Pervas. Comput.* vol.3, pp.16–23, 2004.

- [8] A. Wood, G. Virone, T. Doan, Q. Cao, L. Selavo, Y. Wu, L. Fang, Z. He , S. Lin, J. Stankovic, "ALARM-NET: Wireless Sensor Networks for Assisted-Living and Residential Monitoring," Department of Computer Science, University of Virginia; Charlottesville, VA, USA: 2006. Technical Report CS-2006-01;
- [9] S. Pai, M. Meingast, T. Roosta, S. Bermudez, S. Wicker, D. K. Mulligan , S. Sastry, "Confidentiality in Sensor Networks: Transactional Information," IEEE Security and Privacy Magazine. 2008
- [10] J.W.P. Ng, B.P.L Lo, O. Wells, M. Sloman, N. Peters, A. Darzi, C. Toumazou, G. Yang, "Ubiquitous Monitoring Environment for Wearable and Implantable Sensors (UbiMon)," Proceedings of 6<sup>th</sup>

