



A REVIEW ON WATER QUALITY MODEL QUAL2K

Praveen savant¹, Dr. Babitha Rani H² and S.Ranjith³.

1 Assistant professor Basava Engineering School of Technology zalaki, vijayapura-586209

2 Professor, Department of Civil Engineering SET - Jain University and

3 Research Student in VTU-PG studies, Belagavi-590018, India.

Abstract: After more than 40 years of imaginative work, the conduit broad water quality model QUAL2K which is organized by the United States Environmental Protection Authority has got lots of achievements in the field of water quality multiplication. Starting late, the QUAL2K model similarly has been comprehensively used by a regularly expanding number of analysts and units in private.

Index Terms – Discharge outlet unit, mass transfer, qual2K, Source unit, Water quality model.

I. INTRODUCTION

The Water pollution is the major problem of the 21st century, water is a vital ingredient for the human being, without water there is no industry, no agriculture, no medicine, no food etc. water will play a significant role in everyone life. The Water we get from rivers, lakes, ponds and wells are polluting day by day. Due to industries, sugar plants, manufacturing plants are polluting the river. The prevention and control of water pollution is a significant challenge nowadays. Water quality models are helping in this situation; one of the models is qual2k is assisting in the protection of the water environment. The other counties are widely using qual2k model for environmental protection, in India, the research scholars have rarely touched it in recent years. This paper will present the history of qual2k model, application of qual2k software, advantages and disadvantages of software, aiming at providing the reference to future research scholars.

History of the development of qual2k

Internationally, water quality models development divided into four stages. The first time Streeter-Phelps established water quality model in 1925. Scientists developed a simple bilinear system model of BOD-DO. It used for river and estuary problems. In stage two, water quality models developed bilinear reduction to six linear models. It consists of computing technology, and the calculation method produced from one dimension to two dimensions. In stage three, a nonlinear system developed; it based on a nutrient nitrogen and phosphorus cyclic reaction system. It also studies the relationship between biomass growth rate and nutrient, sunlight and temperature. In calculation, it will solve by one dimension and two dimension method.

Stage four post- 1975 continuing the studies from step 3 a variety of interaction system have developed it involves the interaction with toxic compounds. It also means three dimensions of spatial scale. However, water quality models become more diversified and simulated, and calculation water environment capacity, water resource allocation and other decisions are dependent on water quality model all these laid constructions of water quality model qual2k.

II. The development of qual2k model

The pollutant components in the previous models were BOD and DO only, but when the pollutant enters into water, it will cause changes in water quality, such as temperature, ammonia nitrogen and algae. Not only BODs and DO. Therefore a new water quality model is needed to describe the water quality correctly. United state environmental protection agency (USEPA), American water resource engineering company with the help of Texas water development department developed a river quality model QUAL in 1970. The model helps in solving the water pollution problems. Subsequently WRE worked with EPA to improve the QUAL model in 1972 and 1976. this version of the model can simulate only 13 water quality components. It gives the range of values in partial differential equation, the model has 23 parameters, in which only 12 of which vary with the river. The settings that do not change with river section it's not necessary to measure. The parameters that change with river section should be measured. In 1987 Brown and Barnwell developed the one- dimensional model QUAL2E. it is the one-dimensional equation of mass transport it can use to various interaction water quality components in a branched river system. Finally, after decades of research and development, the USEPA released the latest version of QUAL2K in 2009.

III. Characteristic and simulation factors of QUAL2K model

Qual2K model as a comprehensive model of water quality, its basic equation is one-dimensional advection-dispersion content transport and reaction equations, which takes into account the responses of water quality components such as water advection-dispersion, dilution and external source import or shift. It has the following settings: (1) One-dimensional, complete vertical and horizontal mixing of the water in the pipe. (2) The flow of water by the river is constant. (3) External variables, such as heat budget, temperature, humidity, wind power and humidity, are all expressed in days, and the internal meteorological equations calculated on the daily time axis. (4) Regular point input and output.

And the new roles of the QUAL2K model are as follows: (1) Carbonaceous BOD speciation. QUAL2K describes organic carbon using two types of carbonaceous BODs. Such types are a continuously oxidizing form (slow CBOD) and an instantly oxidizing form (fast CBOD). (2) The correlation between algae, nutrients, and light has been changed, and new representatives such as algae BOD, anti-nitrification, and various pathogens have been added to the simulation. (3) Ph. It resembles both alkalinity and total inorganic carbon. Based on these two quantities the pH of the river is then determined. (4) Weirs and waterfalls; this particularly involves the hydraulics of weirs as well as the effect of weirs and waterfalls on gas movement. A steady-state current balance is achieved for each model to reach.

$$Q_i = Q_{i-1} + Q_{in,i} - Q_{ab,i} \quad (1)$$

where Q_i = outflow from reach i into the downstream reach $i + 1$ [m^3/d], Q_{i-1} = inflow from the upstream reach $i - 1$ [m^3/d], $Q_{in,i}$ is the total inflow into the reach from point and nonpoint sources [m^3/d], and $Q_{ab,i}$ is the total outflow from the reach due to point and nonpoint abstractions [m^3/d].

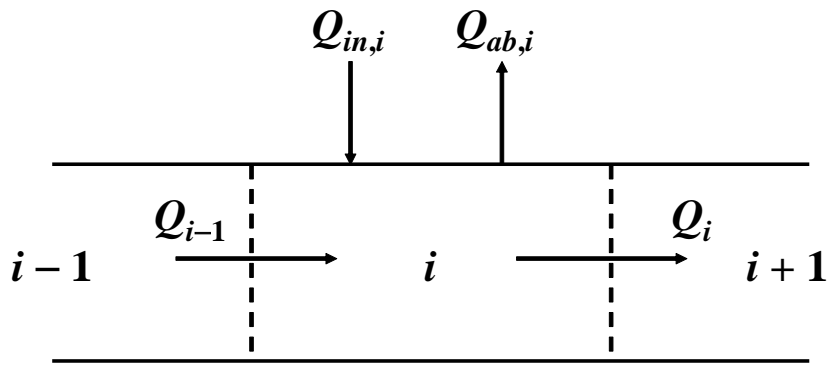

Figure 1 Reach flow balance.

The total inflow from sources is computed as

$$Q_{in,i} = \sum_{j=1}^{psi} Q_{ps,i,j} + \sum_{j=1}^{npsi} Q_{nps,i,j} \tag{2}$$

where $Q_{ps,i,j}$ is the j th point source inflow to reach i [m^3/d], psi = the total number of point sources to reach i , $Q_{nps,i,j}$ is the j th non-point source inflow to reach i [m^3/d], and $npsi$ = the total number of non-point source inflows to reach i .

The total outflow from abstractions is computed as

$$Q_{ab,i} = \sum_{j=1}^{pai} Q_{pa,i,j} + \sum_{j=1}^{npai} Q_{npa,i,j} \tag{3}$$

where $Q_{pa,i,j}$ is the j th point abstraction outflow from reach i [m^3/d], pai = the total number of point abstractions from reach i , $Q_{npa,i,j}$ is the j th non-point abstraction outflow from reach i [m^3/d], and $npai$ = the total number of non-point abstraction flows from reach i .

The non-point sources and abstractions are modeled as line sources. As in Figure 3, the non-point source or abstraction is demarcated by its starting and ending kilometer points. Its flow is distributed to or from each reach in a length-weighted fashion.

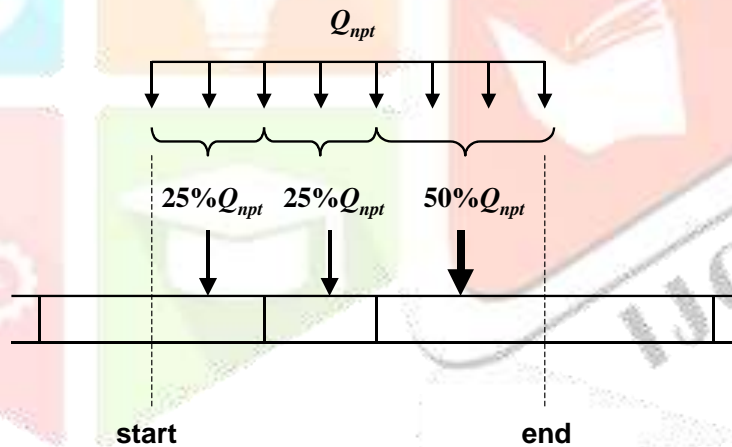

Figure 3 The manner in which non-point source flow is distributed to a reach.

Biochemical oxygen need, dissolved oxygen, temperature, nitrogen, ammonia nitrogen, nitrate nitrogen, organic phosphorus, dissolved phosphorus, E-coli, an elective attenuated radioactive segment, and 3 contrary inertial segments are the comparable problem component of QUAL2K.

Figure 4 shows Model kinetics and mass transfer processes.

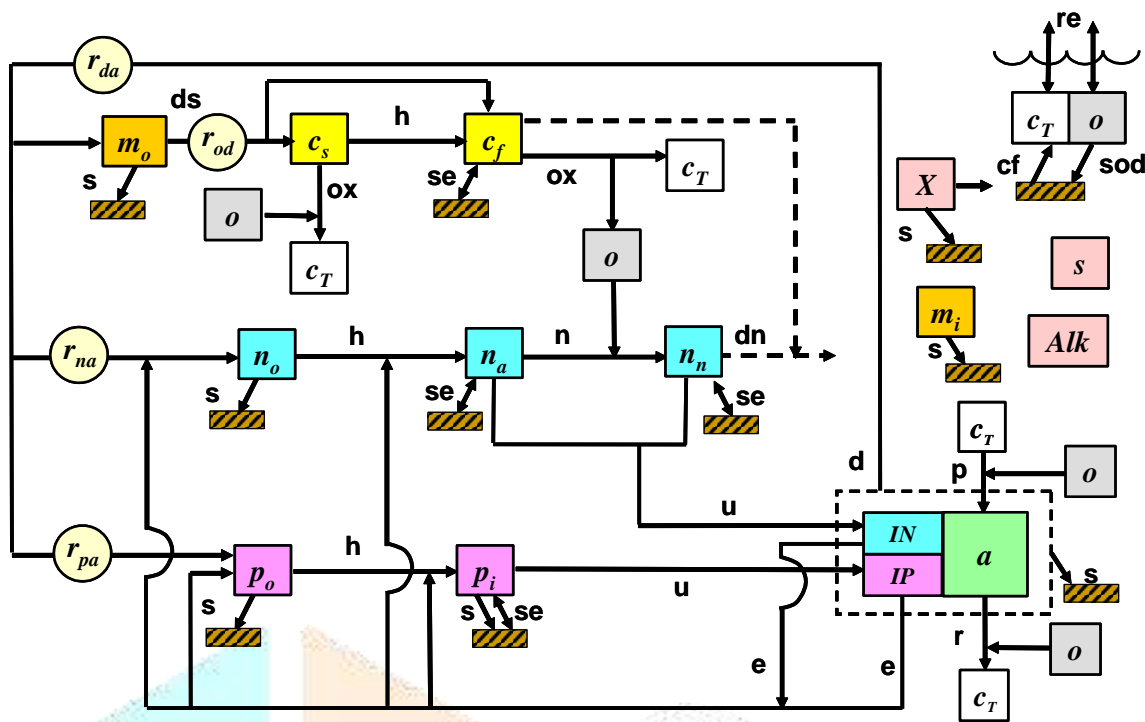
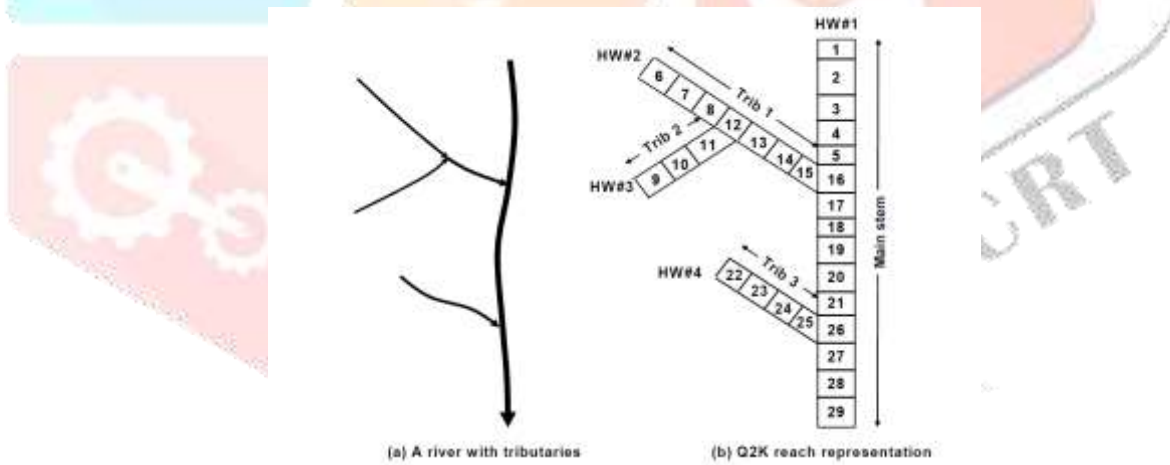

Figure 4 Model kinetics and mass transfer processes. The state variables are defined in **Error! Reference source not found.** Kinetic processes are dissolution (ds), hydrolysis (h), oxidation (ox), nitrification (n), denitrification (dn), photosynthesis (p), respiration (r), excretion (e), death (d), respiration/excretion (rx). Mass transfer processes are reaeration (re), settling (s), sediment oxygen demand (SOD), sediment oxygen exchange (se), and sediment inorganic carbon flux (cf).



VI. QUAL2K model application guide

It first distributes the simulated flow into a series of non-uniform constant flow parts and then distributes each division of the same length into many parts of the scale. The unit is QUAL2K's smallest evaluation unit, and is a typical double reactor for any unit.

QUAL2K determines the unit as eight forms below, to explain the properties of the spatial division of rivers. The Order unit of the model is shown in the table below.

Table 1. Model unit classification

No.	Unit type	definition	Maximum allowable amount
1	Source unit (H)	The source of the main stream and its tributaries	10
2	Junction unit (J)	A tributary import unit	9
3	Upstream unit of junction (U)	The last unit of a junction unit in the mainstream	20
4	System final unit (L)	The last cell in the simulation system	1
5	Intake unit (P)	A unit containing water intake	50
6	Discharge outlet unit (W)	The units containing the emissions	50
7	Hydraulic building unit (D)	A unit containing a hydraulic structure	50
8	Standard unit (S)	All units except the above 7 are defined as standard units	Each river should not exceed 20, and the whole process should not exceed 500.

The model requires many phases of the data that follow. The first is the basin's hydrological data and spatial details such as river basin hydrology and seepage data, river pan pattern and stream flow, stream rate, current rate, river canal section shape, siltation, and so on. The second is, for example, the boundary condition and the point source data: end conditions are the official area boundary, parts are documents, etc. Point source statistics need to examine the origins of technical emissions (factory outlets), the large-scale origins of city life (rain and sewerage pumping stations, drainage systems)[12].

V. Successful application of the QUAL2K models india

In reference [7], the University of Zhejiang used the QUAL2K model and a one-dimensional water quality model in 2009 to resemble the water quality of the Qian Tang River Basin. The paper assesses the ability of COD, ammonia nitrogen and BOD in the entire river basin's water body, and uses the TMDL control model to present research on COD, ammonia nitrogen and BOD load conversion and intensity in the usual river pan areas, providing a prevailing basis for total river pan control amounts. In references [8], Nanchang University applied the QUAL2K model and the one-dimensional model of heavy metal movement and remodel of water quality for perception[12]

According to the water quality properties in the Qinhuai River [9], Hohai University selects DO, NH₃-N and COD as the simulation variables and uses the QUAL2K model to construct the optimum water quality authority model in the Qinhuai River in 2013.

VI. The prospect of QUAL2K model

According to the water quality properties in the Qinhuai River [9], Hohai University selects DO, NH₃-N and COD as the simulation variables and uses the QUAL2K model to form the optimum water quality control model in the Qinhuai River in 2013. The QUAL- II prototype series has been used in many vivid applications of water quality simulation in-stream and stream numbers. The mistake is usually within 20 percent in addition to some river sections. The results of the simulation fit relative well with the real monitoring values. Although the QUAL- II series model has wide application prospects, the implementation and improvement according to the actual situation in China. 1) Extra growth of the software framework and rational software validation indexing method. Based on the QUAL2 K

model's simulation of water quality, optimizing the water environment should first be united with economic and social growth, selecting social economy, resource weather, technology management, and other fields evaluation indicators, and creating a symbol framework with a uniform hierarchical system. So the weight of each index must be calculated and a detailed water-environmental capability assessment model of the river basin must be set. The weight of each index and a detailed evaluation model of the water environment is then calculated. (2) Further investigation is required to select and determine water quality and water-powered parameters. The water quality and hydraulic parameters of the various water bodies in China differ. As for some experimental parameters, if the model is used to provide value, it may be very distinct from the current situation of real streams in China, resulting in low simulation correctness. Considering the model's excessive demand for data volume, the method of the coefficient of importance and the generative algorithm (POMIG) adopted by QUAL2Kw in reference [10] is also a new method of improvement. (3) Coupling further growth with other water quality models and device needs. Reference [11] takes Oklahoma's Dunda basin and west lake basin as examples. The QUAL2E model is executed in the SWAT model to adjust the model's hourly time step effective structure, and then the SCE algorithm is adopted to coordinate and incorporate the water quality target objectives. Finally, statistical methods were used to make the goal collection behave as individual variables to avoid the sway issue, thus improving the SWAT model's water quality simulation ability[12]. This work-related to Kind of have just begun in China and will be one of the trends in the future.

References

- [1]Thompson, J .R., Sorenson, H .R., Gavin, H., et al. (2004) Application of the coupled MIKE SHE and MIKE 11 modeling system to a lowland wet grassland in southeast England [J] Journal of Hydrology, 293(1-4):151-179.
- [2] Banwell, T .O., Brown, L.C., Whittemore, R. C., (2004)Importance of field data in-stream water quality modeling using QUAL2E-UNCAS[J] Journal of Environmental Engineering-ASCE,130(6):643-647.
- [3]Whitehead, P.G., Williams, R. J., Lewis, D.R., (1997) Quality simulation along river systems (QUASAR): model theory and development [J] The Science of the Total Environment, 194 447-456.
- [4] Fu, G. (1987) River water quality mathematics and its numerical calculation [M]. Publishing place: China environmental science press, Beijing.
- [5] Lu, Y., Su, B .L. (2011) Comparison of calculation methods of river pollutant carrying capacity [J] water resources protection, 27 (4):4-10.
- [6] Chen, Z. H., Sun, Y. Li, Z., et al. (2001) River and reservoir water quality models and general software review [J]. Water resources protection, (2):7-11
- [7] Fang, X. B., (2009) Study on water environmental carrying capacity of Qian Tang River Basin [D].Zhejiang University, Hangzhou.
- [8] Huang, X. P., (2005) Lean river water environmental capacity and total amount control study [D].Nanchang University, Hangzhou.
- [9] YANG, L., (2013) Water quality optimization scheme for Qinhuai River based on QUAL2K model [J] water resources protection, 29(3):51-55.

- [10] Niu, L. D., Wang, X .Y. ,(2012) Application of TMDL based WARMF model in water pollution control management [J] water resources protection,28 (3): 20-24
- [11] Lai, G.Y., Wu, D.Y. , Zhong, Y.X.,(2012) Development and application development of SWAT model [J] Journal of hohai university,40 (3): 43-251.
- [12]. Ranjith, S., Shivapur, A.V., Kumar, P.S.K., Hiremath, C.G. and Dhungana, S. (2019) Water Quality Model for Streams: A Review. Journal of Environmental Protection, 10, 1612-1648. <https://doi.org/10.4236/jep.2019.1012097>

