



# INTERNATIONAL JOURNAL OF CREATIVE RESEARCH THOUGHTS (IJCRT)

An International Open Access, Peer-reviewed, Refereed Journal

## Application of Servo Motor - Strategy to Avoid the Wastage of Consumable Energy

N. Mullai Rajan<sup>1</sup>  
B.E. Electrical and  
Electronics Engineering  
SNS College of Technology  
Coimbatore  
India

S.V. Subadevi<sup>2</sup>  
B.E. Electrical and  
Electronics Engineering  
SNS College of Technology  
Coimbatore  
India

K.S. Madanraj<sup>3</sup>  
B.E. Electrical and  
Communication Engineering  
SNS College of Technology  
Coimbatore  
India

S.Gowtham<sup>4</sup>  
B.E. Electrical and Communication  
Engineering  
SNS College of Technology, Coimbatore  
India

S.S. Hariharan<sup>5</sup>  
B.E. Electrical and Communication  
Engineering  
SNS College of Technology Coimbatore  
India

**Abstract:** Solar power produces 1 kWh (1,000 watts) in a day per 250-watt panel. If you multiply 1kWh per panel by 30 days in a month, you'll find that each 250 watt rated panel will produce about 30 kWh in an average month. The International Energy Agency projected in 2014 that under its "high-renewable" scenario, by 2050, solar photo voltaic and concentrated solar power would contribute about 16 and 11 percent, respectively, of the worldwide electricity consumption, and solar would be the world's largest source of electricity. In 2017, solar power provided 1.7% of total worldwide electricity production, growing 35% from the previous year. As of 2018, the subsidize livelier for utility-scale solar power is around \$43/M Wh. These clearly depicts the important of 'Solar Power Plants' the problem is the production of the energy is only high during the 'noon' time during the 'Dawn and 'Dusk' the production is small in scale, to overcome this and to be efficient, we came up with an

idea using LDRs and a Servo Motor, using in which high intensity angle of the Sun beam can be detected using R Pi, then the Servo motor can be triggered to deviate the Panel.

**Keyword :** Solar Panel, High renewable source, Dawn and Dusk, LDRs, Servo Motor, Angle of Sunbeam, R Pi.

### 1. PROBLEM STATEMENT:

#### 1.1 Wastage of consumable power

The power production from the Sun light has become the major source of electricity in industrial areas since the cost of solar panels have fallen by last decade. Many industrialized nations have installed significant solar power capacity to their grids. Importantly, usage of solar cells will reduce the long distance power lines for transmissions. Technologies of producing electricity from Solar beam namely 'Photo Voltaic (PV)[fig 1.1] and Concentrated solar power(CSP)[fig 1.2].

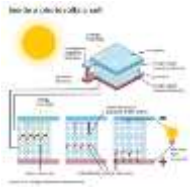

Fig 1.1 .

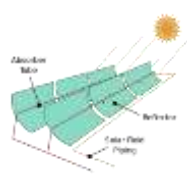

Fig 1.2

In both the technologies PV, CSP the production rate is high only during Noon. During the Dawn and Dusk the altitude of the sunbeam won't fall on the Panel intensively. During in which the production is too low. The production and consumption of electricity in a Day is given in Fig 1.3. This Shows the wastage of consumable solar during Dawn and Dusk.

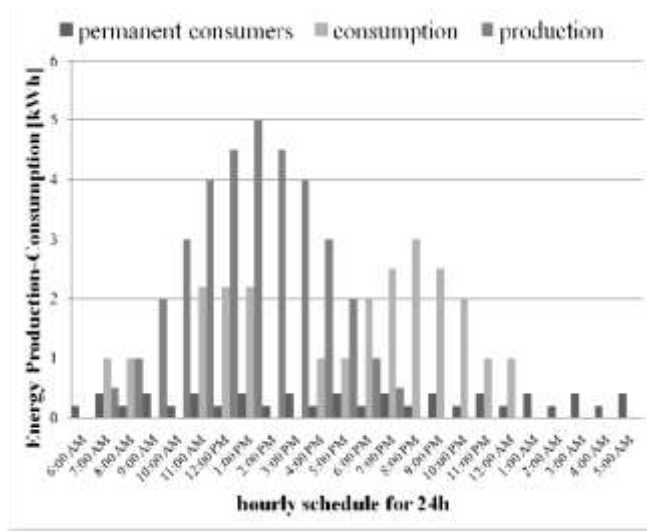

Fig 1.3

1.2 Low production when the requirement is high.

Most of the civilians will be at home only during the evening time, results in the high consumption of electricity

From the graph, it's clear that the 'consumption rate' is at peak during the Evening time(6 p.m TO 11 p.m) but due to the low altitude of the sunbeam the production rate is too little, due to the mismatched magnitude of Production and Consumption, the battery backup may exhaust. Civilians or industries may face discomfort due to this course.

1.3 Excessive production and Grid Drop.

Between 11 a.m to 5 p.m, the 'excess power' [the difference between available power and required power] is too high, Excess electricity production makes the voltage on the grid rise. Electricity shortage makes the voltage on the grid drop.

II. SYSTEM OVERVIEW

The system between the 'Solar Panel Array' and 'Grid' need not be discussed in this paper. Our entire system is at the Solar panel, the basic requirement of the system is the Number of LDRs(fig 2.1(a)) as per the desire of Customers expected Accuracy. Indeed, four LDRs were enough for the process. For Tilting the Solar Panel ' AC Servo Motor's(fig 2.2(a)) was recommended due to the phenomenon of good speed control characteristics, smooth control in the entire speed range, almost no oscillation, high efficiency, low heat generation, high-speed control, high precision position control.



Fig 2.1(a)



Fig 2.2(a)

Raspberry Pi(fig 2.3) system can be used for its Huge processing power in a compact board.



Fig 2.3

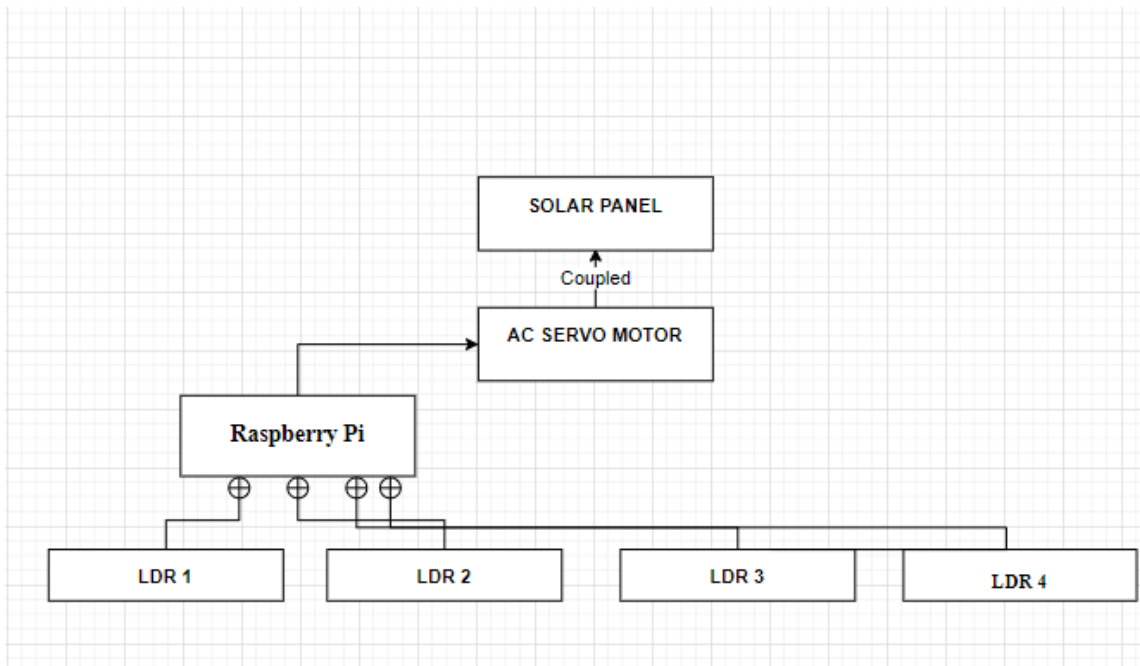

Fig 2.4 ( System Block Diagram )

## 2.1 LDR

A photo-resistor or light dependent resistor is a component that is sensitive to light. When light falls on it then the resistance changes. The values of the resistance of the LDR may change over many orders of magnitude the value of the resistance falling as the level of light increases.

Using this phenomenon of the LDR the brighter side of the Environment can be detected using raspberry pi (python programming). As we mentioned earlier Four or more LDRs can be used based on the required Accuracy.

The resistance between LDR will be measured from the Raspberry Pie, then the 'un-balanced' output from the LDRs will trigger the 'AC Servo Motor' to run. As per Fig 2.1, (b) the Capacitor's (1 $\mu$ f) anode is connected to R PI pin 11(GPIO17) and cathode are to R Pi pin 6 (GND). The Photo resistor or LDR's anode terminal connected to series with capacitor's anode along to the R Pi Pin 11(GPIO17) and the cathode terminal of the LDR is connected to the R Pi 13(GPIO27) [based on the R Pi capacitors can be replaced with resistors]

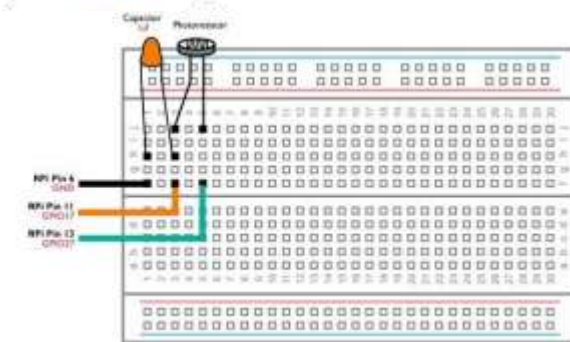

Fig 2.1(b)

## 2.2 AC Servo Motor

The High-Starting Torque of the AC Servo Motor is the most important character that's why we should go with AC Servo Motors.

The AC Servo Motor is coupled with Solar Panel, using 'Gears' as shown in fig 2.2(b). AC Servo Motor is made with Plastic gears, but for this application it requires 'Metal gears' for strength. The output starting torque can be as much as 20 times higher than a cheaper plastic one.



Fig 2.2(b)

Whenever the Raspberry pie triggers the servo motors, the Motor will spin till the the Four LDR's resistance readings balances with each other.

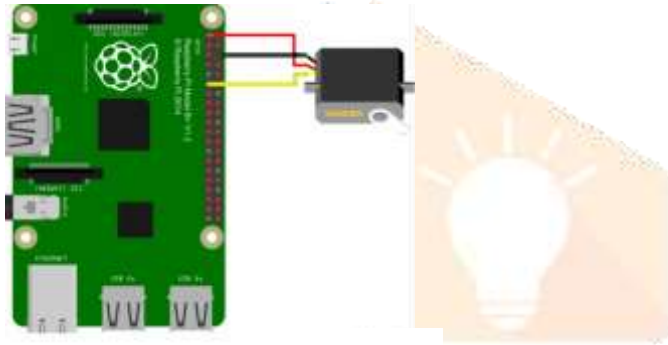

Fig 2.2(c)

The three terminals (Black, Red, Yellow) of the AC Servo Motor will be connected to the Raspberry pie. The Black terminal of the AC Servo motor is connected to the R Pi Pin 6(GND), then red to the R Pi Pin 1(3V3) and the Yellow/Orange terminal is connected to the R Pi Pin 11(GPIO17).

### 2.3 Raspberry Pie

As we mentioned above the number of LDRs and the AC servo Motor is Connected to the R Pi.

Two LDRs(ldr 1 & ldr 2) will be on a side(either east or west) and rest of LDRs(ldr 3 & ldr 4) will be on the other side(either east or west) of the Solar Panel. The two sides from the four sides of the panels can be determined by Sun rising and setting Direction, for the purpose of tilting.

The python Program can be dumped into the Raspberry Pie, the algorithm should be like “*The LDRs*

*reading should be taken in every ten minutes, whenever there is a un-balanced resistance reading from the LDRs the AC Servo Motors should be triggered till the resistive reading of the LDR Balances. Then, if the ldr1 and ldr 2 receive high light then the resistance will be low in ldr 1 & ldr 2, in this case, the AC Servo motor should rotate in Clockwise direction. If the ldr 3 & ldr 4 receives high light the resistance will be low, in this case, the AC Servo Motor should rotate in Anti-Clock wise.”*

That is how the Spinning or Tilting process is done.

### III. Operation of Detecting and tilting

#### 3.1. Detection System

The Detection System, consists of LDRs as two sets namely ‘ldr set a’(ldr 1 & ldr 2) and ‘ldr set b’(ldr 3 & ldr 4), each set will be connected in ‘series’ so the low resistive side can be described as the brighter side using code.

#### 3.2. Rotation System

If the *set* receives high resistance, probably the time will be Morning. During the Evening time vice verse of the morning detected data. As per the data received the panel will spin either clock-wise or anti-clock wise accordingly using the AC Servo Motor.

### IV. Schematic setup

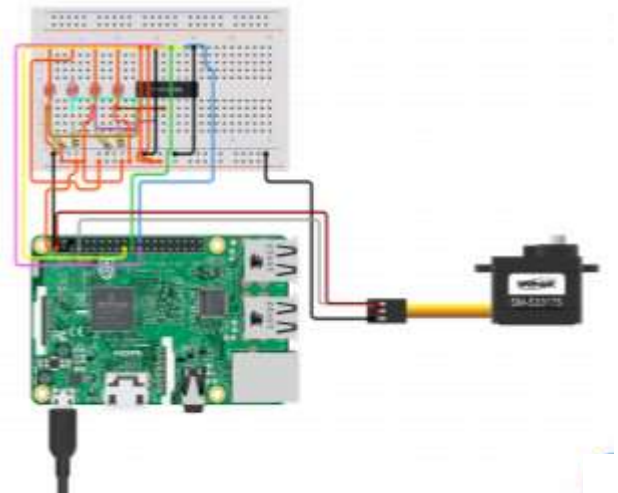

Fig 4 - Schematic setup for the System



## V. Experimental setup

LDRs are the base of the system. The entire experimental setup is based on the contents mentioned in the 'III. Operation of Detecting and tilting'. To make the R Pi understand the time more clearly, since during the evening and morning both the sets of LDRs will receive the high resistance, to eradicate this issue 'small metal sheet is welded on both the sides of the panel to improve the accuracy of the tilting.

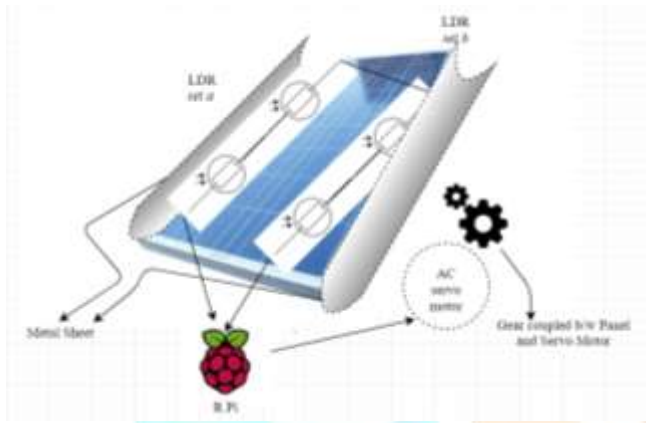

Fig 5 The experimental setup of the system

## VI. Result

### VIII. Future Work

#### 7.1. Excessive power and Grid drop

Though the major problems can be solved using our 'project', still there is a *problem* which is left unratified, the Excessive power production during the noon hours. This can be solved using *555 IC timer* or *IOT*. In *phase 02* of this paper we will discuss vastly this phenomenon.

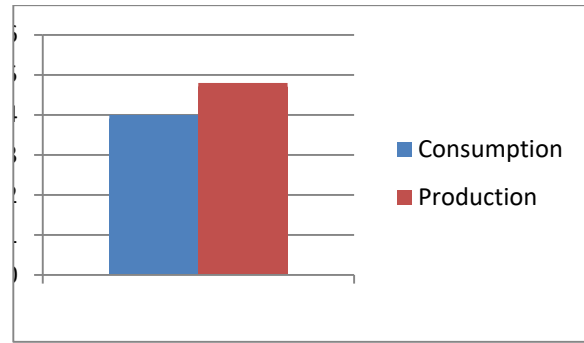

Fig 6.1

From the graph (fig 6.1) it's clear that the '*production*' rate is increased when it is compared with the existing output.

## VII. Conclusion

This Innovative project will sort out all the problem statements which we mentioned early except the 'Grid Drop', the ratification of this problem will be discussed in the *phase 02*.

Due to the standard production of power even in the evening, it will reduce the risk factor of 'power off'. Since this method helps the panel to produce more energy to the grid. The high production rate from the early morning will minimize the 'loop supply'.

### 7.2. APP Based.

In some cases, people may want to get information about the solar panel system they own. As advancement in our system, the user could get information from their palmtop using an application. The *production rate* and *consumption rate* can be monitored by the user from remote places.