



# DOUBLE BOOST RESONANT CONVERTER

<sup>1</sup> Ms.S.Priyadharshini, <sup>2</sup> Mrs.M.Nathiya, <sup>3</sup> Mr.C.Mathan

<sup>1</sup> Assistant Professor, <sup>2</sup> Assistant Professor, <sup>3</sup> Assistant Professor

<sup>1</sup> Electronics and instrumentation Engineering,

<sup>1</sup> Mahendra Engineering College, Namakkal, India

## Abstract

A new high efficiency resonant boost converter is introduced. Topology is a hybrid circuit between a switched resonator and a switched-capacitor converter. The voltage gain is adjustable and full range zero current switching operation is given for switches independent of operating voltages and load capacity. The structure is built without any additional switch in the circuit by an inverter arm. All high frequency resonant types are passive components, and then small size realization is possible. Stability of the converter is assured.

**Keywords:** High frequency, Small size, Voltage gain

## I. INTRODUCTION

The conversion of step-up voltage is main function that is very much required in many circuits. The basic pulse width modulated (PWM) boost converter employs the advantages of ease of operation and control. Its hard-switching operation, however reduces conversion efficiency and increases the levels of electromagnetic interference induced. In addition, the high power density demanded in modern electronic systems cannot be managed to achieve by hard-switching operations.

A new family of DC-DC converter for soft-switching resonant is proposed in [4]. The topologies suggested only one switch, two diodes, and one resonant LC tank with high frequency. Zero voltage switching (ZVS) condition is given for the switch, thereby dramatically enhancing the converter power density and performance.

Hybrid boost converter (HBC) is designed [15] with combined benefits of regulation capability from its boost structure and gain enhancement from its voltage multiplier structure. The converter is designed with single inductor and single switch thereby providing high capability gain and reduced component stress. These features make it suitable for renewable energy applications.

The new converter features a bipolar voltage multiplier with symmetrical configuration, single inductor and single switch, high gain capacity with wide range of control, low part tension. Nevertheless, components including an active switch, are needed to generate the necessary voltage gain. It is not only important to use many switches; each switch also requires a floating gate driver. In most structures derived from SC such as ladder, series-parallel, and doubler, this problem is general. The step-up cells are formed by diodes and capacitor in the converter provided in [11] and the active switch is not used. The converter component, however, is a full bridge system that needs four switches. The diode placed between input and output terminals distinguish the common ground more significantly. An interesting simple resonant boost circuit is recommended which restricts its voltage gain to 2.

DC-DC boost soft switching converter is proposed, the soft switching methods reduces the output power losses thereby the efficiency of the converter is improved. The auxiliary circuit is located out of the main power path preventing the switches from voltage stress and current stress.

An optimized DC-DC voltage doubler based on resonant switched capacitor topology is proposed in [16] which make use of the less weight PCB type and miniature components makes the converter to increase efficiency by decreasing the losses. The use of parasitic resistance makes the voltage gain drop when power rises, that limits the rated power.

The efficiency and performance of the converter is decreased by the charging and discharging modes of the capacitor. Thus, a new

model is created by the adding a resonant inductor. The performance of the converter is improved by the soft- switching conditions.

The stress caused by the hard switching across the switches and diodes is the major difficulty faced in the conventional boost converter. The losses across the switches reduces the efficiency of the converter. In order to improve the efficiency of the flyback converter it is always suggested to use high frequency transformer. In Grid connected systems, converter with high frequency transformer is preferred for better efficiency purposes. The use of high frequency transformer increases the risk of complexity in designing the circuits. In other way, to increase the voltage gain switched capacitor is used. This can be given as, the required switched capacitor directly proportional to the desired voltage gain. . Even though, the voltage gain is increased, it leads to increased losses and complexity in designing the circuits. Thereby reducing the losses caused by hard switching, a converter which operates in resonant condition was designed. Soft switching can be achieved in resonant converters with the use of LC tank elements circuits.

The main drawback in SSC is the spiky currents created during the charging and discharging of the capacitor, thus gradually reduces the efficiency of the converter.

To overcome this drawback, a small resonant inductor is used along with the capacitor which operates at zero current switching (ZCS). This is termed as resonant switched capacitor converter (RSC). The performance of the converter can be greatly enhanced by the soft-switching operating mode. The voltage of both the converter (RSC) and (SCC) is not adjustable. The new modelled switched resonant converter (SwRC) can effectively adjust the output voltage gain along with the characteristics of RSC.

Though the PWM boost converter is simple to operate and easy to control, its hard-switching operation reduces the efficiency and give raise to increased electromagnetic interference. As, there is no use of magnetic element in switched capacitor converter (SCC) is mostly used in low power ON chip applications.

## II. PROPOSED CONVERTER

Resonant tank circuits consists of  $L_a$  and  $C_a$ . The voltage of the capacitor  $C_a$  is called as resonant voltage  $V_a$  and the current of  $L_a$  is resonant current  $i_a$ . The diode  $D_s$  is placed in series with the unidirectional switch  $D_{a2}$ .

In steady state condition, the equivalent circuits of the different stages are illustrated as shown below. Initially, consider the voltage and current of the capacitor and inductor is zero. If the frequency increases, the dead time will also change and the output voltage will be decreased. The voltage gain also increased and the voltage output voltage remained constant.

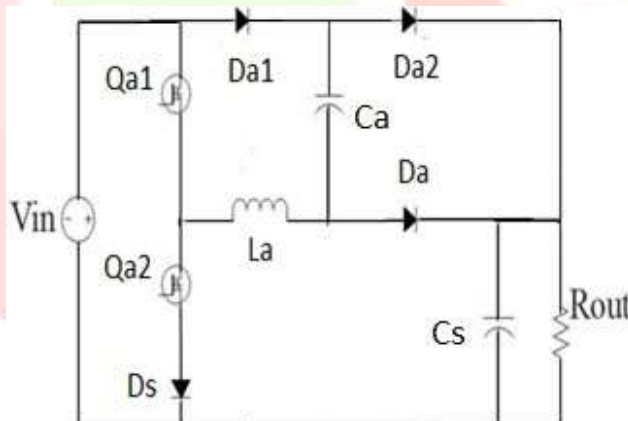

Fig. 1 Proposed step-up converter

Stage 1 : The Switch  $Q_{a2}$  is turned ON initially, the diodes  $D_{a1}$  and  $D_a$  becomes forward biased and all other diodes are at OFF condition. The resonant current ( $i_a$ ) and voltage ( $V_a$ ) waveforms is in sinusoidal manner because of the resonant network created by  $L_a$  and  $C_a$ . Thus, the switches are turned ON at zero current switching condition. The switched  $Q_{a2}$  is turned OFF when the resonant current reaches zero.

Stage 2 : In this stage , the switch  $Q_{a1}$  is turned ON at ZCS and the charging of the output side capacitor by  $i_a$  , creates the sinusoidal waveforms.

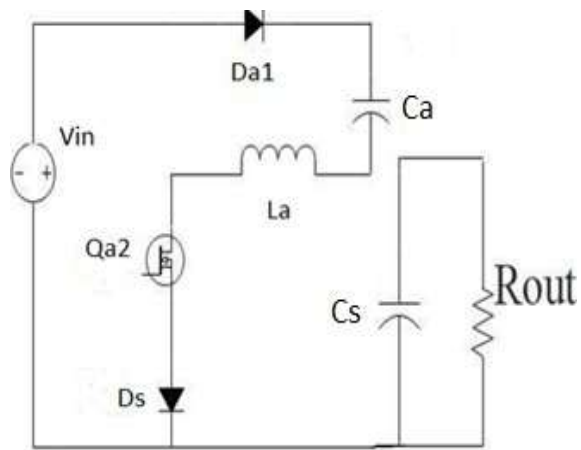

Fig. 2 Equivalent circuits of operating stage 1

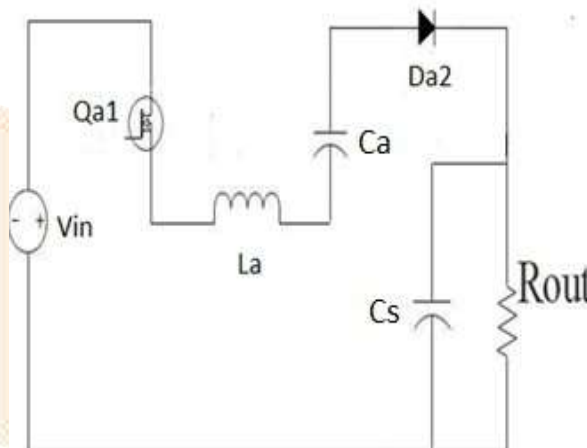

Fig. 3 Equivalent circuits of operating stage 2

Stage 3 : In this stage, the voltage  $v_a$  across the capacitor is zero, hence at ZVS condition the diode  $D_a$  is turned ON. The magnitude of the current  $i_a$  decreases linearly and the magnetic energy stored in the inductor  $L_a$  is delivered to the output. Thereby the current  $i_a$  reduces zero at this stage and the switch  $Q_{a1}$  is turned OFF at ZCS.

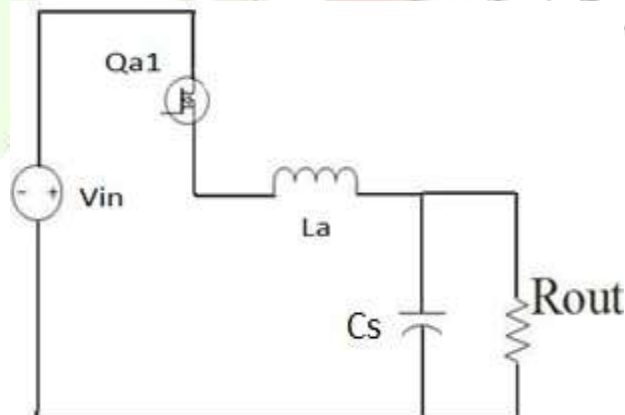

Fig. 4 Equivalent circuits of operating stage 3

Stage 4 : All the devices are OFF in this condition. The output capacitor provides the supply to the load. The voltage gain of the converter can be controlled by the duration of this mode.

$$i_a(t) = 0$$

$$v_a(t) = 0$$

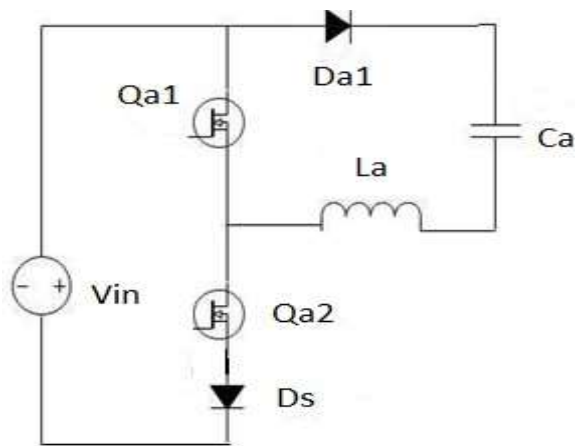

Fig. 5 Equivalent circuits of operating stage 4

### III. STEADY-STATE MODELLING

At steady state condition, DC voltage gain  $G$  is obtained by eliminating the power losses. Two requirements are considered for the stresses of voltage. Next, it is stated that all devices are ideal. The output capacitance of all switching devices is taken into account in the second condition. Instead, together with  $L_a$  or parasitic / stray inductances, this capacitance produces oscillations that place additional voltage stress on the unit.

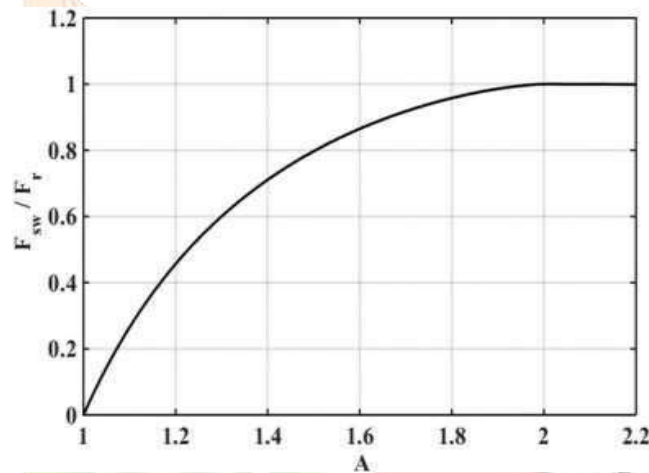

Fig. 6 Switching frequency versus voltage gain

### IV. SIMULATION

The figure shows the simulation diagram of the open loop double boost resonant converter. The components are taken from the library Simulink library and the values are in accordance with the proposed design values.

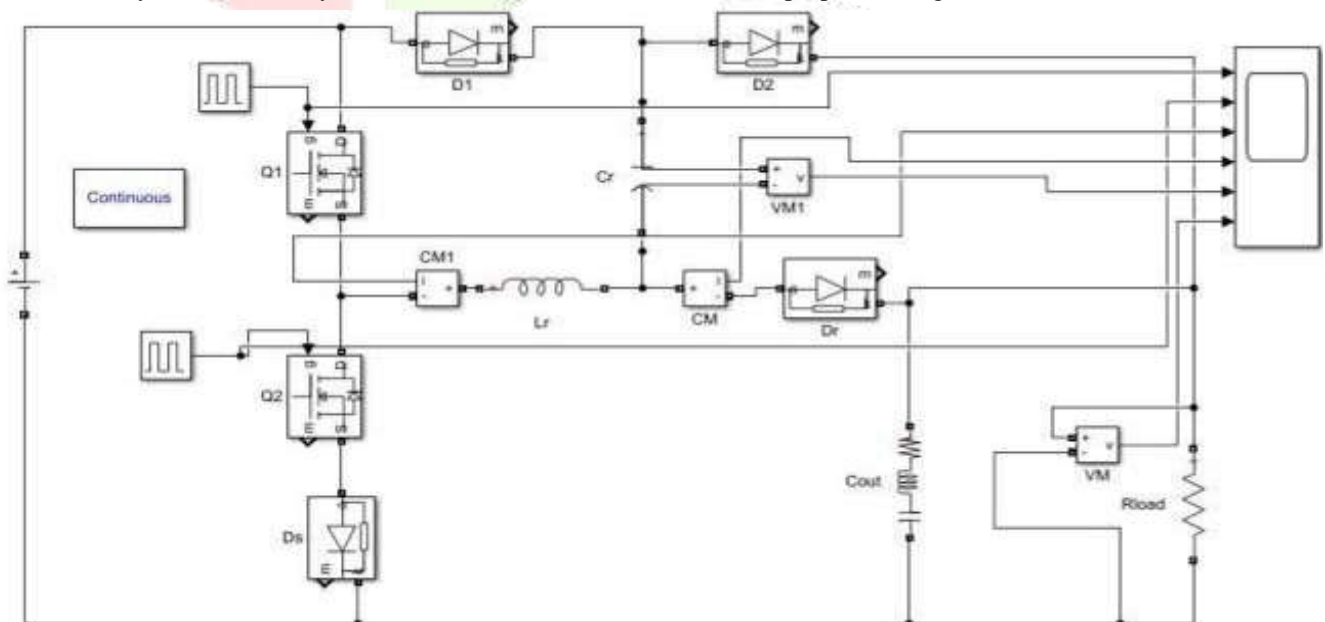

Fig. 7 Simulation diagram of the open loop

## V. SIMULATION PARAMETER

The parameter values of the resistor, inductor, capacitor and voltage source are given as the specification of the proposed system design.

$$V_{in} = 24 \text{ V}, R_{out} = 22 \text{ ohm}$$

$$L_a = 11.6 \mu\text{H}, C_a = 220 \text{ nf}, C_s = 33 \text{ nf}$$

Then the circuit's key parameter is to give pulse generator values. Pulse Generator 1 provides the Q a1 switching pulse and the Qa2 switching pulse generator 2. The pulse generator 1 runs on a time-based basis and uses simulation time. The parameter values are specified as

$$\text{Amplitude} = 5 \text{ v}, \text{Period} = 12.5 \times 10^{-6}$$

$$\text{Pulse width} = 60.3424\%, \text{Phase delay} = 5 \times 10^{-6}$$

The pulse generator 2 runs on a time-based basis and uses simulation time. The parameter values are specified as

$$\text{Amplitude} = 5 \text{ v}, \text{Period} = 12.5 \times 10^{-6}$$

$$\text{Pulse width} = 36.3775\%, \text{Phase delay} = 0.5 \times 10^{-6}$$

## VI. SIMULATION FOR CLOSED LOOP SYSTEM

The figure represents the simulation diagram of the closed loop system dependent double boost switched resonant converter.

Fig.8 Simulation diagram of the closed loop system

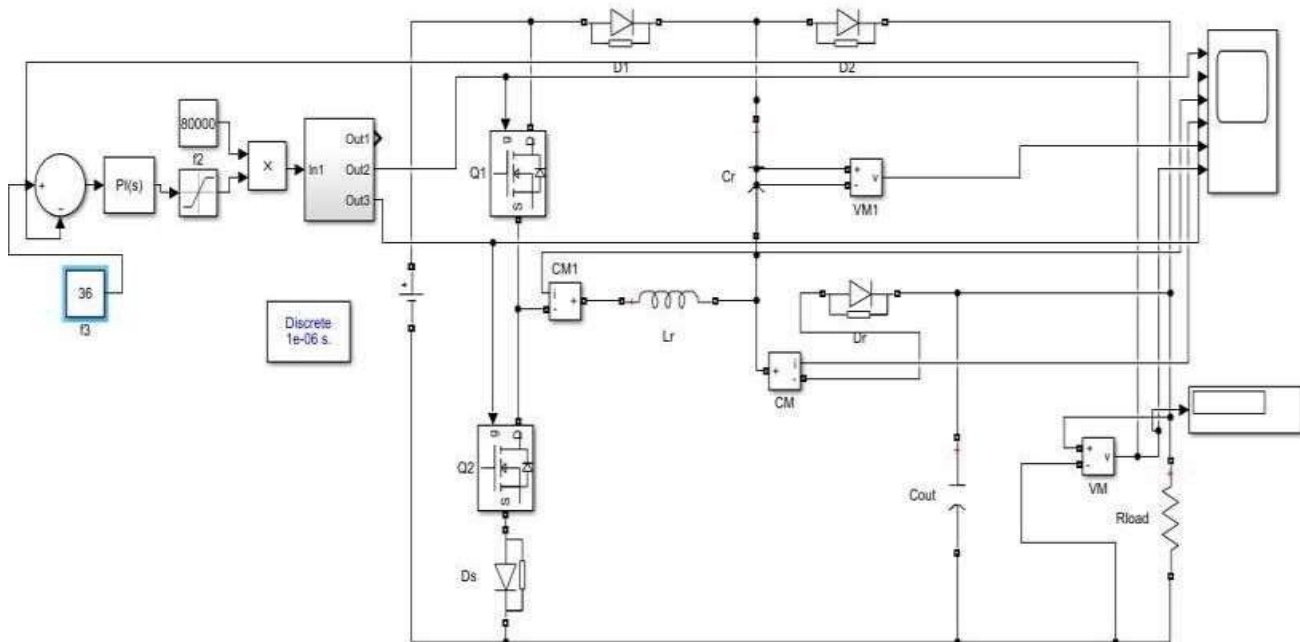

The components are taken from the Simulink library, the values are based on the design values of the proposed, and the subsystems are designed based on the derived formulas.

## VII. SIMULATION OUTPUT OF OPEN LOOP SYSTEM

The figure shows the waveform of the dual boost resonant converter Qa1 and Qa2 alternating pulse open loop simulation. Here the Qa1 has more ON than the Qa2 pulse and there is dead time when both were switched off.

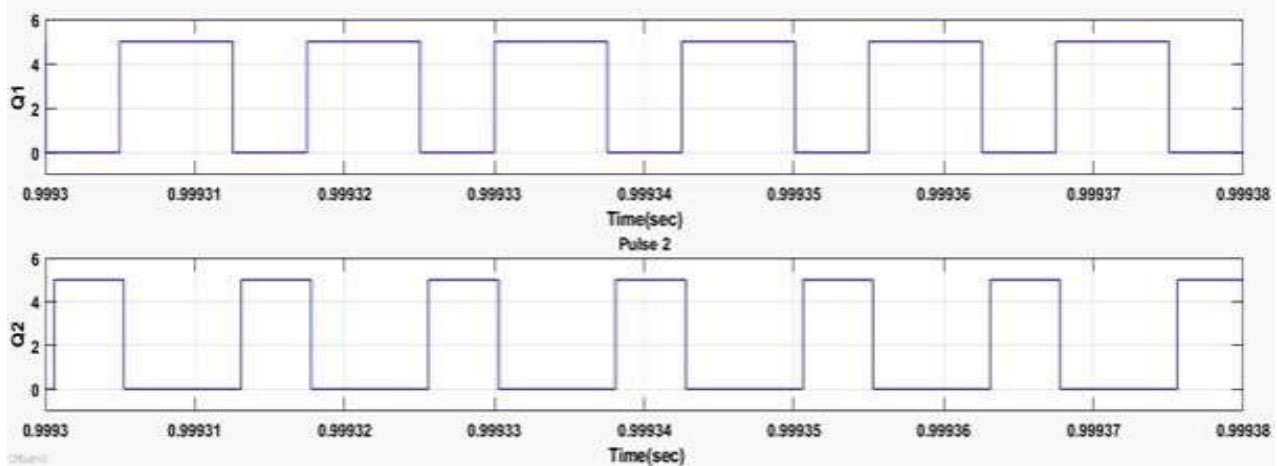

Fig. 9 Pulse waveform of the switches

The figure shows the waveform of the double boost resonant converter's inductor current. The current ranges between positive and negative, indicating the current flow in both directions.

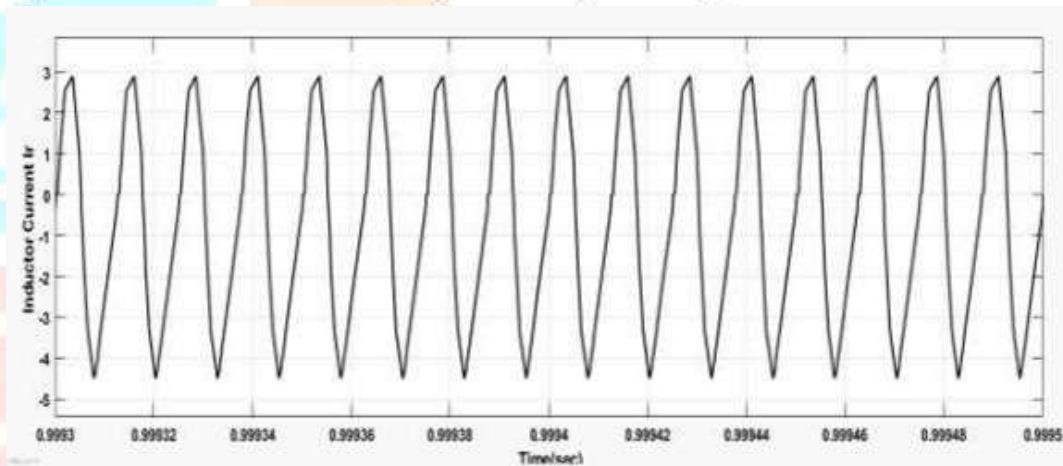

Fig.10 Inductor current waveform

The figure shows the waveform of capacitor voltage. The voltage ranges from positive to negative, demonstrating the capacitor's charge and discharge.

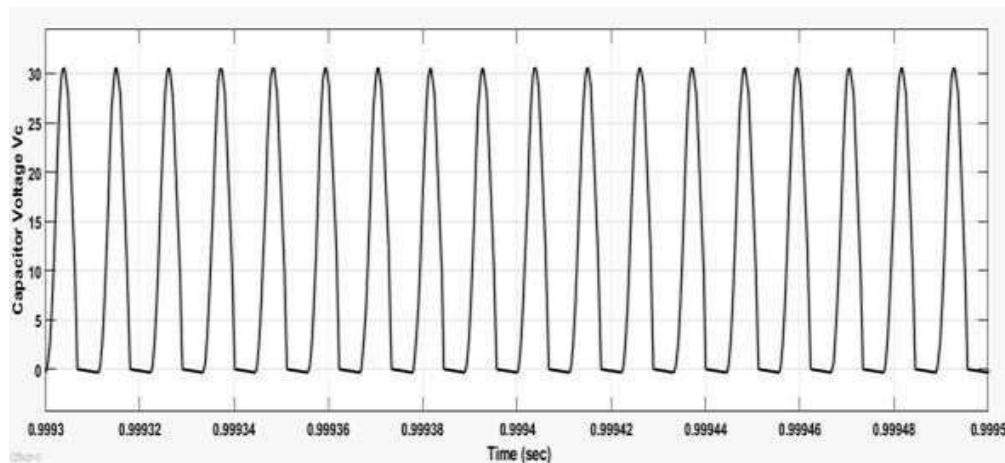

Fig.11 Waveform of capacitor voltage

The figure shows the output waveform of diode current. It varies depending on the different modes of supply throughout the diode.

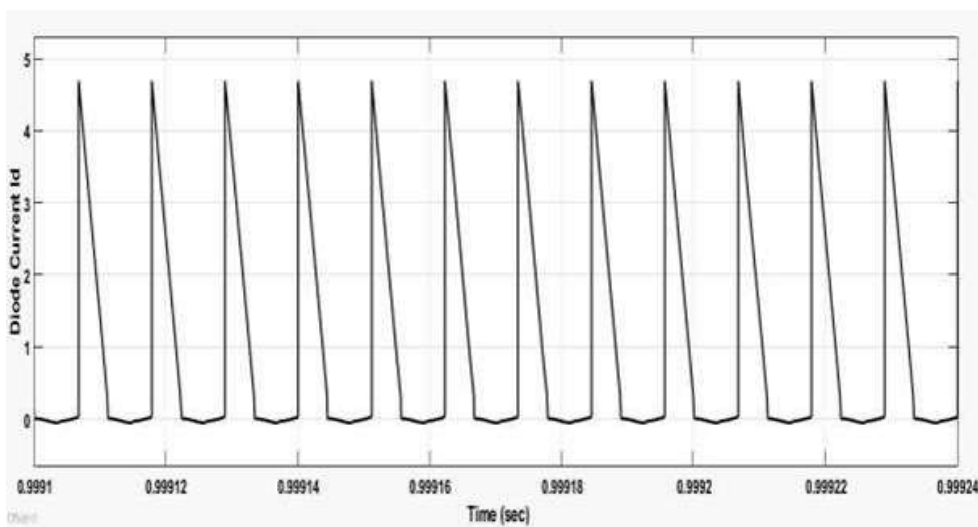

Fig.12 Diode current waveform

The figure shows the output voltage of resonant converter where the input voltage is enhanced by the measurements of the system.

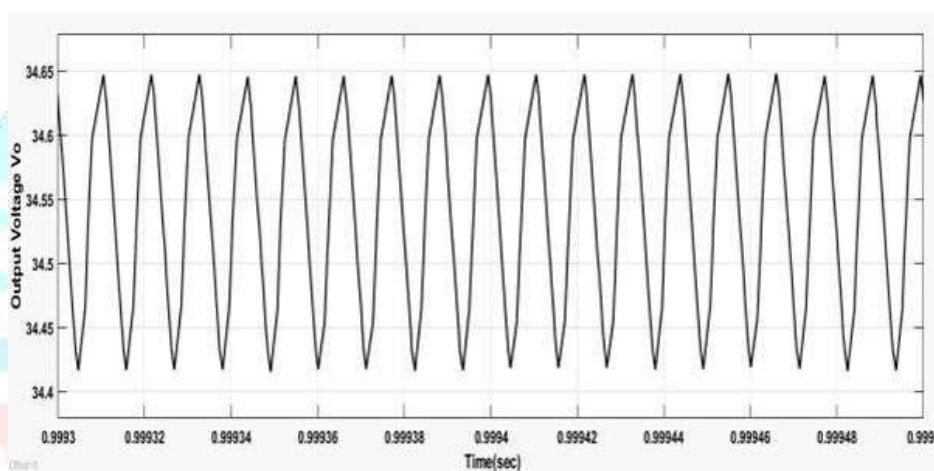

Fig.13 Output voltage waveform

### VIII. SIMULATION OUTPUT OF CLOSED LOOP SYSTEM

The figure shows the output waveform of the double boost resonant converter's inductor current. The current ranges between positive and negative, indicating the current flow in both directions.

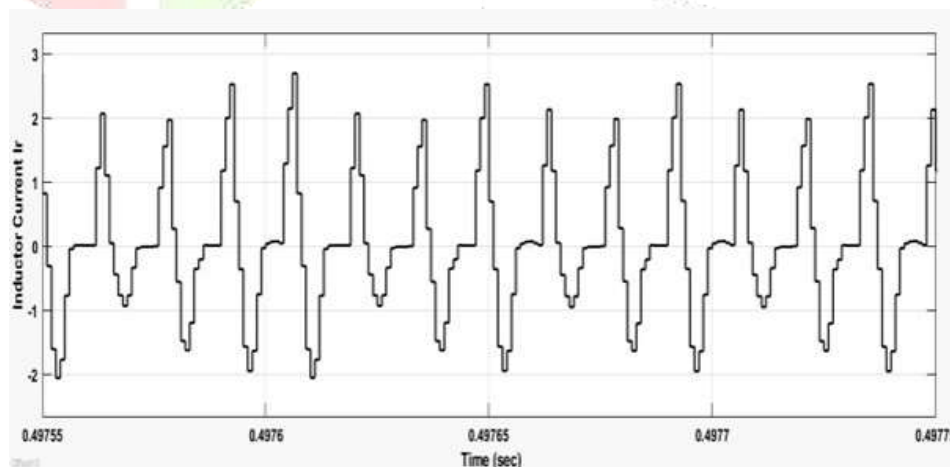

Fig.14 Inductor current waveform

The figure shows the output waveform of the double boost resonant converter's capacitor voltage. The voltage ranges from positive to negative, demonstrating the capacitor's charge and discharge.

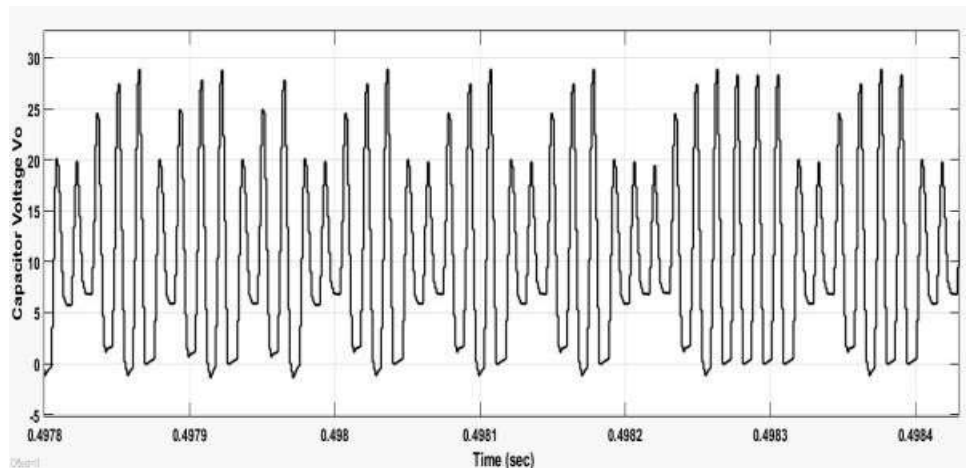

Fig.15 Capacitor voltage waveform

The figure shows the output voltage of resonant converter.

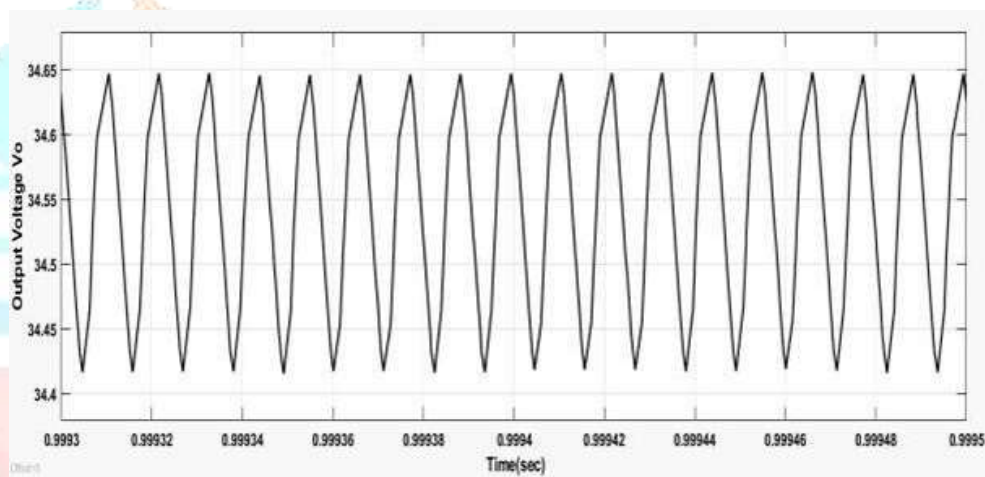

Fig.16 Output voltage waveform

## IX. RESULT

A new SCC and SwRC-based hybrid step-up resonant converter are developed. The advantages includes adjustability of voltage gain, operation of maximum soft switching, high efficiency and small size. Theoretical analysis is presented in accordance with simulation tests.



**REFERENCE**

- [1] Martins, M., Perdigão, M.S., Mendes, A.M.S., *et al.*: ‘Analysis, design and experimentation of a dimmable resonant-switched-capacitor LED driver with inductor control’, *IEEE Trans. Power Electron.*, 2017, 32, (4), pp. 3051–3062.
- [2] Y. Panov and M. M. Jovanovic, “Performance Evaluation of 70-W TwoStage Adaptors for Notebook Computers,” in *Proc. IEEE APEC*, 1999, pp. 10591065.
- [3] Chong-Eun Ki and Jae-Il Baek “High-Efficiency Single-Stage LLC Resonant Converter for Wide-Input- Voltage Range” *IEEE Trans. Power Electron.*, vol. 32, no. 1, pp. 433-440, Jan 2018.
- [4] S. W. Choi, B. W. Ryu, and G. W. Moon, “Two- Stage AC/DC Converter Employing Load-Adaptive Link-Voltage-Adjusting Technique with Load Power Estimator for Notebook Computer Adaptor,” in *Proc. IEEE ECCE*, 2009, pp. 3761-3767.
- [5] Jabbari, M., Farzanehfard, H.: ‘Family of soft switching resonant DC-DC converters’, *IET Power Electron.*, 2009, 2, (2), pp. 113–124.
- [6] Ivensky, G., Zeltser, I., Kats, A., *et al.*: ‘Reducing IGBT losses in ZCS series resonant converters’, *IEEE Trans. Ind. Electron.*, 1999, 46, (1), pp. 67– 74.
- [7] Kim, S.-J., Do, H.-L.: ‘Soft-switching step-up converter with ripple-free output current’, *IEEE Trans. Power Electron.*, 2016, 31, (8), pp. 5618–5624.
- [8] Ye, Y., Cheng, K.W.E.: ‘Analysis and optimization of switched capacitor power conversion circuits with parasitic resistances and inductances’, *IEEE Trans. Power Electron.*, 2017, 32, (3), pp. 2018–2028.
- [9] Abraham, C., Roslind Jose, B., Mathew, J., *et al.*: ‘Modelling, simulation and experimental investigation of a new two input, series-parallel switched capacitor converter’, *IET Power Electron.*, 2017, 10, (3), pp. 368– 376.
- [10] Y. C. Chuang and Y. L. Ke, “High-efficiency battery charger with a buck zero-current-switching pulse-width-modulated converter,” *IET Power Electron.*, vol.1, no.4, pp433-444, Dec.2008.
- [11] D. Y. Kim, C. E. Kim, and G. W. Moon, “High- efficiency slim adapter with low-profile transformer structure,” *IEEE Trans. Ind. Electron.*, vol. 59, no. 9, pp. 3445-3449, Sep. 2012.
- [12] Tahavorgar, A., Quaicoe, J.E.: ‘A dual series- resonant DC–DC converter’, *IEEE Trans. Power Electron*, 2016, 32, (5), pp. 3708–3718.
- [13] Mohan, N., Undeland, T.M., Robbins, W.P.: ‘Power electronics: converters, applications, and design’ (Wiley, New York, 2002, 3rd edn.).
- [14] Wu, B., Li, S., Lio, Y., *et al.*: ‘A new hybrid boosting converter for renewable energy applications’, *IEEE Trans. Power Electron.*, 2016, 31, (2), pp. 1203–1215.
- [15] Mondzik, A., Waradzyn, Z., Stala, R., *et al.*: ‘High efficiency switched capacitor voltage doubler with planar core-based resonant choke’. *CPEPOWERENG*, 10th Int. Conf., Bydgoszcz, Poland, June 2016, pp. 402– 4efhurhri