



SEISMIC RESPONSE REDUCTION FACTOR FOR RC ELEVATED METRO STATIONS

¹Rasha Attia Ahmed Attia, ²Reham Mohamed Galal Ebrahim El-Tahawy, ³Mohamed Nour El-Din Fayed

¹Teacher Assistant, ²Associate Professor, ³Professor

^{1, 2 & 3} Structural Department,

^{1, 2 & 3} Ain Shams University, Cairo, Egypt

Abstract: The response reduction/modification factor (R) is defined as an essential seismic design tool, usually used to specify the in-elasticity expected level in structure during earthquakes. The concept of response reduction/modification factor (R) depends on the observations that well detailed seismic framing systems can maintain large in-elastic deformations without collapse. When a RC structure is subjected to the lateral loads, a base shear, which is prominently higher than the actual structure response, is created. Thus, it possesses a significant amount of over-strength or reserve strength. Over-strength is developed because maximum lateral strength of any RC structure always exceeds its design strength. Once it enters the inelastic phase, it is capable of resisting and absorbing a large amount of seismic energy. Hence, seismic codes introduce a reduction in design loads, taking benefit of the fact that the structure possesses over-strength and ductility as per Asgarian and Shokrgozar (2009). This force reduction factor is called Response Reduction/Modification Factor (R). Furthermore, the aim of this research is to investigate the variation of seismic response of special RC structures with different configurations, such as elevated metro stations. Consequently, the response reduction factor can be evaluated. Then the calculated response reduction/modification factors (R) for reinforced concrete (RC) structures will be compared to those specified in ECP [11] and the ASCE code [7]. For this purpose, a three dimensional Finite Element Method was used for modelling the RC structure using ABAQUS V.6.14 program [1].

Index Terms - Ductility Factor, Over strength Factor, Pushover analysis, Reduction Modification Factor, Time history analysis

I. INTRODUCTION

Earthquake engineering has developed as a branch of engineering concerned with the estimation of earthquake impacts, since last few decades. It has become an interdisciplinary subject involving seismologists, structural engineer, geotechnical engineers, architects, urban planners, information technologists and social scientists. In the past few years, the earthquake engineering community has been reassessing its procedures, in the wake of devastating earthquakes which have caused extensive damage, loss of life and property. These procedures involve assessment of seismic force demands on the structure and then developing design procedures for the structure to withstand the applied actions [1].

II. LITERATURE REVIEW

A summary of previous available work was conducted on different fields like response reduction/modification factor (R), displacement ductility capacity, ductility, pushover and time history for this study is presented as follows.

- In 2016, Bholebhavi [2] modeled RC SMRF with medium rise that have irregularity in elevation, vertical irregularity and in Plan irregularities to evaluate the (R) factor for irregular RC structures using the non-linear static analysis. The results explained that as percentage of horizontal irregularities increases R-value decreases, as a percentage of sudden vertical irregularities increases, R-value was decreasing and a structure with gradual irregularities in elevation didn't show considerable deviation in R-value.
- Toby, Kottuppillil et al. (2015) [3] modeled two reinforced concrete (RC) frames types, (SMRF) & (OMRF) with a constant number of bays and number of stories (regular RC frame and soft storied frame), mass irregular frame and geometric irregular frames. The results explained that both (SMRF) and (OMRF) failed to reach the target values of response reduction/modification factor (R) recommended by Indian standards code (IS).
- In 2014, Hakim [4] aimed to investigate building performance on resisting expected seismic loadings. Two 3D reinforced concrete (RC) frames were analyzed using the push-over analysis following (ATC-40). One was designed based on a design practice which takes in account only gravity load and other frame was designed based on Saudi Building Code (SBC-301) [5]. The results explained that the RC structure designed considering only gravity load was found not sufficient. While, the RC frame designed based on (SBC 301) satisfies Immediate Occupancy (IO) acceptance criteria following (ATC-40).

- AdeelZafar et al. (2009) [1] modeled two prototype RC structures with varying geometric characteristics to estimate the (R) factor for the RC frames in Pakistan. This research included a different analysis including incremental dynamic analysis and inelastic static pushover. Seven natural records of EQ were selected. The input accelerograms were scaled up starting from the lowest intensity until the ultimate limit state was reached. This study explained that the analysis of the proposed (R) factor in seismic codes, which is being adopted in Pakistan, gives a false representation of the structure response during EQs. Also the results explained that a single value of (R) factor as mentioned in BCP2007 (UBC 97)[6] or the NESPAK2006 become un-conservative by up to 11% and 22%, respectively.
- In 2008, Asgarian and Shokrgozar [7] evaluated response reduction/modification factor(R), over-strength and the ductility of buckling-restrained braced frames. Seismic building codes considered a decrease in design loads; considering that, the RC structures have substantial over-strength and the capacity of energy dissipation. The ductility and over-strength were included in design through a reduction/modification factor(R). The basic fault in code actions was using linear methods not considering nonlinear behavior. Over strength in RC structures is connected to the fact that, maximum lateral strength of a RC structure usually beats its design strength. It was perceived that the response reduction/modification factor(R) decreases as the building height increases.

III. RESPONSEMODIFICATION FACTOR

The response reduction/modification factor(R) is a measure of the over strength and ductility for any RC structure in inelastic phase. It also can be expressed as a function of different parameters of RC structural system, as ductility, strength, damping and redundancy as per ATC-19 [8&9].

$$R = R_s R_\mu R_R R_\xi \tag{1}$$

Where (R_s) is the over-strength factor, (R_μ) is the ductility factor, (R_ξ) is the damping factor.

- The over-strength factor (R_s) is defined in ASCE 7(2008) by the ratio between the ultimate load (V_u) and design load (V_d), where the design lateral load equal 60% of the ultimate capacity (V_u) to satisfy the requirement for the system to remain elastic as suggested by Uang (1991) [10]. Design displacement (Δ_d) is defined as the displacement corresponding to the design load.
- (R_μ) is the ductility factor is a function of μ , for short, intermediate and long period structures is presented below in equation (2) as suggested by Newmark and Hall (1982) [11]:

Short period	$T < 0.2$ seconds $R_\mu = 1$
Intermediate period	$0.2 < T < 0.5$ seconds
	$R_\mu = (2\mu - 1)^{0.5}$ (2)
Long period	$T > 0.5$ seconds $R_\mu = \mu$

- (R_ξ) is the damping factor balances the effect of supplementary viscous damping and is mainly applicable in case of structures with additional energy dissipating devices. In the absence of such devices, the damping factor is generally assumed as 1.0.
- (R_R) is the redundancy factor depends on the number of vertical elements participating in seismic resistance and can be assumed as unity following the ASCE7 guidelines.

Fig. 1 illustrate relationship between force reduction factor(R), over-strength factor (R_s) and ductility factor R_μ ; taking R_ξ & $R_R = 1$

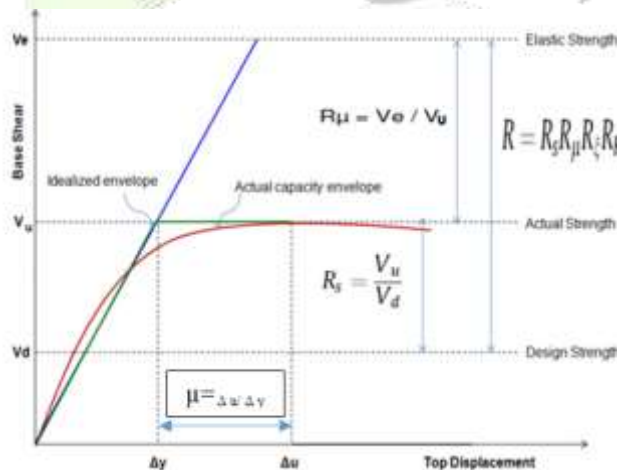

Fig. 1. Relationship between force reduction/modification factor (R), over-strength factor (R_s) and ductility factor (R_μ)

IV. RESPONSEPARAMETERS

Evaluation of deformation quantities Δ_{ult} and Δ_y from action-deformation relationships is not always straightforward. Park (1988) define the ultimate and yield deformation based on force deformation relationship to quantify the global ductility of RC structural systems. The definitions for yield and ultimate deformation are shown in following sections.

4.1. Yield Deformations

Yield points in RC buildings are usually not well defined due to of nonlinearities associated with concrete cracking and plastic hinges formation in beams and columns. Different definitions for yield deformations have been proposed as summarized below (Park, 1988):

- A- Deformation corresponding to first yield. See Fig. 2.
- B- Deformation corresponding to the yield point of an equivalent elasto-plastic system with the same elastic stiffness and ultimate load as the real system. See Fig. 3.
- C- Deformation corresponding to the yield point of an equivalent elasto-plastic system with the same energy absorption as the real system. See Fig. 4.
- D- Deformation corresponding to the yield point of an equivalent elasto-plastic system with reduced stiffness computed as the secant stiffness at 75% of the ultimate lateral load of the real system. See Fig. 5.

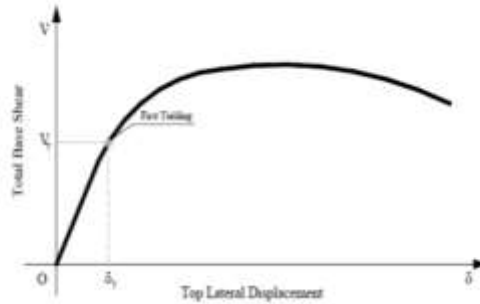

Fig. 2. Definitions of yield deformation, corresponding to first yield (Park, 1988).

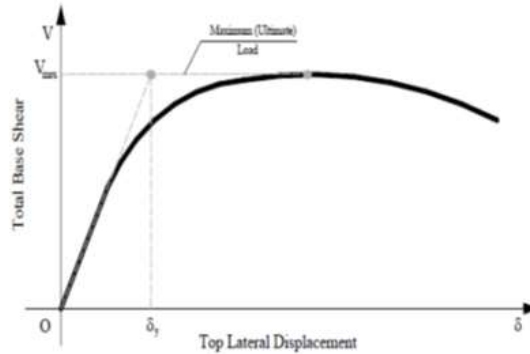

Fig. 3. Definitions of yield deformation, based on equivalent elasto-plastic yield (Park, 1988).

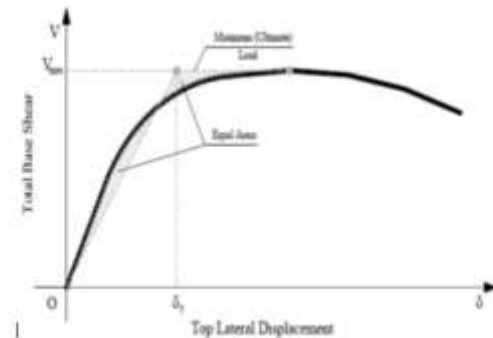

Fig. 4. Definitions of yield deformation, based on equivalent elasto-plastic energy absorption (Park, 1988).

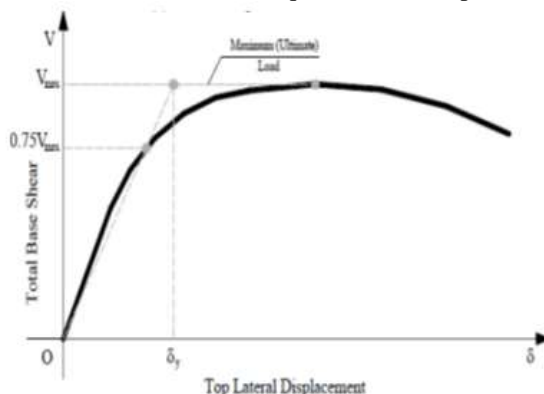

Fig. 5. Definitions of yield deformation, based on reduced stiffness equivalent elasto-plastic yield (Park, 1988).

4.2. Ultimate Deformations

The definitions for ultimate deformations are as follows (Park, 1988):

A- Deformation with respect to a limited value of strain. See Fig. 6.

B- Deformation with respect to the relationship between load and displacement. See Fig. 7.

C- Deformation with respect to post peak displacement when the load carrying capacity has undergone a small reduction(almost 20% strength degradation).See Fig. 8.

D- Deformation with respect to buckling or fracture. See Fig. 9. Ductile structures usually have post peak load strength and their load displacement curves don't exhibit reduction in resistance.

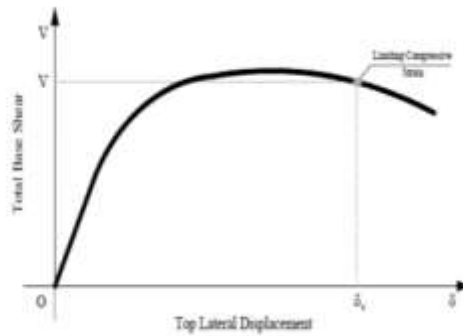

Fig. 6. Definitions of ultimate deformation, based on limiting compressive strain (Park, 1988).

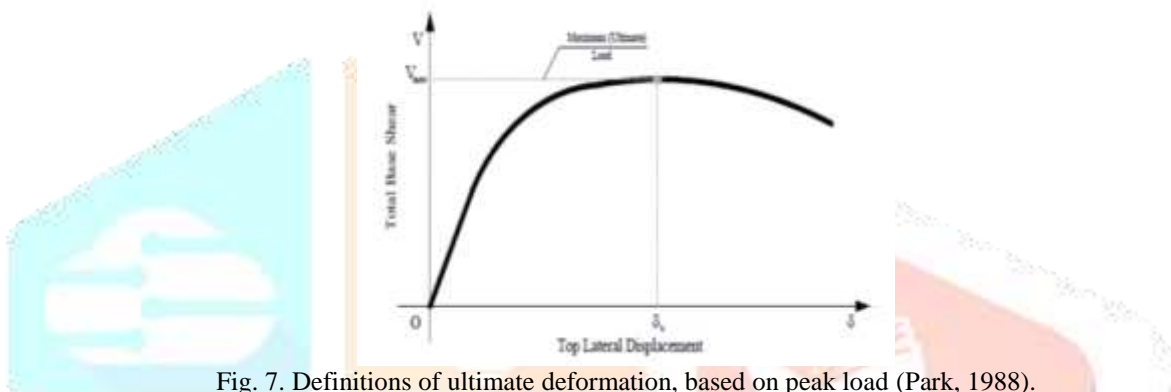

Fig. 7. Definitions of ultimate deformation, based on peak load (Park, 1988).

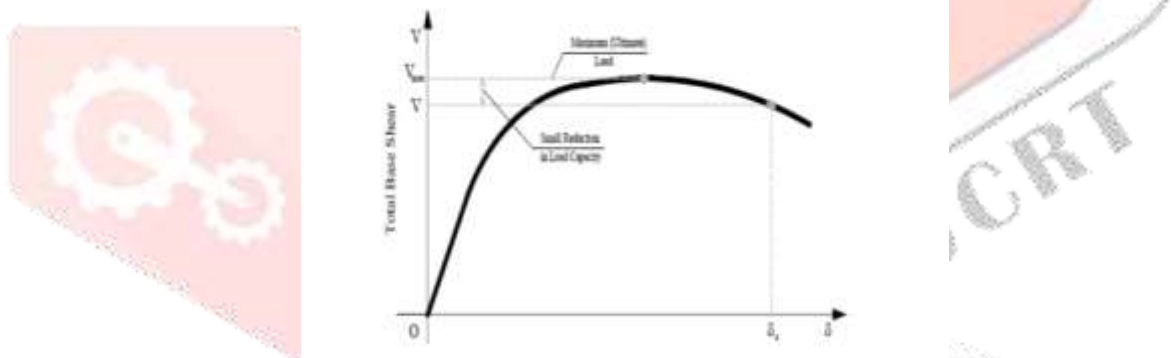

Fig. 8. Definitions of ultimate deformation, based on significant Load capacity after peak load (Park, 1988).

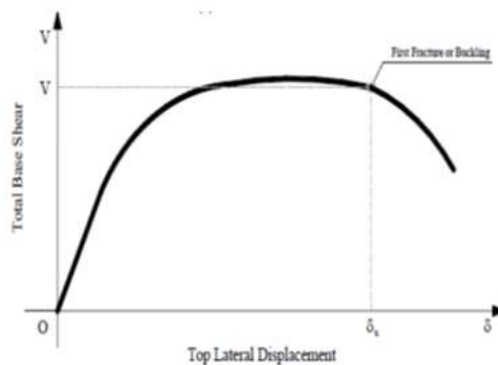

Fig. 9. Definitions of ultimate deformation, based on fracture and/or buckling (Park, 1988).

4.3. Elastic–Perfectly-Plasticidealization Curve Used In The Study

The evaluation of deformation quantities Δ_y and Δ_{ult} isn't always straightforward. The definition of yield and ultimate deformation can be applied on both nonlinear time history curve and pushover curve.

- For yield displacement the most realistic method is the one considered in Fig. 4 since it can be applied in general to structures of concrete.
- For max displacement it should be recognized that most structures have the ability to deform peak load without significant reduction in strength so it will be reasonable to consider the post peak deformations in calculating of ductility. Also, it is evident that maximum available deformations dose not necessary correspond to a specified compressive strain at extreme outer fiber (R.Park and T.Paulay).Consequently, for the max displacement definition most realistic method is considered in Fig. 7.

V. ANALYSIS METHODS

The two common methods of non-linear analysis are non-linear time history analysis and non-linear static analysis. For both methods, RC framing systems are modelled and analysed as an assembly of components and elements.

5.1. Pushover Analysis

Non-linear static push-over analysis is considered to be a powerful tool to assess capacity of RC structure and so, it is able to predict the actual behaviour of reinforced concrete structure during EQ.

Push-over analysis is a static, nonlinear procedure to analyse seismic performance of a RC building where the software model of RC structure is laterally pushed until a specified displacement is attained or a collapse has occurred. The loading is increased in increments with a specific pre-defined pattern (such as uniform or inverted triangular pattern). The gravity load is kept as a constant during analysis. RC structure is pushed until plastic hinges are formed such that a curve between base shear and corresponding roof displacement can be developed. The ultimate base shear that RC structure can resist and its corresponding lateral displacement can be found out from the Push-over curve. Lateral Load Distribution and a Typical Pushover Curve is illustrated in Fig. 10.

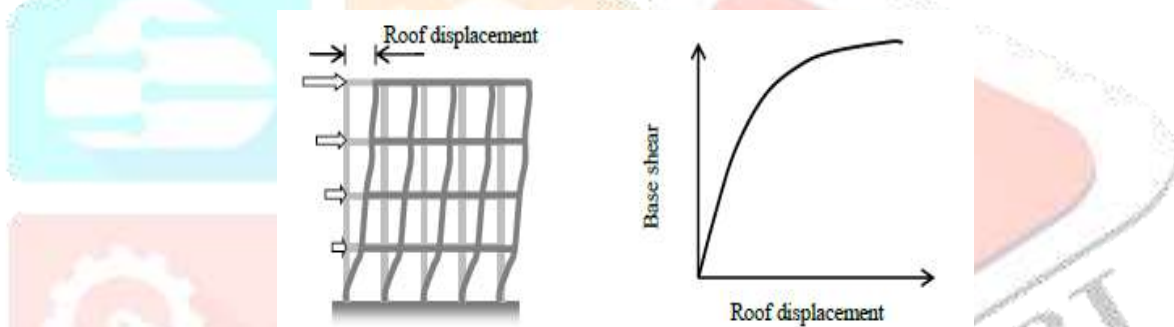

Fig. 10. Distribution of Lateral Load and a Typical Pushover Curve.

5.2. Time History Analysis

The time history analysis of reinforced concrete structures has been used for a quite long time for research. Considering the advantage of time-history analysis relative to equivalent static load method. Time history analysis is the most realistic procedure for computing seismic demands but requires much computational effort, time and cost, current civil engineering practice prefers to use time history analysis pushover analysis in accordance to FEMA 365 document. Dynamic analysis of RC structures is extensively used in research at universities. Until recently, it has not been used in practical seismic design or evaluations of buildings. However, recent editions of building codes around the world demonstrate the use of time-history analysis in design of specified types of RC buildings located in seismic regions (e.g. ASCE 2006, European Committee for Standardization(2004), Standards New Zealand 2004). Conducting time-history analysis in ABAQUS, the earthquake input motions

should be applied at the bedrock horizontally propagating upward through the entire model. For dynamic inputs with high frequency the stability requirements may necessitate a very fine spatial mesh and a corresponding small time step which may lead to a prohibitively time and memory consuming analysis. For such cases, where most of the power for the input history is contained in lower-frequency components, it is possible to adjust the input by filtering the history and removing high frequency components. Fig. 11 show the relationship between acceleration and time period.

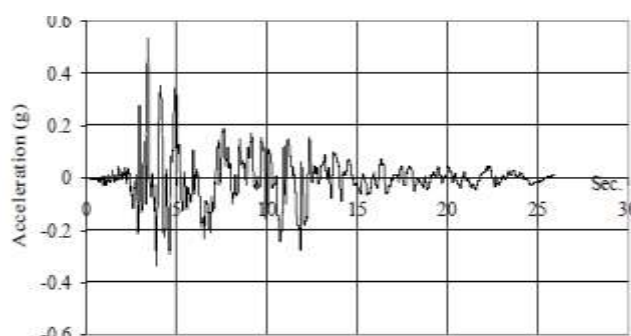

Fig. 11. The relation between time period and acceleration

A series of low, medium, and high frequency earthquakes were selected for nonlinear dynamic analyses. With reference PEER database (PEER 2006)[21], time history of selected EQs are illustrated in Fig. 12.

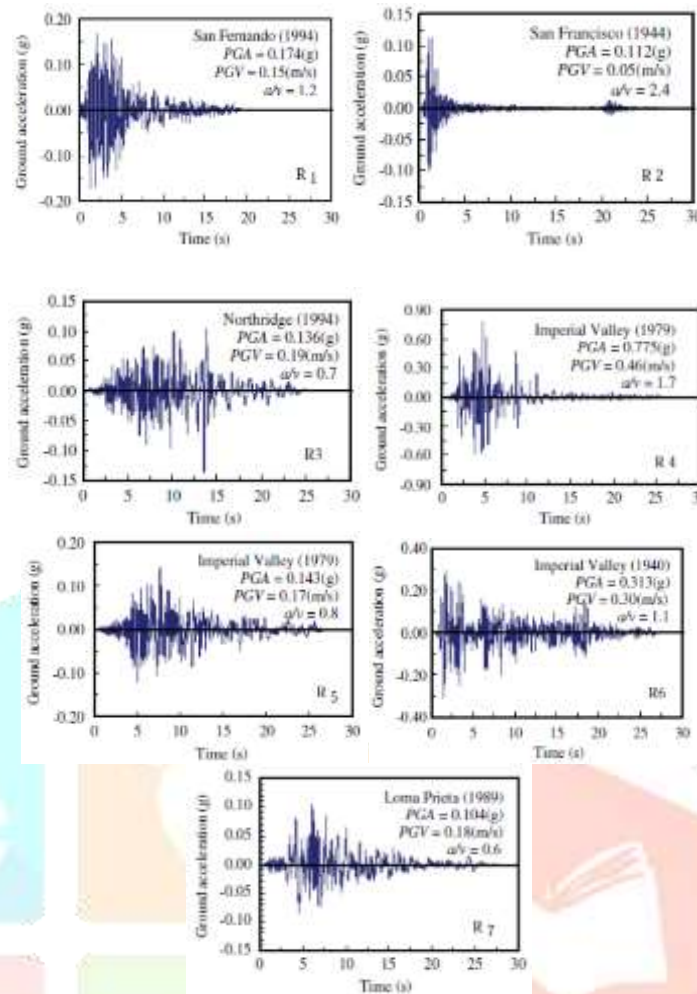

Fig. 12: Time history of selected ground motions

A comparison between time history curves for selected ground motions and ECP response spectrum curves for different soil types is shown in Fig. 13, which shows that the selected ground motions are compatible with the ECP response spectrum.

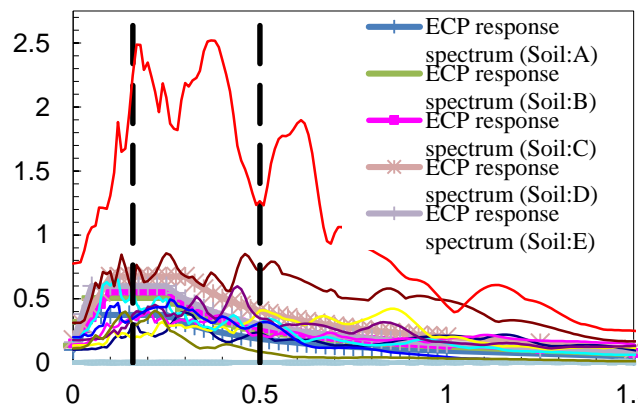

Fig. 13: Scaled response spectrum of the selected ground motions

VI. NON LINEAR NUMERICAL MODEL FOR RC STRUCTURES

6.1. Element Model

Finite element software package ABAQUS V.6.14[12] was used in this study to conduct a fully coupled analysis of the entire elevated metro stations supported on piled foundations system, a three-dimensional numerical soil-structure model has been developed in this study which treats the behaviours of the soil and the structure with equal rigor. Adopting direct method of analysis, the numerical model can perform fully nonlinear time-history dynamic analysis to simulate realistic dynamic behaviour of the soil and the structure under seismic excitations.

ABAQUS/CAE is divided into functional units called modules, where each module defines a logical aspect of the modelling process; for example, defining the geometry, defining material properties, and generating a mesh. As you move from module to module, you build the model from which ABAQUS/CAE generates an input file that you submit to the ABAQUS/Standard or ABAQUS/Explicit analysis product. The analysis product performs the analysis, sends information to ABAQUS/CAE to allow you to monitor the progress of the job, and generates an output database.

6.2. CONSTITUTIVE Material Model

In order to obtain accurate analysis, proper material models are needed. To be able to understand the mechanical behavior to final failure, it is important that this non-linear behavior can be simulated in the finite element analyses. The nonlinearities of the concrete in compression and the steel were accounted for with plasticity models. Three major effects cause the non-linear response of reinforced concrete namely:

- Crushing of concrete in compression.
- Cracking of concrete in tension.
- Yielding of reinforcement.

Nonlinearities also arise from the interaction of the constituents of reinforced concrete such as, bond - slip between reinforcing steel and surrounding concrete, aggregate interlock at a crack and dowel action of the reinforcing steel crossing a crack. The steel elements were provided with isotropic multi linear elastic-plastic material model.

6.2.1. Concrete

Concrete Damaged of the possible the constitutive compressive pressure sensitive The material model compressive and compressive formation of

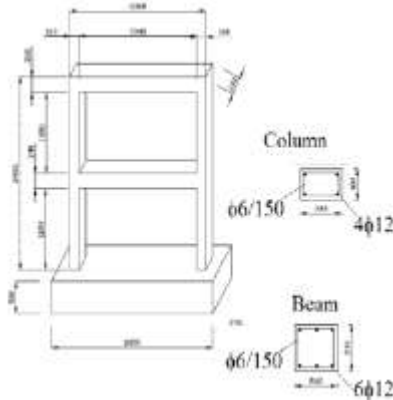

response. The post-failure behaviour for direct straining is modelled using tension stiffening, which also allows for the effects of the reinforcement interaction with concrete. Thus, this material model reflects the key characteristics of concrete well. The reinforcement was modelled separately using rebar elements with metal plasticity models. In this study, only longitudinal reinforcement was included.

Damaged Plasticity

ABAQUS (Hibbitt, Karlsson and Sorensen, 2001) supplies the Plasticity (CDP) model for monotonic, cyclic and dynamic loading. CDP is one constitutive models to predict the constitutive behavior of concrete. It describes behavior of concrete by introducing scalar damage variables. Tensile and response of concrete can be characterized by CDP. The yield criterion is and based on the work by Lubliner et al. (1989) and Lee and Fenves (1998). uses isotropic damaged elasticity in association with isotropic tensile and plasticity, to represent the inelastic behaviour of concrete. Both tensile cracking crushing are included in this model. Beyond the failure stress in tension, the micro-cracks is represented macroscopically with a softening stress-strain

6.2.2. Mesh Size

In finite element analysis (FEA), the accuracy of the FEA results and required computing time are determined by the finite element size (mesh density). According to FEA theory, the FE models with fine mesh (small element size) yields highly accurate results but may take longer computing time. On the other hand, those FE models with coarse mesh (large element size) may lead to less accurate results but smaller computing time. Also, small element size will increase the FE model's complexity which is only used when high accuracy is required. Large element size, however, will reduce the FE model's size and is extensively used in simplified models in order to provide a quick and rough estimation of designs. Due to its importance, in generating FEA models, the foremost problem is to choose appropriate elements size so that the created models will yield accurate FEA results while save as much computing time as possible. The aim of this section is to establish a simple three-dimensional nonlinear model for RC model. The model employed element C3D20, which is a nonlinear 20-node solid element for concrete and steel rebar's.

The elements were connected together with appropriate constraints to represent the interaction between various components of the model assembly. In this respect, to simulate the bond between concrete and reinforcement, the reinforcement was embedded in the concrete using the "Embedded Constraint" option in ABAQUS, which enforces full compatibility was used which assumes full bond.

Element size has significant effect on accuracy of finite element results. It affects the convergence of the problem, computational time and penetration between the master and slave surfaces. Fine mesh could improve the accuracy of results; but, it increases the computational time required to do the simulation. Two types of mesh elements were used; linear and quadratic, results show that using quadratic meshing made the error smaller due to Small size of FE leads to the smaller error with less computational time.

VII. VERIFICATION MODELS

In this respect, two experimental output data for reinforced concrete(RC) frames using pushover analysis and an additional experimental output data based on nonlinear time history analysis (three records for each) were compared with the output results from ABAQUS 6.14 software analytical models in order to check the reliability and validity of a nonlinear finite element model.

7.1. Experimental Data

Model-1:

S. Z. Korkmaz et al. 2010 [13] Tested one bay, two-story bare reinforced concrete(RC) specimen with no infill wall under a reversed cyclic loading. The goal of this test was to report on an experimental study about the Turkish EQ Code on proposed strengthening method. The specimens were subjected to lateral load that simulate the seismic action at the story level. Cycles were named as forward and backward cycles. Also, axial load was applied to top of columns. The test setup, instrumentation and loading system is presented in Fig. 14. Dimensions and details of test specimens are presented in Fig. 15. Fig. 16 shows the ABAQUS analysis model conducted for this model. While Fig. 17 shows plastic hinges formation & crushing in concrete.

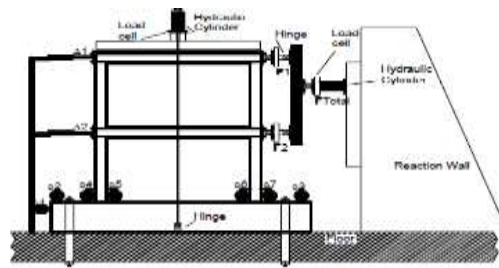

Fig. 14. Test setup, loading system and instrumentation

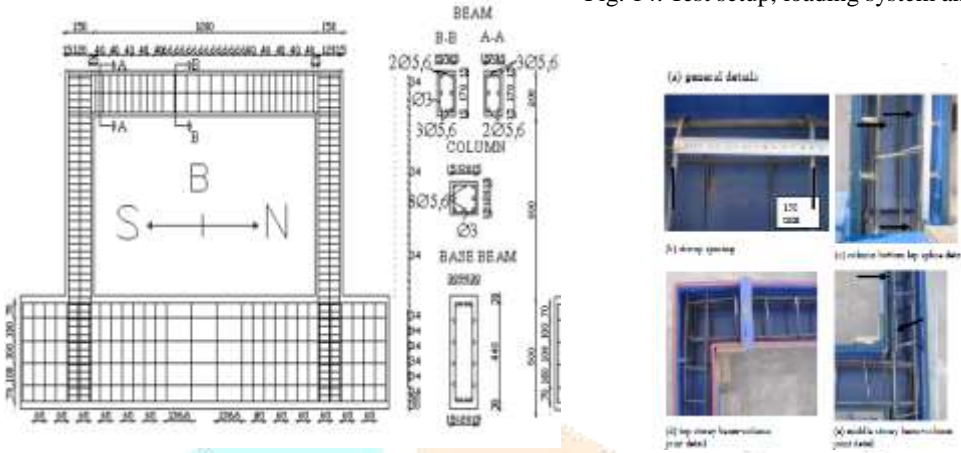

Fig. 15. Dimensions and details of test specimens

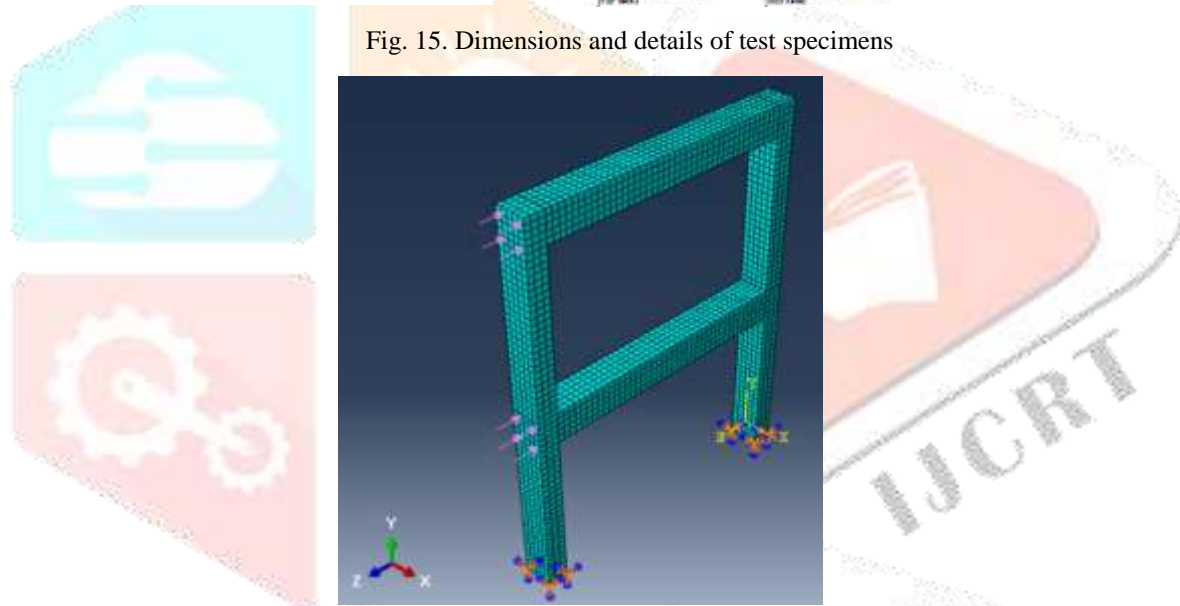

Fig. 16. ABAQUS analysis model conducted for model-1

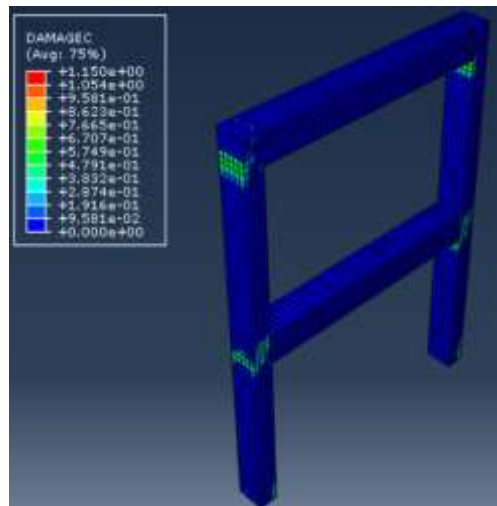

Fig. 17. Plastic hinges formation & crushing in model-1

Model-2:

Ch. G. Karayanniset al.2005 [14]. Tested single bay single story bare reinforced concrete(RC) frame specimen was constructed and tested under lateral loading. The test aims to study behavior of bare and masonry in-filled reinforced concrete(RC) frames under lateral cyclic loading, Reinforcement detailing of the reinforced concrete(RC) frame model is presented in Fig. 18. Test setup is shown in Fig. 18. Propagation of cracks was recorded for bare frame as presented in Fig. 19. Fig. 20 shows the ABAQUS analysis model conducted for this model. While Fig. 21 shows plastic hinges formation & crushing in concrete.

Fig. 18. Reinforcement detailing of the reinforced concrete (RC) frame model (mm)

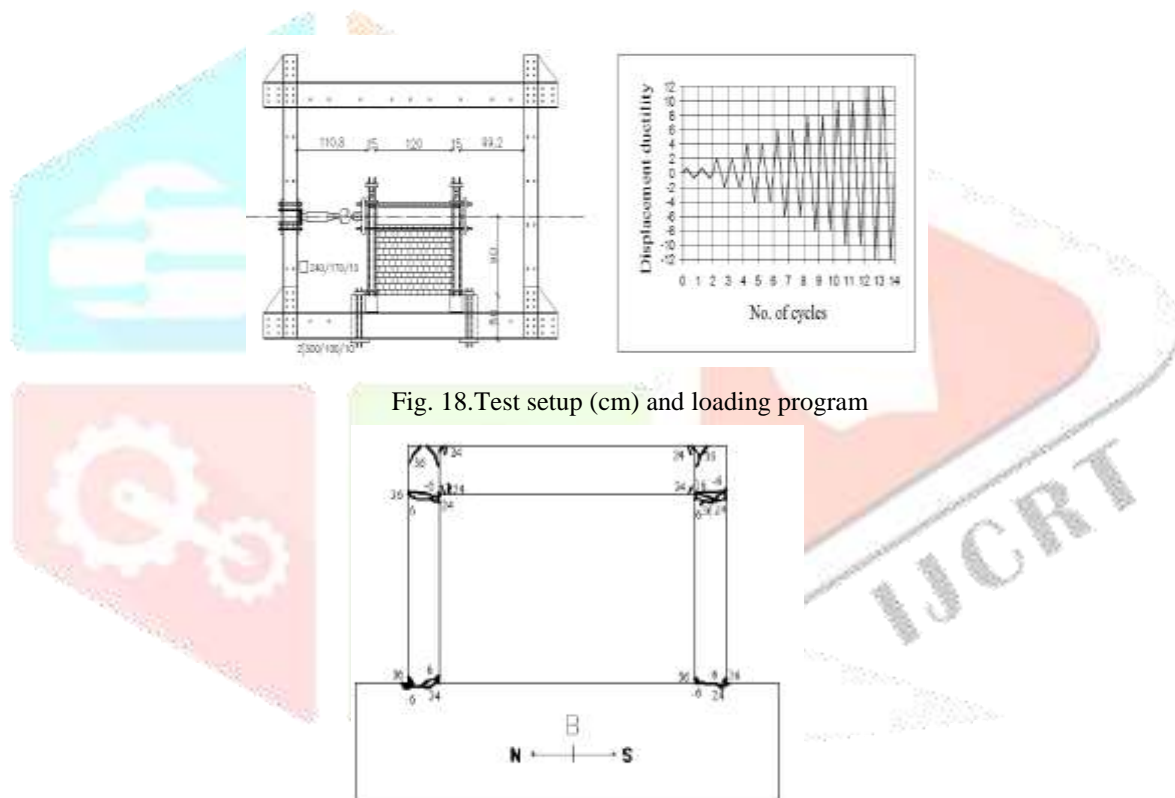

Fig. 18. Test setup (cm) and loading program

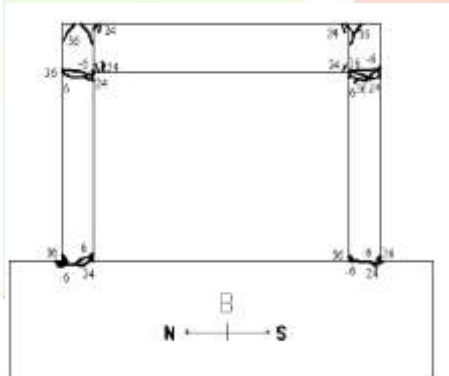

Fig. 19. Propagation of cracks for bare frame

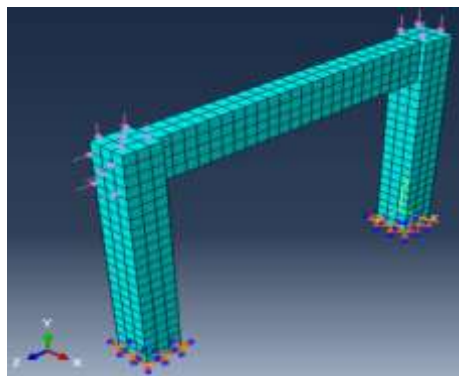

Fig. 20. ABAQUS analysis model conducted for model-2

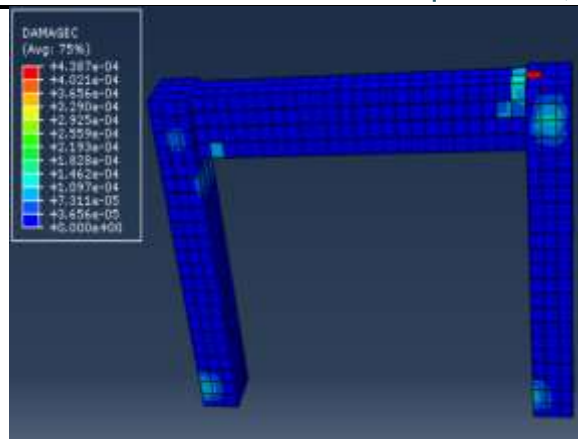

Fig. 21. Plastic hinges formation & crushing in model-2

Model-3:

For the numerical nonlinear time history analysis investigation, three records for each were compared by AslanSadeghiHokmabadi et, al.(2014) [16]. Fig. 22 illustrate the shaking table tests were performed by applying scaled earthquake acceleration records of 1994 Northridge, 1995 Kobe, and 1940 El Centro to the fixed-base structural models. Fig. 23 shows the ABAQUS analysis model using time history analysis.

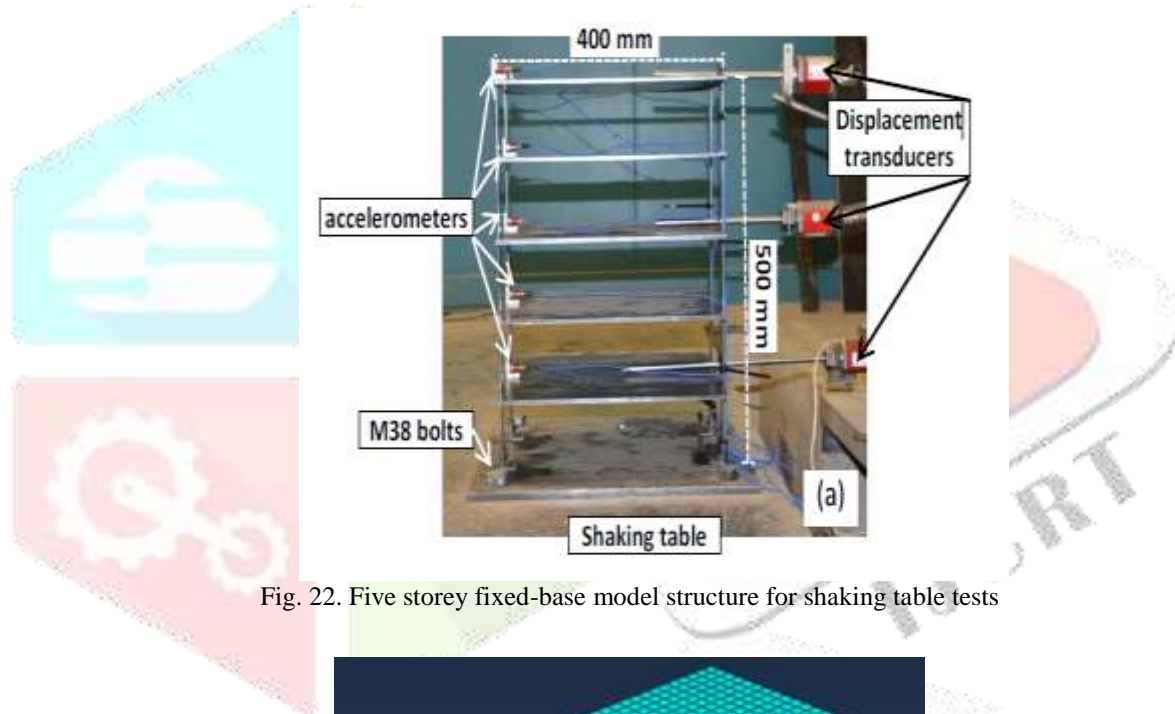

Fig. 22. Five storey fixed-base model structure for shaking table tests

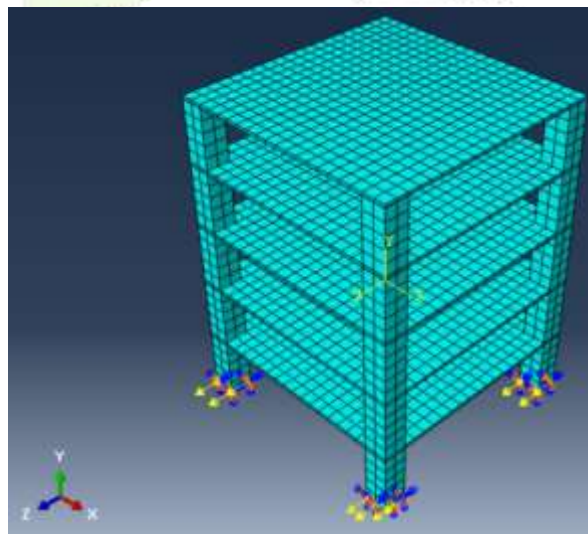

Fig. 23. ABAQUS analysis model for Fivestorey fixed-base structure

7.1. Verification of Experimental Results

A comparison between experimental and analytical load-displacement curves for all reinforced concrete frames is presented in Figs. 24. The Fig. shows that the analytical load-displacement curves are matching the experimental load-displacement curves. The quadratic

curve also refers to the analytical results but using quadratic meshing instead of linear meshing, considering that using quadratic meshing in the analysis increases the accuracy of results. As shown in Fig. 24, using quadratic meshing make the error smaller.

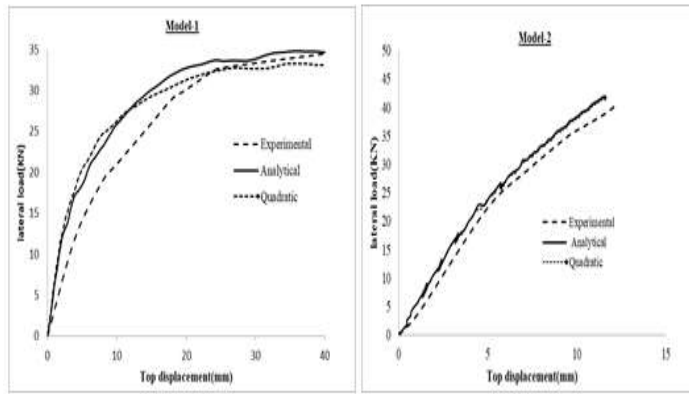

Fig. 24. Modeling Results for reinforced concrete (RC) frames specimens

Model	Experimental (shear)	Analytical (shear)	% Error	Experimental (displacement)	Analytical (displacement)	% Error
	Q_{ult} (KN)	Q_{ult} (KN)		Δ_{ult} (mm)	Δ_{ult} (mm)	
1	34.51	34.77	0.75%	40	31.50	21.25
2	40.50	41.85	3.33%	12.21	11.50	5.82

Table 1 shows the comparison between experimental and analytical values of ultimate flexural strength.

While for model-3, time history results were verified as shown in Table 2 & Fig. 25.

Table 1 Results for models-1 & 2 (Pushover analysis)

Story No.	(NORTHRIDGE 1994)		(KOBE 1995)		(ELCENTRO 1940)	
	Experimental	Analytical	Experimental	Analytical	Experimental	Analytical
0	0	0	0	0	0	0
1	1.3	1.55	1.2	1.473	1.5	1.32
3	6.8	6.14	7.2	6.43	6.5	5.67
5	11	10.6	10.5	9.64	8	6.51

% Error (NORTHRIDGE 1994)	
Story No.	Displacement
0	0
1	19.2
3	9.7
5	3.1

% Error (KOBE 1995)	
Story No.	Displacement
0	0
1	22.75
3	10.69
5	8.19

% Error (ELCENTRO 1940)	
Story No.	Displacement
0	0
1	12.00
3	12.77
5	18.63

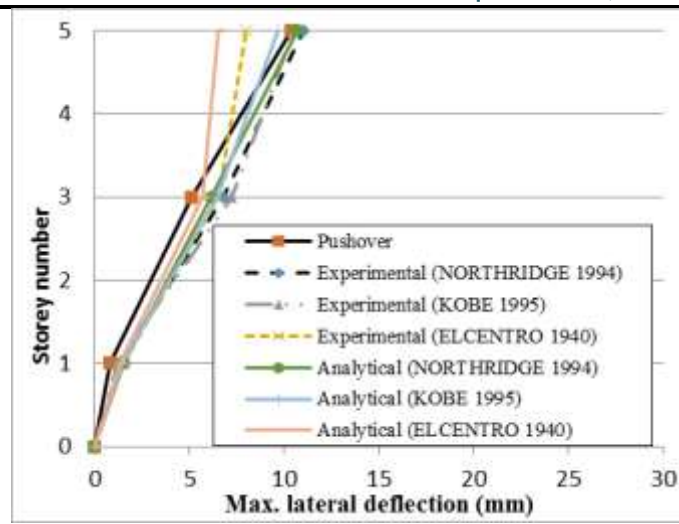

Fig. 25. Results for Time history Analysis Records

Table 2 Results for model-3 (Time history analysis)

Live Loads	
Sample model	
Pulling Force	300+24(Lo-7) kN
Braking Force	250+20(Lo-7) kN
Lateral Shock Effect	100 kN (in horizontal direction perpendicular to railway direction)

VIII. PARAMETRIC STUDY

In this study, RC elevated metro stations with different configurations were utilized to estimate the response reduction/modification factor(R) using time history and static push-over analysis. Estimation of R value in this study depends significantly on how well the non-linear behavior of this RC system is presented in analysis.

RC elevated metro stations were designed according to ECP code for design 2017 [17] & ECP code for loading 2012 [18] and material properties are taken as following:

- Concrete compressive strength (cube) (fcu) =40 MPa
- Steel yield strength (fy) = 400 MPa for vertical reinforcement and stirrups.
- Steel young’s modulus (Es) =200 GPa
- Specific weight for wall =18 kN\m3
- Dimension of concrete column (2000x2000) mm with height equal to 8m.
- Dimension of beam girder (2000x2500) mm.
- Height of platform level and mechanical level =2.80m
- Spacing between columns equal to 14m, total length of metro station equal to 42 m with height 21.9m.
- All RC sections were designed using ETABS software.

RC elevated metro station loads are considered according to ECP code of loads as follow:

- Considered loads for platform and under platform level, FC= 4 kN/m² and LL= 6 kN/m².
- Considered loads for box girder supporting the train according to ECP code in the following table:

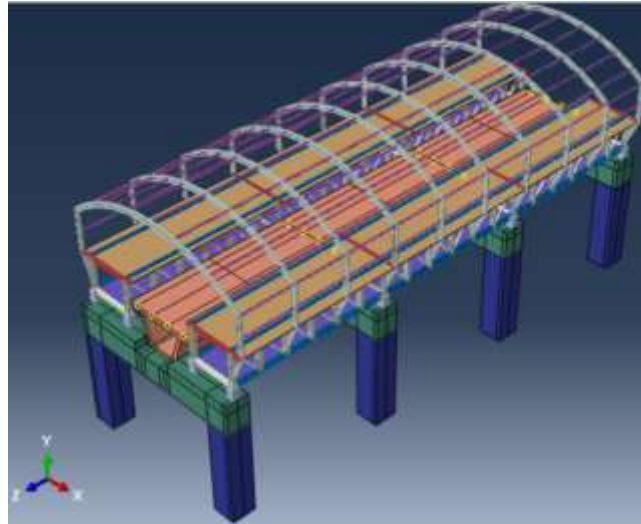
**Configuration for RC elevated metro stations was analyzed as follows:**

- RC metro station with Double cantilever beam system supported on one column with 2 platform levels, considering under platform & platform levels & mechanical level with steel cladding, as shown in Fig. 26-a and reinforcement details are shown in Fig. 27-a.
- RC metro station with a frame system with 2 platform levels, considering under platform & platform levels & mechanical level with steel cladding, as shown in Fig. 26-b and it's details in Fig. 27-b.

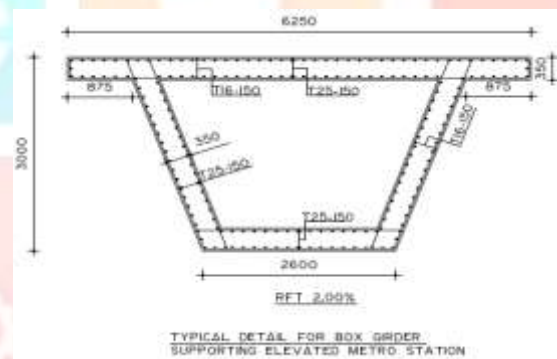

Fig. 26-a: Elevated RC metro station system for case study-1

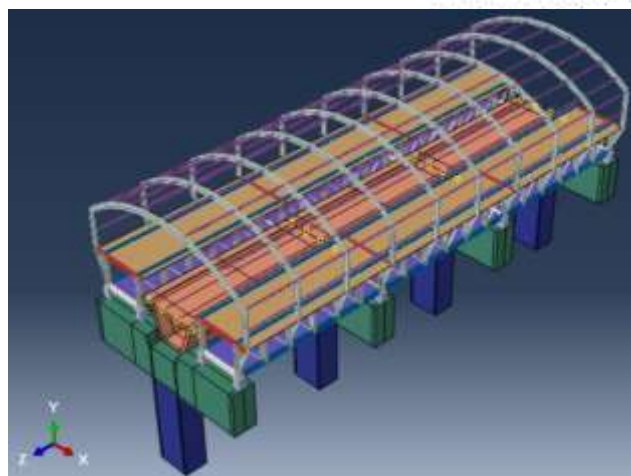

Fig. 26-b. Elevated RC metro station system for case study-2

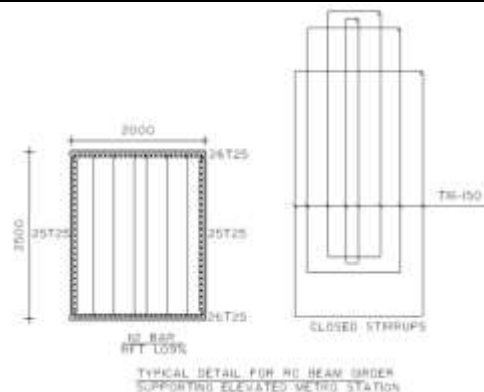

Fig. 27-a: Elevated RC metro station details for cantilever system

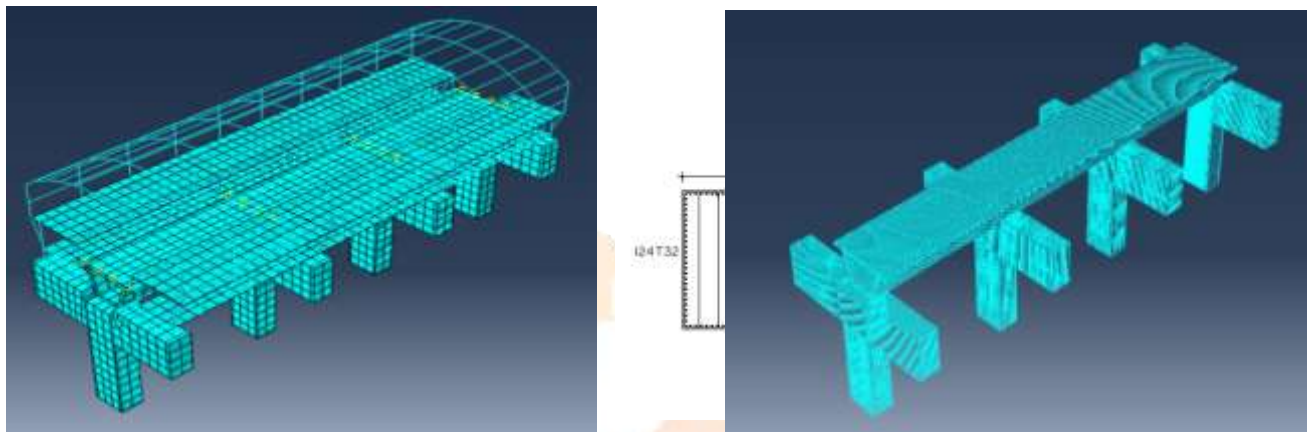

Fig. 27-b: Elevated RC metro station details for framing action system

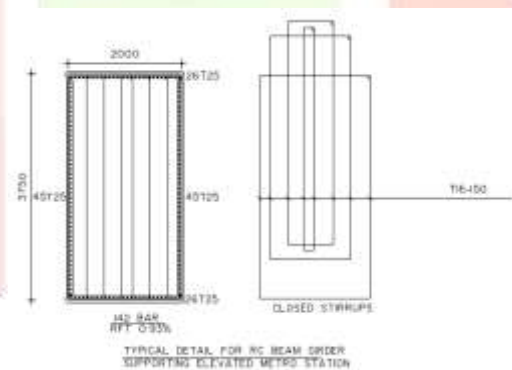

Fig. 28 shows the ABAQUS modeling for concrete solid elements and steel wire elements, while Fig. 29 shows the boundary conditions for the concrete footing had locked translational degrees of freedom in all directions.

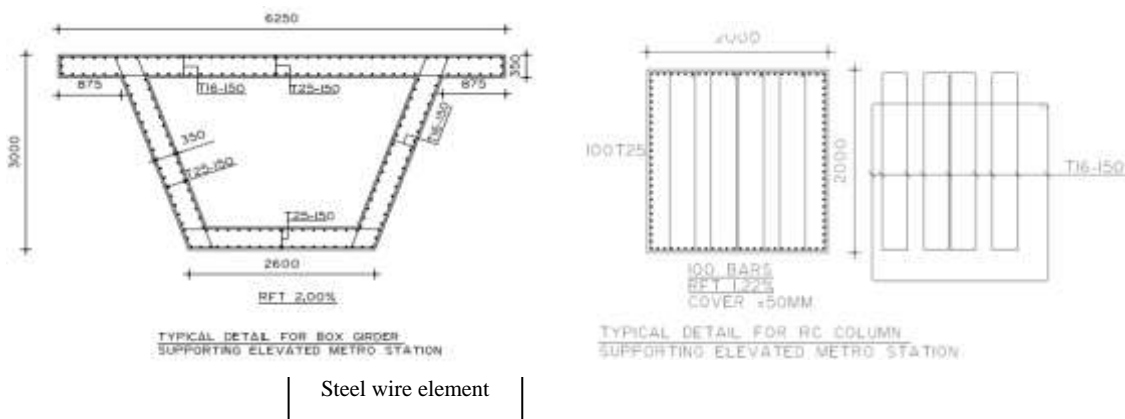

Fig. 28-a: Element mesh for case study-1

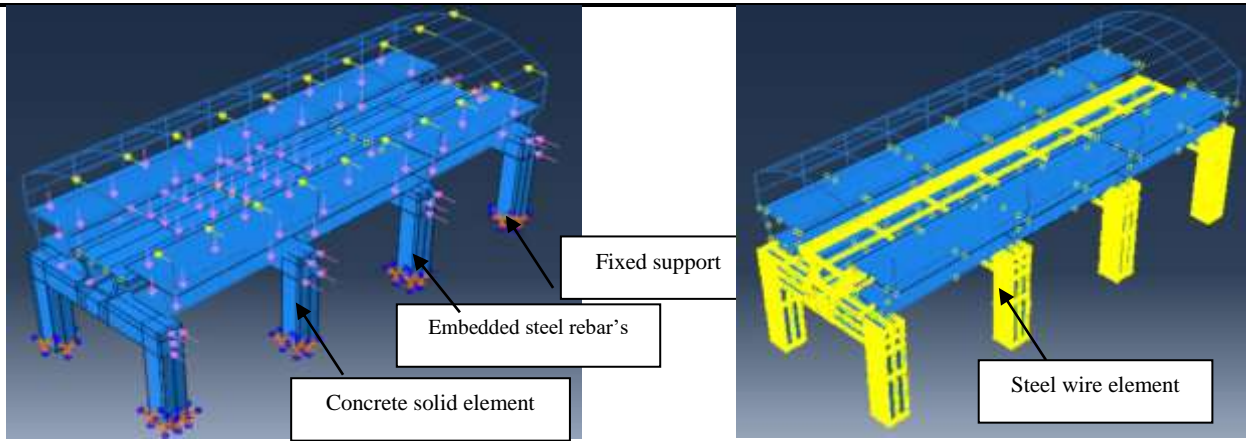

Fig. 28-b: Element mesh for case study-2

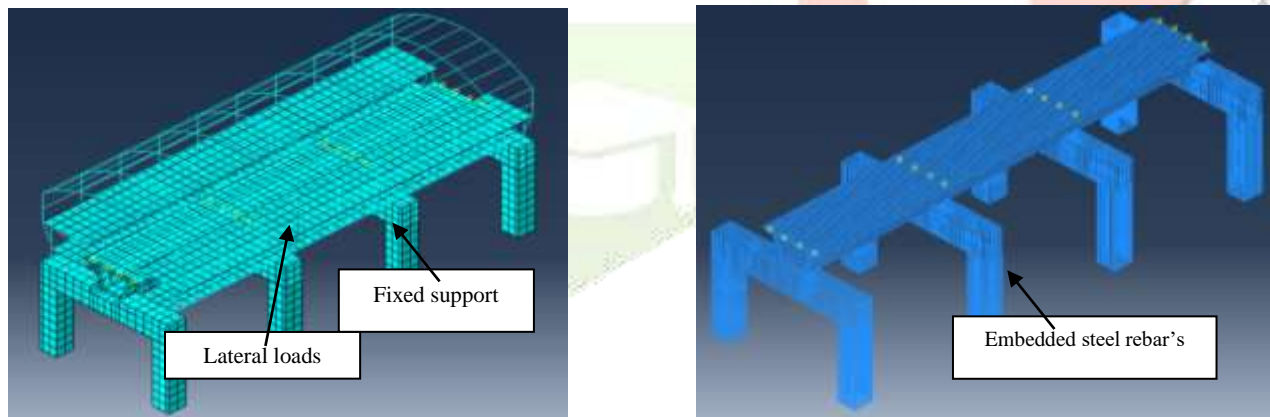
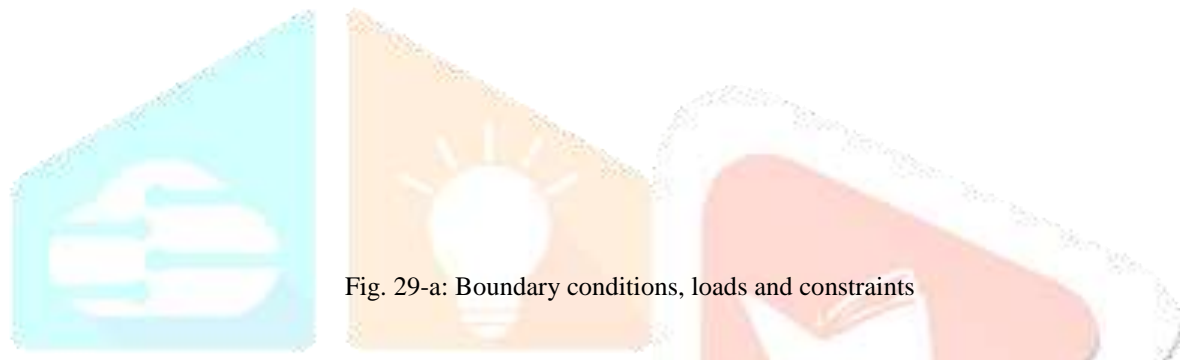
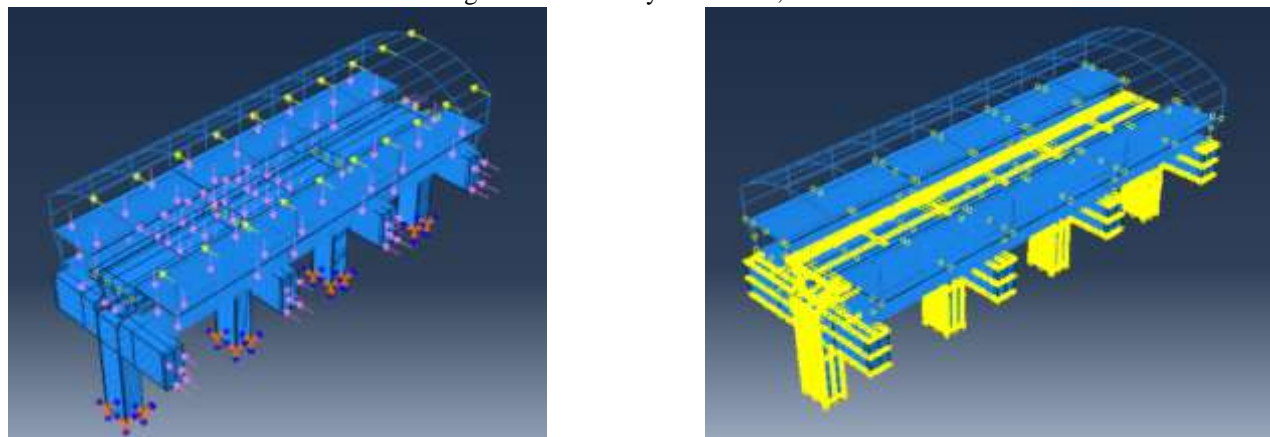

Fig. 29-b: Boundary conditions, loads and constraints



IX. FAILURE CRITERIA

The analyses were continued until the stress in reinforcement reached 400MPa as shown in Fig. 31 or the strain in concrete reached 0.003 (according to ECP code [17]) as shown in Fig. 32.

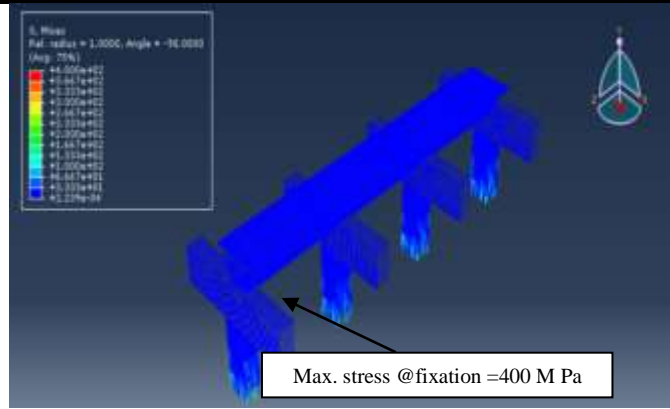

Fig. 31-a: Yield stress for reinforcement = 400MPa

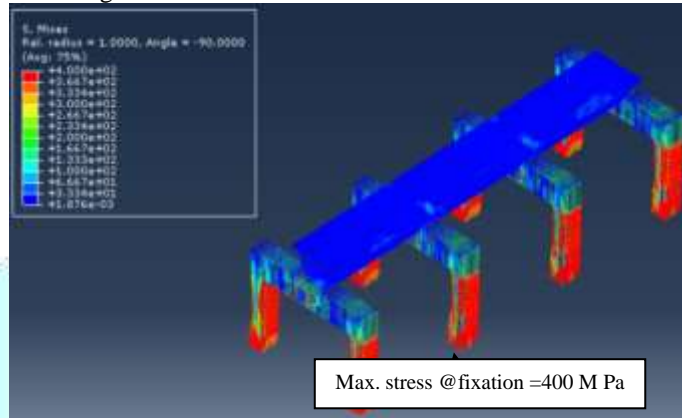

Fig. 31-b: Yield stress for reinforcement = 400MPa

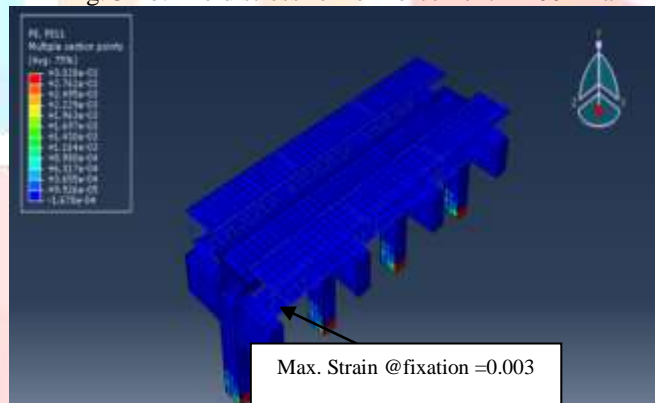

Fig. 32-a: Strain for concrete = 0.003

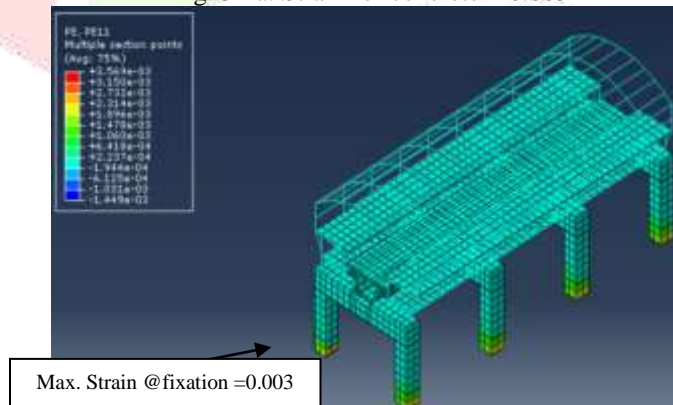

Fig. 32-b: Strain for concrete = 0.003

X. OBSERVATIONS FROM THE PARAMETRIC STUDY

10.1. Pushover Results

The results of RC elevated metro stations with two different configurations are listed in Table 3 and Fig. 33.

Table 3 Results for RC (2 stories elevated metro stations) based on pushover analysis

Case of study	V_u (KN)	V_d (KN)	T second	T second	R_s	Δ_u (mm)	Δ_u (mm)	μ	R_μ	R
Cantilever system	2392.5	1435.5	0.91	0.52	1.67	14.10	6.8	2.07	2.07	3.47
Frame system	4590.3	2392.54	0.91	0.48	1.67	9.00	4.25	2.00	1.81	3.02

- ^a V_d Design base shear equal 60% of the ultimate load capacity as suggested by Uang (1991) [10]
- ^bT Calculated time period based on ECP requirements, time period don't exceed:

$$(1.2 * 0.075 * h^{0.75}) \quad (5)$$
- ^cT Fundamental period obtained from ETABS model for multi degree of freedom.
- ^d $R_s = V_u / V_d$
- ^e Δ_u Max Top displacement at V_u , calculated based on peak load, as recommended by Park, R., and Paulay, T, 1988 [18].
- ^f Δ_y yield displacement, calculated based on equivalent elasto plastic energy absorption, as recommended by Park, R., and Paulay, T, 1988 [18].
- ^g μ = Ratio between the ultimate displacement and the yield displacement (Δ_u / Δ_y).
- ^h R_μ Function of μ depends on time period:

$$T < 0.2 \text{ seconds } , R_\mu = 1$$

$$0.2 < T < 0.5 \text{ seconds } , R_\mu = (2\mu - 1)^{0.5}$$

$$T > 0.5 \text{ seconds } , R_\mu = \mu$$

(1): R calculated based on time period as suggested by Newmark and Hall (1982) [11] in equations (2).

Fig. 33-a: Normalized lateral load versus normalized top displacement for cantilever system

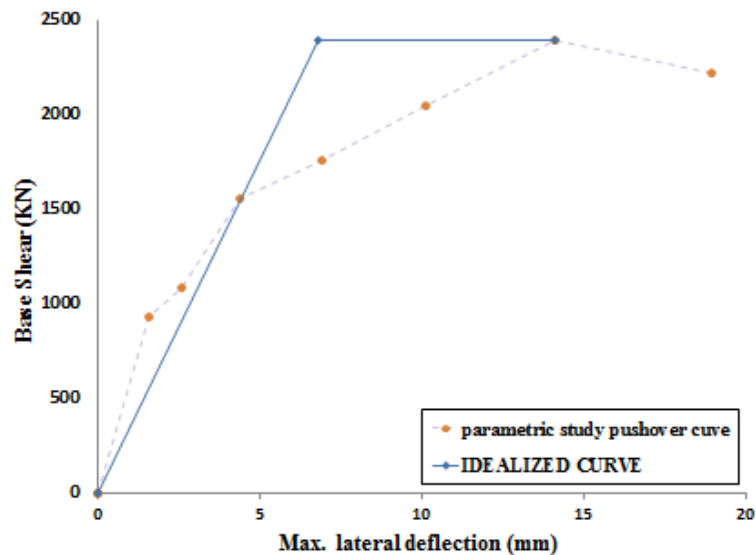
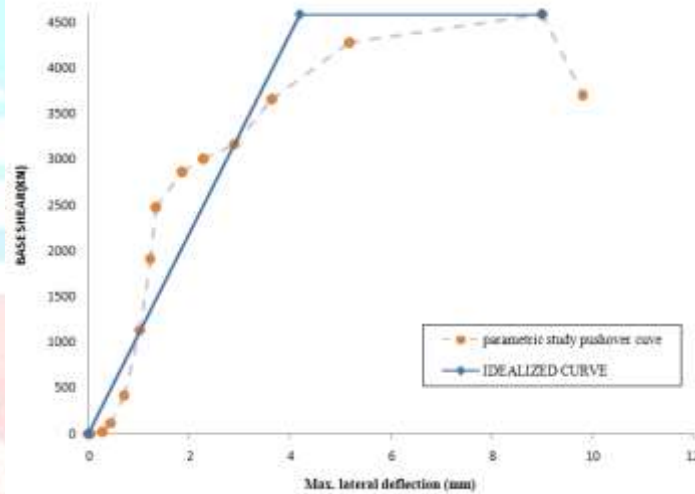

Fig. 33-b: Normalized lateral load versus normalized top displacement for frame system



10.2. Time History Results

Each frame model is subjected to selected records with incremental increase (scaling) of the PGA until a performance limit state is reached. The overall procedure to quantify the seismic force reduction factor (R) is based on the approach presented by Uang (1991) [10]. The properties of the three selected ground motions were listed in Table 4. The R values as shown in Table 5 are assumed as the ratio between elastic lateral load (V_e), which would develop in the seismic force resisting system if the system remained entirely elastic under the design earthquake ground motions, and design lateral force (V_d). A comparison between time history results and pushover results are listed in Table 6.

Table 4 Properties of ground motions (adopted from PEER 2006)

Record	Earthquake	Site	Date	PGA (g)	PGA (MAX) (g)
1	San Fernando	La Hollywood Stor Lot	Feb- 09, 1994	0.174	1.55
2	San Francisco	Golden Gate	March- 22, 1944	0.112	2.90
3	Northridge	Playa Del Rey	Jan- 17, 1994	0.136	1.03
4	Imperial Valley	Bonds Corner	Oct- 15, 1979	0.775	1.13
5	Imperial Valley	El-Centro	May- 19, 1940	0.143	1.29
6	Imperial Valley	El-Centro	May- 19, 1940	0.313	1.19
7	Loma Prieta	Apeel Crystal-Spr Res	Oct- 18, 1989	0.104	1.33

Table 5 Results for all reinforced concrete (RC) frames models based on time history analysis

Record	V _d =1417.5 KN (For cantilever system)		V _d =2392.54 KN (For frame system)	
	V _e (KN)	R= V _e / V _d	V _e (KN)	R= V _e / V _d
1- San Fernando(1994)	7205	5.03	10970	4.59
2- San Francisco(1944)	5668	3.95	8308	3.47
3- Northridge(1994)	6498	4.53	10208	4.27
4- Imperial Valley(1979)	5300	3.7	7769.5	3.25
5- Imperial Valley(1979)	6756	4.7	10656	4.45
6- Imperial Valley(1940)	3805	2.65	5582.6	2.33
7- Loma Prieta(1989)	6164	4.3	9340	3.90
	AVG.	3.9	AVG.	3.75

Table 6 Comparison between time history results and pushover results for case study-1

Cases of study	Pushover (R) ^a	Pushover (R) ^b	Time history (R)
1-cantliver system	3.47	3.47	3.9
2-frame system	3.02	3.58	3.75

(a): R calculated based on time period as suggested by Newmark and Hall (1973, 1982) [18] in equation (2).

(b): R calculated based on $R_{\mu}=\mu$.

IV. CONCLUSION

This paper is performed to investigate the variation of seismic response of RC structures of different configurations of special RC structures, such as elevated metro stations. Consequently, the response reduction factor can be evaluated. Then the calculated response reduction/modification factors (R) for reinforced concrete (RC) structures will be compared to those specified in ECP [17] and the ASCE code [19].

Some interesting conclusions could be extracted from the parametric study regarding the building behavior, considering that the (R) factor values calculated in this research are related to the studied special structure only, as follows:

- The response reduction/modification factor(R) value is almost the same as the mentioned value in ASCE codes. The structural system of the studied RC elevated metro station was considered to be ordinary moment frames according to ACI 318[20], section 21.2, as columns having a height less than five times the length of the rectangular columns in the moment direction.
- The response reduction/modification factor(R) value is almost the same as the mentioned value in EURO CODE 8 code [22] ($q=q_0K_DK_RK_W$), where ($q=5*0.75*0.8=3$).
- The response reduction/modification factor(R) value is almost the same as the mentioned value in UBC code[6], where ordinary structure=3.5).
- The (R) value doesn't match those values mentioned in ECP code due to lack of parameters affecting the R value, because the recommended values for (R) factor in the ECP code aren't affected by height of RC structures, which affect ductility factor.
- The response reduction /modification factor(R) value decreases while ductility factor decrease due to decreasing in time period.
- The (R) factor value for RC elevated metro station cantilever system is larger than that for the frame system because the frame system has a higher stiffness which leads to lower ductility and also lower time period.
- The base shear gives higher value for cantilever system than that for frame system because the stiffness of the frame is higher than that for the stiffness of the cantilever system.
- The response reduction /modification factor(R) value, calculated based on ($R_{\mu} = (2\mu-1)^{0.5}$), for frame system analysis model using pushover analysis is low compared to time history analysis because the ductility factor depends on the fundamental period which has a value lower than 0.5 second in pushover analysis.
- The R-values (based on $R_{\mu}=\mu$) from pushover analysis for cantilever system and frame system are approximately the same.
- The R-values (based on $R_{\mu}=\mu$) from pushover analysis are close to those calculated based on time history analysis.
- The time period calculated based on the structural analysis is less than the calculated time period based on ECP code ($1.2*0.075*h^{0.75}$), because ECP code considers the RC structures height only as an affecting parameter on time period. Lesser time period leads to decreasing in (R) factor.
- The response reduction/modification factor(R) value is sensitive to both RC statically system and RC geometry.

NOTATIONS

- CDP: Concrete Damaged Plasticity
- EQ : Earthquake
- Es: Steel young's modulus
- F_{cu} : Concrete Compressive Strength
- Fy: Yield stress
- PGA: Peak Ground Acceleration
- PGV:Peak Ground Velocity
- R_{μ} : Ductility Factor
- R_s : Over-Strength Factor
- RC: Reinforced Concrete
- Rft: Reinforcement
- V_e : Max elastic Base Shear
- V_d : Design Base Shear
- V_u : Maximum Base Shear
- μ : Ductility Capacity

REFERENCES

- [1] AdeelZafar, "Response Modification Factor of Reinforced Concrete Moment Resisting Frames in Developing Countries", Submitted in partial fulfilment of the requirements for the degree of Master of Science in Civil Engineering in the Graduate College of the University of Illinois at Urbana-Champaign, 2009.
- [2] Bholebhavi, Inamdar, "AN Evaluation of Response Reduction Factors for irregular structures Using Linear Static Analysis", Issue 5 May 2016. DOI:10.15680/IJRSET.2016.0505136.
- [3] Tia Toby, Ajesh K. Kottuppillil," Evaluation of Response Reduction Factor using Nonlinear Analysis", IJRST: International Journal for Innovative Research in Science & Technology. ISSN (online): 2349-6010, DOI: 10.15680, Issue 06 | November 2015.
- [4] Hakim et al."Seismic Assessment of an RC building using pushover analysis", Saudi Arabia, 2014. DOI:10.5281/zenodo.14043
- [5] (SBC-301) Saudi Building Code.
- [6] UBC (Universal Building Code) 1997. DOI https://doi.org/10.1007/978-1-4615-0481-8_23.
- [7] Asgarian and Shokrgozar et al. "BRBF response modification factor", Journal of Constructional Steel Research, 2008.
- [8] Applied Technology Council (ATC), Structural response modification factors. Report ATC-19. Redwood City, CA (1995).
- [9] Applied Technology Council (ATC). Guidelines for seismic performance Assessment of Buildings (75% Draft): Volume1-Methodology, ATC58-1, Redwood City, CA, 2011.
- [10] Uang, C., "Establishing R (or R_w) and Cd factors for building seismic provisions", J. Struct. Eng., 117(1). 19-28(1991). DOI: 10.1061/(ASCE)0733-9445(1991)117:1(19)
- [11] Newmark, N. M., and Hall, W. J., "Earthquake spectra and design", EERI Monograph Series, Earthquake Engineering Research Institute, Oakland, Calif, 1982. DOI: 10.1007/s11803-016-0341-1.
- [12] ABAQUS software V6.14.
- [13] S. Z. Korkmaz, "Experimental study on the behavior of non-ductile infilled RC frames strengthened with external mesh reinforcement and plaster composite, Issue 18 November 2010. <https://doi.org/10.5194/nhess-10-2305-2010>
- [14] BehzadFatabiet, , Effect of Dynamic soil-pile-structure interaction on seismic response of mid-rise moment resisting frames", Issue June 2012.
- [15] AslanSadeghiHokmabadi, "Effect of Dynamic soil-pile-structure interaction on seismic response of mid-rise moment resisting framrs",Issue June 2014.
- [16] ECP (Egyptian Code of Practice for design), 2017.
- [17] ECP (Egyptian Code of Practice for Loading),2012.
- [18] Park, R., and Paulay, T "Reinforced Concrete Structures",Wiley,New York, 1988. DOI: 10.1002/9780470172834.ch5.
- [19] ASCE 7 (Minimum Design Loads for Buildings and Other Structures. American Society of Civil Engineers. USA), 2005. [https://doi.org/10.1061/\(ASCE\)0733-9445\(2005\)131:3\(507\)](https://doi.org/10.1061/(ASCE)0733-9445(2005)131:3(507)).
- [20] ACI318m (2014).
- [21] PEER database (PEER 2006).
- [22] Eurocode 8 Provisions (2004).