

A DESIGN OF SRF BASE DYNAMIC VOLTAGE RESTORER WITH BATTERY ENERGY STORAGE SYSTEM

Dr.P.Vasedeva Naidu, Ph.D¹. R.V.Ravivarma ²

Assistant Professors¹, M.Tech student²,Department of EEE,GITAM University

Abstract: This paper deals with, design of SRF based Dynamic voltage restorer with battery energy storage system. The DVR consist of voltage source converter coupled with energy storage system .In this paper a new controlled technique is proposed to control the capacitor supported DVR. The reference injected voltage are estimated or (generated using synchronous reference frame theory) Hence the SRF based DVR compensated all voltage related power quality issues the detail analytical study and evaluation by the proposed topology with DVR systems and validated through simulation results

Index Terms—Dynamic voltage restorer (DVR), power quality, voltage sag, voltage swell, SRF based

1.Introduction:

In recent years, there has been an increased emphasis and concern for the quality of power delivered to factories, commercial establishments, and residences. This is due to the increasing usage of harmonic-creating nonlinear loads such as adjustable-speed drives, switched mode power supplies, arc furnaces, electronic fluorescent lamp ballasts etc. [1-6]. Power quality loosely defined, as the study of powering and grounding electronic systems so as to maintain the integrity of the power supplied to the system. IEEE Standard 1159 defines power quality as : The concept of powering and grounding sensitive equipment in a manner that is suitable for the operation of that equipment. In the IEEE 100 Authoritative Dictionary of IEEE Standard Terms, Power quality is defined as: The concept of powering and grounding electronic equipment in a manner that is suitable to the operation of that equipment and compatible with the premise wiring system and other connected equipment. Good power quality, however, is not easy to define because what is good power quality to a refrigerator motor may not be good enough for today's personal computers and other sensitive loads. Power quality problems in the distribution systems are interruption, voltage sag and voltage swell due to the increased use of sensitive and critical equipments in the system. Some examples are equipments of communication system, process industries, precise manufacturing processes etc. Power quality problems such as transients, sags, swells and other distortions to the sinusoidal waveform of the supply voltage affect the performance of these equipments. The technologies like custom power devices are emerged to provide protection against power quality problems. Custom power devices are mainly of three categories such as series-connected compensator like dynamic voltage restorer (DVR), shunt connected compensator such as distribution static compensator (DSTATCOM), and a combination of series and shunt connected compensators known as unified power quality conditioner (UPQC) [7-10]. The series connected compensator can regulate the load voltage from the power quality problems such as sag, swell etc. in the supply voltage. Hence it can protect the critical consumer loads from tripping and consequent loss of production. The custom power devices are developed and installed at the consumer point to meet the power quality standards such as IEEE-519.

A DVR is used to compensate the supply voltage disturbances such as sag and swell. The DVR is connected between the supply and sensitive loads, so that it can inject a voltage of required magnitude and frequency in the distribution feeder. The DVR is operated such that the load voltage magnitude is regulated to a constant magnitude, while the average real power absorbed/supplied by it is zero in the steady state. The capacitor supported DVR is widely addressed in the literature. The instantaneous reactive power theory (IRPT) , sliding mode controller , instantaneous symmetrical components etc., are discussed in the literature for the control of DVR [11-15]. In this project a new control algorithm is proposed based on the current mode control for the control of DVR. The extensive simulation is performed to demonstrate its capability, using the MATLAB with its Simulink and Power System Block set (PSB) toolboxes.

2.1.DYNAMIC VOLTAGE RESTORER:

Among the power quality problems (sags, swells, harmonics...) voltage sags are the most severe disturbances. In order to overcome these problems, the concept of custom power devices is introduced recently. One of those devices is the Dynamic Voltage Restorer (DVR), which is the most efficient and effective modern custom power device used in power distribution networks. DVR is a recently proposed series connected solid state device that injects voltage into the system in order to regulate the load side voltage. It is normally installed in a distribution system between the supply and the critical load feeder at the point of common coupling (PCC). Other than voltage sags and swells compensation, DVR can also added other features like: line voltage harmonics compensation, reduction of transients in voltage and fault current limitations.

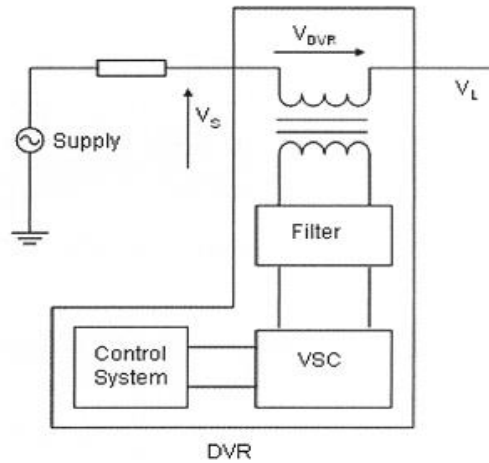

Fig.1.Schematic Diagram of DVR

Injection/ Booster Transformer:

The Injection / Booster transformer is a specially designed transformer that attempts to limit the coupling of noise and transient energy from the primary side to the secondary side. Its main tasks are:

1. It connects the DVR to the distribution network via the HV-windings and transforms and couples the injected compensating voltages generated by the voltage source converters to the incoming supply voltage.
2. In addition, the Injection / Booster transformer serves the purpose of isolating the load from the system (VSC and control mechanism).

2.3. Harmonic Filter:

The main task of harmonic filter is to keep the harmonic voltage content generated by the VSC to the permissible level.

2.4.Voltage Source Converter:

A VSC is a power electronic system consists of a storage device and switching devices, which can generate a sinusoidal voltage at any required frequency, magnitude, and phase angle. In the DVR application, the VSC is used to temporarily replace the supply voltage or to generate the part of the supply voltage which is missing. There are four main types of switching devices:

- a) Metal Oxide Semiconductor Field Effect Transistors (MOSFET)
- b) Gate Turn-Off thyristors (GTO)
- c) Insulated Gate Bipolar Transistors (IGBT), and
- d) Integrated Gate Commutated Thyristors (IGCT).

Each type has its own benefits and drawbacks. The IGCT is a recent compact device with enhanced performance and reliability that allows building VSC with very large power ratings. Because of the highly sophisticated converter design with IGCTs, the DVR can compensate dips which are beyond the capability of the past DVRs using conventional devices.

The purpose of storage devices is to supply the necessary energy to the VSC via a dc link for the generation of injected voltages. The different kinds of energy storage devices are Superconductive magnetic energy storage (SMES), batteries and capacitance.

2.5. DC Charging Circuit:

The dc charging circuit has two main tasks.

- a) The first task is to charge the energy source after a sag compensation event.
- b) The second task is to maintain dc link voltage at the nominal dc link voltage.

2.6.Control and Protection:

The control technique to be adopted depends on the type of load as some loads are sensitive to only magnitude change whereas some other loads are sensitive to both magnitude and phase angle shift. Control techniques that utilize real and reactive power compensation are generally classified as pre-sag compensation, in-phase compensation and energy optimization technique. For our study, pre-sag compensation was used where the load voltage is restored to its pre-sag magnitude and phase. Therefore, this method is suitable for loads which

are sensitive to magnitude and also phase angle shift. Differential current protection of the transformer, or short circuit current on the customer load side are only two examples of many protection functions possibility.

3.EQUATIONS RELATED TO DVR:

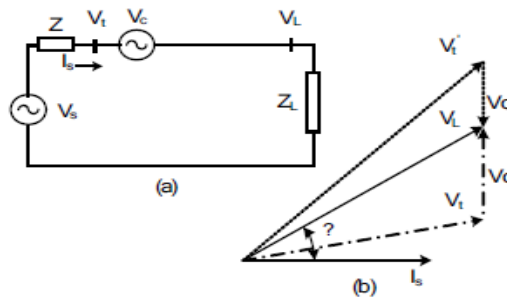

Fig.2 Equivalent Circuit diagram of DVR

The system impedance Z_{th} depends on the fault level of the load bus. When the system voltage (V_{th}) drops, the DVR injects a series voltage V_{DVR} through the injection transformer so that the desired load voltage magnitude V_L can be maintained. The series injected voltage of the DVR can be written as

$$V_{DVR} = V_L + Z_{th}I_L - V_{th} \tag{1}$$

Where

V_{DVR} : The desired load voltage magnitude

Z_{th} : The load impedance.

I_L : The load current.

V_{th} : The system voltage during fault condition.

The load current I_L is given by,

$$I_L = \left[\left(\frac{P_L + jQ_L}{V_L} \right) \right]^* \tag{2}$$

When V_L is considered as a reference equation can be rewritten as,

$$V_{DVR} \angle \alpha = V_L \angle 0 + Z_{th} I_L \angle (\beta - \theta) - V_{th} \angle \delta \tag{3}$$

α, β, δ are angles of V_{DVR}, Z_{th}, V_{th} respectively and θ is Load power angle

$$\theta = \tan^{-1}(Q_L/P_L) \tag{4}$$

The complex power injection of the DVR can

$$S_{DVR} = V_{DVR} I_L^* \text{ be written as, } \tag{5}$$

It requires the injection of only reactive power and the DVR itself is capable of generating the reactive power.

4.CONTROL SCHEME

The block diagram of the control scheme to generate the reference values of the compensator currents is shown in Fig. 3. The

desired source currents (in d-q components) are obtained as

$$i_{Sd}^* = \overline{i_{Ld}} + i_{Cd}$$

,

$$i_{Sq}^* = K_q \overline{i_{Lq}} + ui_{Cq} \tag{7}$$

where $\overline{i_{Ld}}$ and $\overline{i_{Lq}}$ are the average values of the d- and q- axis components of the load current, i_{Cd} is

the output of the DC voltage controller and i_{Cq} is the output of the AC voltage controller (if the bus voltage (V_t) is to be

regulated). u is a logical variable equal to (a) zero if PF is to be regulated and (b) one if bus voltage is to be regulated. $K_q = 1$ in the

latter case. When PF is to be controlled, K_q is determined by the required power factor as follows.

$$K_q = \frac{Q_S^*}{Q_L} \tag{8}$$

Where Q_S^* is the reference reactive power supplied by the source (at PCC) and Q_L is the average reactive power (at fundamental frequency) defined by

$$Q_L = |V_t| \overline{i_{Lq}} \tag{9}$$

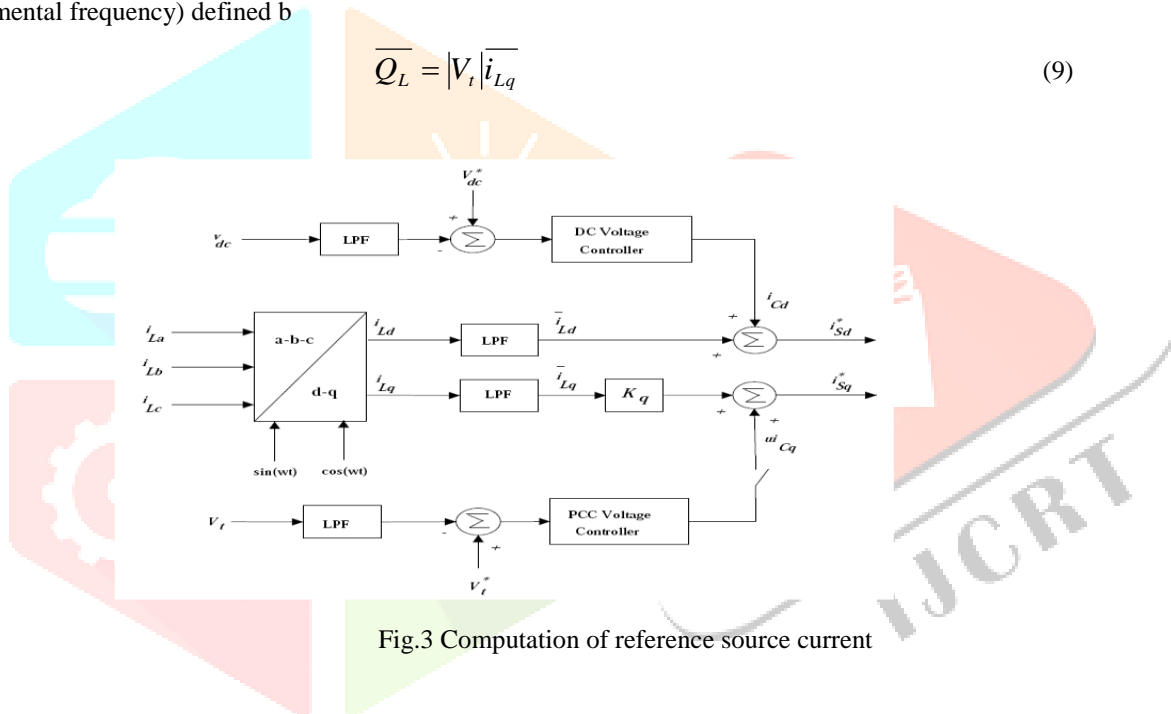

Fig.3 Computation of reference source current

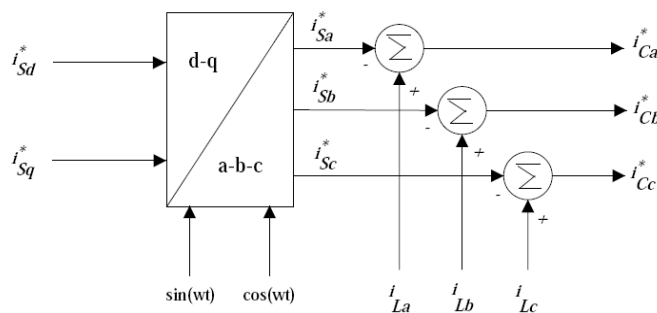

Fig.4 Generation of reference compensator currents

For unity power factor, $Q_S^* = 0$ and $K_q = 0$. The average values of $\overline{i_{Ld}}$ and $\overline{i_{Lq}}$ are obtained as the outputs of two identical low pass filters and are defined as

$$\begin{bmatrix} \overline{i_{Ld}} \\ \overline{i_{Lq}} \end{bmatrix} = G(S) \begin{bmatrix} i_{Ld} \\ i_{Lq} \end{bmatrix} \tag{10}$$

where $G(s)$ is chosen as the transfer function of a 2nd order Butterworth low pass filter (with a corner frequency of 30 Hz). The $d-q$ components are computed from the following relations

$$\begin{bmatrix} i_{Ld} \\ i_{Lq} \end{bmatrix} = \begin{bmatrix} \cos \omega t & -\sin \omega t \\ \sin \omega t & \cos \omega t \end{bmatrix} \begin{bmatrix} i_{L\alpha} \\ i_{L\beta} \end{bmatrix} \tag{11}$$

Where the $\alpha - \beta$ components are obtained

The reference vector of source currents is given by

$$\begin{bmatrix} i_{L\alpha} \\ i_{L\beta} \end{bmatrix} = \sqrt{\frac{2}{3}} \begin{bmatrix} 1 & -\frac{1}{2} & -\frac{1}{2} \\ 0 & -\frac{\sqrt{3}}{2} & \frac{\sqrt{3}}{2} \end{bmatrix} \begin{bmatrix} i_{La} \\ i_{Lb} \\ i_{Lc} \end{bmatrix} \quad \begin{bmatrix} i_{Sa}^* \\ i_{Sb}^* \\ i_{Sc}^* \end{bmatrix} = \sqrt{\frac{2}{3}} \begin{bmatrix} 1 & 0 \\ -\frac{1}{2} & -\frac{\sqrt{3}}{2} \\ -\frac{1}{2} & \frac{\sqrt{3}}{2} \end{bmatrix} \begin{bmatrix} i_{S\alpha}^* \\ i_{S\beta}^* \end{bmatrix} \tag{12}, (13)$$

where the $\alpha - \beta$ currents are given by

$$\begin{bmatrix} i_{S\alpha}^* \\ i_{S\beta}^* \end{bmatrix} = \begin{bmatrix} \cos \omega t & \sin \omega t \\ -\sin \omega t & \cos \omega t \end{bmatrix} \begin{bmatrix} i_{Sd}^* \\ i_{Sq}^* \end{bmatrix} \tag{14}$$

Note that ωt is the supply frequency expressed in radians/sec. The unit vectors $\sin \omega t$ and $\cos \omega t$ are obtained from Phase-Locked Loop (PLL) which is locked to the PCC voltage.

5.Simulink model of DVR

The DVR is modeled and simulated using the MATLAB and its Simulink and Power System Block set (PSB) toolboxes. The MATLAB model of the DVR connected system is shown in Fig.5 The three-phase source is connected to the three-phase load through series impedance and the DVR. The considered load is a lagging power factor load. The VSC of the DVR is connected to the system using an injection transformer.

Table.1

AC phase voltage	230V rms(Ph-Ph),60HZ
Un-balanced load	<i>phase-a</i> , $R = 150\Omega, L = 100mH$ <i>phase-b</i> , $R = 75\Omega, L = 100mH$ <i>phase-c</i> , $R = 50\Omega, L = 100mH$
Ripple filter values	$C_f = 1\mu F, R_f = 0.00002\Omega, L_f = 20mH$
PWM switching frequency	10KHZ
Series transformer	Three-phase transformer of rating 10000KVA,200V/200 V.
PLL gain	1/330

System

Parameters

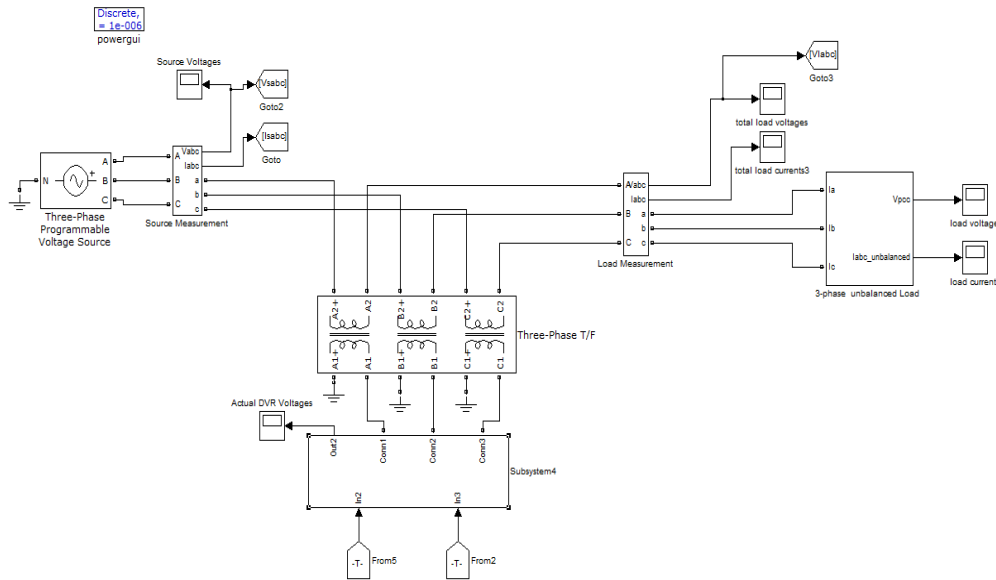

Fig. 5 MATLAB-based model of the Capacitor-supported DVR-connected system.

In addition, a ripple filter for filtering the switching ripple in the terminal voltage is connected across the terminals of the secondary of the transformer. The dc bus capacitor of DVR is selected based on the transient energy requirement and the dc bus voltage is selected based on the injection voltage level. The dc capacitor decides the ripple content in the dc voltage. The system data are given in Appendix.

The proposed control algorithm is modeled in MATLAB as shown in Fig.6. The reference supply currents are derived from the sensed load voltages, supply currents and dc bus voltage of DVR. The output of the PI controller used for the control of dc bus voltage of DVR is added with the direct axis component of current. Similarly, the output of the PI controller used for the control of the amplitude of the load voltage is added with the quadrature axis component.

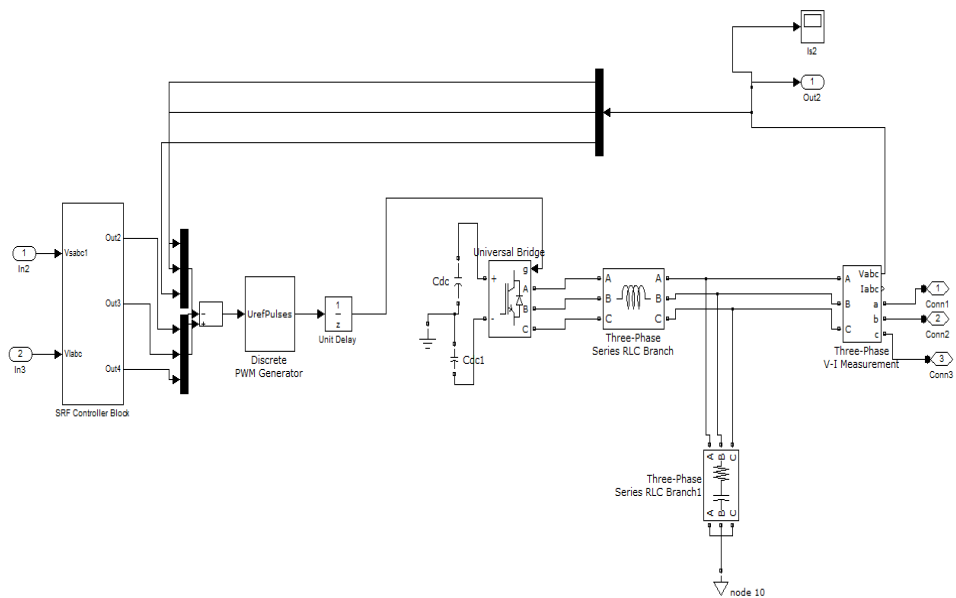

Fig. 6 Control block of DVR that uses SRF method of control.

A pulse width modulation (PWM) controller is used over the error between reference supply currents and sensed supply currents to generate gating signals for the IGBT’s (insulated gate bipolar transistors) of the VSC of DVR.

5.1.Voltage Sag

The proposed control scheme of DVR is verified through simulation using MATLAB software along with its Simulink and Power System Block set (PSB) toolboxes. The DVR injects fundamental voltage (V_c) in series with the terminal

voltages (V_{La}, V_{Lb}, V_{Lc}). The load voltage is maintained at the rated value. The terminal voltage (V_t), supply current (i_s), amplitude of terminal voltage (V_t) the amplitude of load voltage (V_L) and the dc bus voltage (V_{dc}) of DVR are also shown. It is observed that the dc bus voltage of DVR is maintained at reference value.

The performance of DVR is clarified for various supply voltage disturbances, for example, voltage sag and swell. Fig. 7 and Fig.10 describes the transient performance of the system underneath sag and swell conditions. A swell in supply voltage is observed at 0.03-0.05 seconds with an excess magnitude of 80v and sag in the supply voltage is observed at 0.02-0.04 seconds with a decreased magnitude of 80V. The load voltages are plotted in Fig. 9 and Fig.12 for both swell and sag conditions, which exhibits the in-phase Voltage injection by DVR. The load voltage is kept up sinusoidal by injecting appropriate compensation voltage by the DVR

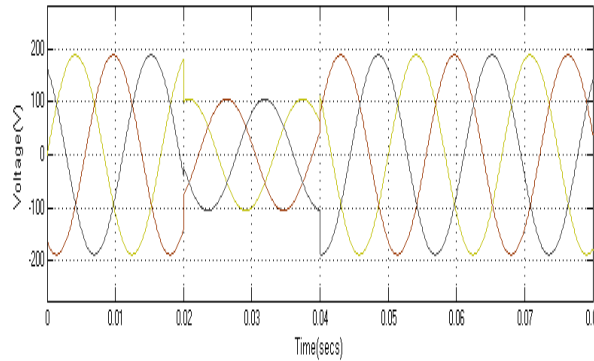

Fig.7 Performance of DVR during voltage sag.

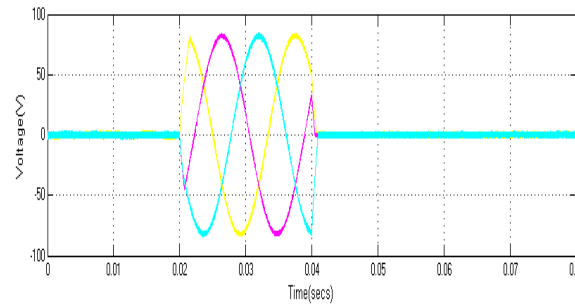

Fig.8 Voltage injected by the DVR during sag.

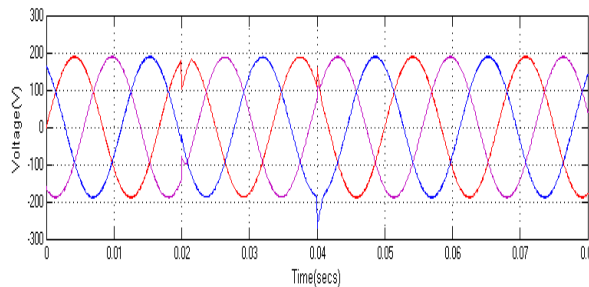

Fig .9.Load voltage

5.2.Voltage Swell

Similarly, in Fig.10, a swell in terminal voltage (V_t) has occurred at 0.03 sec up to 0.05 sec and the load voltage (V_L) is observed to be satisfactory due to the proper voltage injection by the DVR. The load voltage (V_L) is maintained at the rated value. The terminal voltage (V_t),supply current (i_s), the amplitude of terminal voltage (V_t), the amplitude of the load voltage (V_L) and the dc bus voltage (V_{dc}) of DVR are also shown. It is observed that the dc bus voltage of DVR is maintained at reference value, though perturbation is occurring during transients.

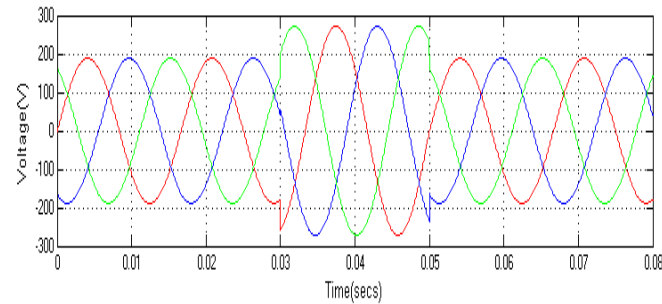

Fig .10Performance of DVR during Voltage swell

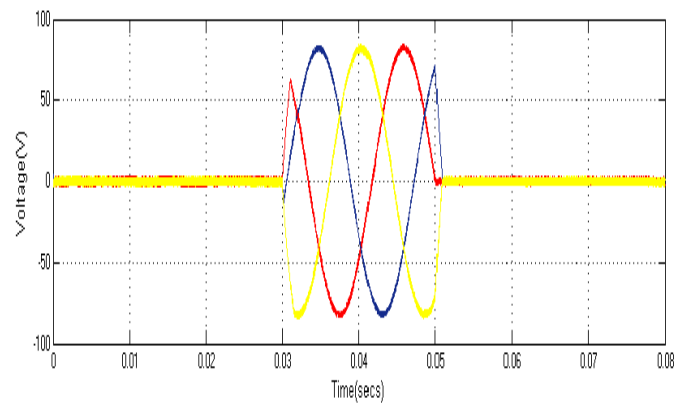

Fig.11 Voltage injected by the DVR during swell.

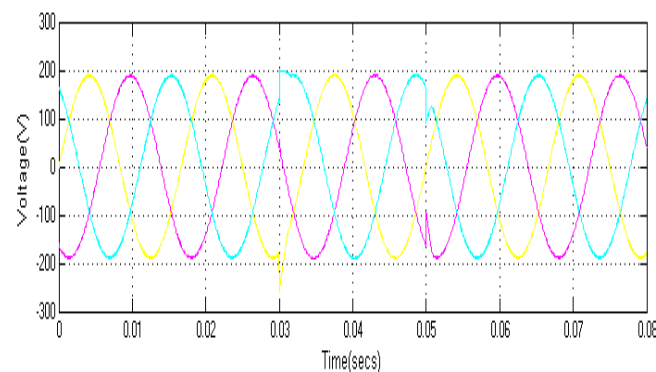

Fig.12 Load voltage.

6.CONCLUSION

The task of a DVR has been clarified with another control system utilizing different voltage injection plans. A mechanism is proposed to control the capacitor supported DVR. The mechanism of DVR is explained with a reduced rating VSC. Using the unit vectors, the reference load voltage is evaluated and the mechanism of DVR has been achieved, which limits the error of voltage injection. SRF theory is used to change the voltages from rotating vectors to the stationary frame. A correlation of the performance of the DVR with various plans has been performed with a reduced

References

- [1] H. Hingorani "Introducing custom power" IEEE spectrum, vol.32 no.6 June 1995 p 41-48.
- [2] M. Bollen, "What is power quality?" Electric Power Systems Research, vol. 66, no. 1, pp. 5–14, Jul. 2003.
- [3] T. S. Key, "Diagnosing power quality-related computer problems," IEEE transactions on Industry Applications, vol. IA-15, no. 4, pp. 381–393, Jul.1979.
- [4] M. H. J. Bollen, Understanding power quality problems: voltage sags and interruptions. Piscataway, NJ: IEEE Press, 2002.
- [5]M. H. J. Bollen, Understanding power quality problems: voltage sags and interruptions. Piscataway, NJ: IEEE Press, 2002

- [6] A. Ghosh and A. Joshi, "The concept and operating principles of a mini custom power park," IEEE Trans. Power Del., vol. 19, no. 4, pp.1766–1774, Oct. 2004.
- [7] W. Reid, "Power quality issues-standards and guidelines," IEEE Transactions on Industry Applications, vol. 32, no. 3, pp. 625–632, May–Jun. 1996.
- [8] O. Anaya-Lara and E. Acha, "Modeling and analysis of custom power systems by PSCAD/EMTDC," IEEE Trans. Power Del., vol. 17, no. 1, pp. 266–272, Jan. 2002.
- [9] Vasudeva Naidu Pudi, Basavaraja Banakara "A New Proposal for Voltage Regulation Multi Feeders/Multibus Systems Using MC-DVR" in fourth International Conference on Power and Energy Systems (ICPS-2011), IIT Madras 22-24 Dec 2011, pp.1-8.
- [10] Ray Arnold "Solutions to Power Quality Problems" power engineering Journal, Volume 15; Issue: 2 April 2001, pp: 65-73.
- [11] Benachaiba Chellali, FERDI Brahim, "Voltage Quality Improvement Using DVR", Electrical Power Quality and Utilizations, Journal Vol.XIV, No.1, 2008.
- [12] Vasudeva Naidu Pudi, Basavaraja Banakara "Design of a SRF Based MC UPQC Used for Load Voltage Control in Parallel Distribution Systems" in. in the 2012 IEEE Fifth PowerIndia Conference PICONF-2012, Deenbandhu Chhotu Ram University of Science & Technology, Murthal, India, 19-22 Dec-2012, pp.1-6.
- [13] Hague, M.H." Compensation of distribution system voltage sag by DVR and D-STATCOM", IEEE Porto Power Tech Conference, Volume: 1, 10th-13th Sept. 2001.
- [14] V. Khadkikar and A. Chandra, "A Novel Structure for Three-Phase Four-Wire Distribution System Utilizing Unified Power Quality Conditioner (UPQC)," *IEEE Transactions on Industry Applications*, vol. 45, no. 5, pp. 1897 –1902, Sep.- Oct. 2009.
- [15] P. Vasudeva Naidu and Dr. B. Basavaraja "PSO based optimization of PI regulator and VA loading of a SRF-based multi converter DVR" in International Journal of Engineering, Science and Technology (IJEST), ISSN: 2141-2839, Vol. 7, No.1, Jan 2015, pp: 44-58.M.

