

# INTELLIGENT IRRIGATION

R. Vinotha, Prof. Mrs. T.K. Swathi

Student, Electrical and Electronics, IFET College of Engineering, Villupuram, India

Professor, Electrical and Electronics, IFET College of Engineering, Villupuram, India

**Abstract:** In India, 75% of the current fresh water is consumed in the agricultural irrigation. Therefore, efficient water management plays an important role in the irrigated agricultural cropping systems. The main problem in conventional agriculture is water consumption of each crop. The only solution to this problem is smart agriculture by modernizing the current traditional methods. When making smart agriculture, by using IOT technologies the network problems will occur. To overcome these network problems the high frequency zigbee transmitter receiver is to be used for data transmission. And by adding regulator, the threshold value of the soil moisture sensor is varied for each crop. So we need not worry about the large water consuming plants in drip irrigation. And due to automation of drip irrigation manpower and water consumption is to be reduced.

**IndexTerms – Soil moisture sensor, Zigbee.**

## INTRODUCTION:

Horticulture is considered as the premise of life for the human species as it is the principle wellspring of sustenance grains and other crude materials. It assumes key part in the development of nation's economy. It additionally gives expansive plentiful business chances to the general population. Development in farming segment is vital for the improvement of monetary state of the nation. Sadly, numerous agriculturists still utilize the customary techniques for cultivating which brings about low yielding of harvests and natural products. In any case, wherever computerization had been executed and individuals had been supplanted via programmed apparatuses, the yield has been moved forward. Henceforth there is have to execute present day science and innovation in the agribusiness area for expanding the yield. The vast majority of the papers means the utilization of remote sensor arrange which gathers the information from various sorts of sensors and after that send it to primary server utilizing remote convention. The gathered information gives the data about various natural components which in swings screens the framework. Observing natural components isn't sufficient and finish answer for enhance the yield of the products.

### I. HARDWARE USED:

**1. PIC MICROCONTROLLER (PIC 16F877A):** The microcontroller used is, low power PIC 16F877A – 1/P , 2 PWM 10-bit microcontroller, having 256 Bytes In-system self-programmable EEPROM data memory, ICD, 25mA sink/source per I/O & Parallel Slave Port.

**2. ZIGBEE MODULE:** ZigBee is utilized for accomplishing remote correspondence amongst field and rancher's home. The range for Zigbee is about 50 meters and it can be expanded utilizing high power modules or by utilizing system of modules. It works on 2.4 GHz recurrence. Its energy utilization is low and it is more affordable when contrasted with different remote modules like Wi-Fi or Bluetooth. It is typically used to set up remote neighborhood.

**3. SOIL MOISTURE SENSOR:** Soil dampness sensor measures the water content in soil. It utilizes the property of the electrical protection of the dirt. The relationship among the deliberate property and soil dampness is adjusted and it might differ contingent upon natural factors, for example, temperature, soil compose, or electric conductivity. Here, It is utilized to detect the dampness in field and exchange it to microcontroller with a specific end goal to make controlling move of exchanging water pump ON/OFF. Fig.1 shows the structure of soil moisture sensor.

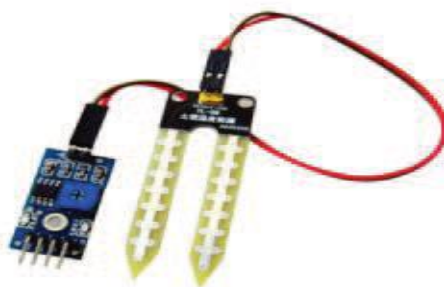

Fig 1: Soil moisture sensor

**4. TEMPERATURE SENSOR LM35:** The LM35 is exactness IC temperature sensor. Yield voltage of LM35 is straightforwardly corresponding to the Centigrade/Celsius of temperature. The LM35 does not require outer alignment or trimming to give precise temperature extend. It is minimal effort sensor. It has low yield impedance and straight yield. The working temperature run for LM35 is  $-55^{\circ}$  to  $+150^{\circ}\text{C}$ . With ascend in temperature, the yield voltage of the sensor increments

directly and the estimation of voltage is given to the microcontroller which is duplicated by the transformation factor keeping in mind the end goal to give the estimation of real temperature.

**5. HUMIDITY SENSOR:** The DHT11 is an essential, minimal effort computerized temperature and dampness sensor. It gives out advanced esteem and thus there is no compelling reason to utilize change calculation at ADC of the microcontroller and subsequently we can give its yield straightforwardly to information stick rather than ADC. It has a capacitive sensor for estimating dampness. The main genuine weakness of this sensor is that one can just get new information from it simply after like clockwork. Fig.2 shows the structure of humidity sensor.

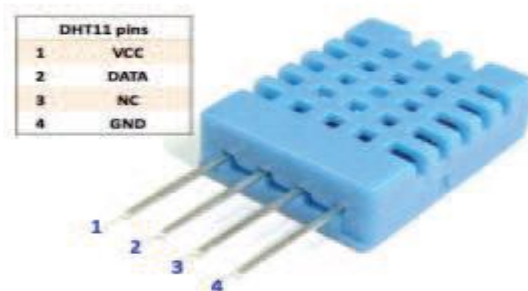

Fig 2: Humidity sensor

**6. OBSTACLE SENSOR:** The ultra-sonic sensor works on the guideline of sound waves and their appearance property. It has two sections; ultra-sonic transmitter and ultra-sonic beneficiary. Transmitter transmits the 40 KHz sound wave and recipient gets the reflected 40 KHz wave and on its gathering, it sends the electrical flag to the microcontroller. The speed of sound in air is as of now known. Consequently from time required to get back the transmitted sound wave, the separation of deterrent is figured. Here, it is utilized for impediment recognition if there should arise an occurrence of versatile robot and as a movement indicator in product house for counteracting robberies. The ultra-sonic sensor empowers the robot to identify and maintain a strategic distance from impediments and furthermore to quantify the separation from the obstruction. The scope of task of ultra-sonic sensor is 10 cm to 30 cm.

## II. SOFTWARE USED:

### PROTEUS 8 SIMULATOR:

Proteus 8 is one of the best simulation software for various circuit designs of microcontroller. It has almost all microcontrollers and electronic components readily available in it and hence it is widely used simulator. It can be used to test programs and embedded designs for electronics before actual hardware testing. The simulation of programming of microcontroller can also be done in Proteus. Simulation avoids the risk of damaging hardware due to wrong design.

## III. OPERATION AND WORKING:

### POWER SUPPLY:

The 5V PV panel is used to provide the supply. A 15V rechargeable battery is connected to it. Which stores the energy and will provide the supply when the sun light is gone.

### DATA ACQUISITION FROM SENSOR:

The sensor is interfaced with PIC microcontroller and programmed. Once it is programmed it is placed inside a box and kept in the field. The soil moisture sensor has two probes which is inserted into the soil. The probes are used to pass current through the soil. The moisture soil has less resistance and hence passes more current through the soil whereas the dry soils has high resistance and pass less current through the soil. The resistance value help detecting the soil moisture.

**DATA TRANSMISSION:** The data acquired from sensors are transmitted to the farmer's house(receiver) via zigbee. The transmitter and receiver modules are connected with PIC microcontroller. The transmitter is place in the field and the receiver is placed in the farmer's house.

### CONTROL MECHANISM:

The threshold values vary according to the crops planted. This is because different crops need different amounts of water. For example in a paddy field to produce 1 kg of rice 5000 liters of water and for wheat it is liters. The soil moisture will be different in summer and winter seasons. The temperature and humidity also varies in summer, winter and rainy season. The threshold values is fixed after considering all these environmental and climatic conditions. The motor will be switched on automatically if the soil moisture value falls below the threshold and vice versa.

And in this project the farmer can change the threshold value of the soil moisture sensor according to the type of crop. The motor should be off when the threshold value is to be reached. So the large amount of water consuming plants couldn't be affected.

### AUTOMATION OF IRRIGATION:

When the threshold value of the soil moisture sensor decreases the motor can ON automatically. If the threshold value is to be reached the motor can OFF automatically. And The threshold value of the soil moisture sensor is fixed by the farmer. The

receiver can receives the data. And the status of the motor and threshold value of the temperature sensor is to be displayed in a LCD display.

#### IV. BLOCK DIAGRAM:

The sensors are used to sense the moisture and temperature of the land. The threshold values from sensors are send to pic microcontroller. This controller gives the data to the zigbee transmitter. And at the receiver section the status of the motor , threshold value of soil moisture sensor and temperature are to be displayed. The regulator is connected to the transmitter for changing the threshold value of soil moisture sensor. Fig 3, 5 shows the block diagram of transmitter and receiver. Fig 2,4 shows the arrangement of transmitter and receiver.

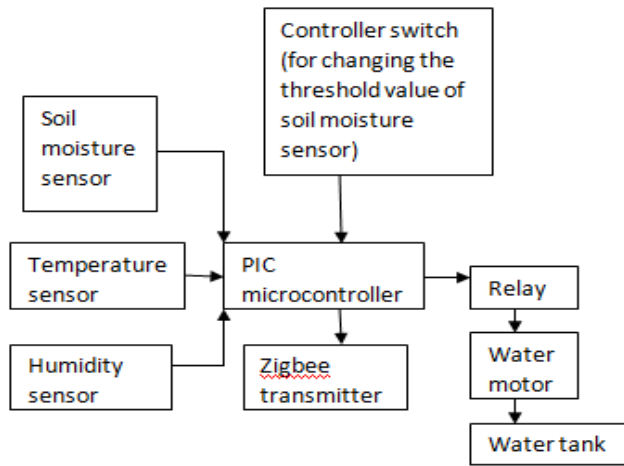

Fig 3: Block diagram of Transmitter

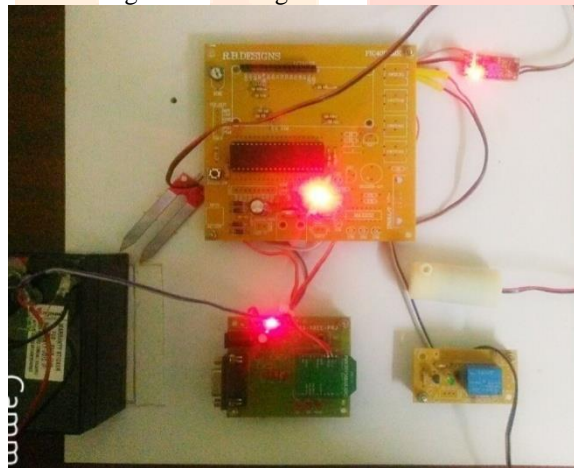

Fig 4 : Transmitter

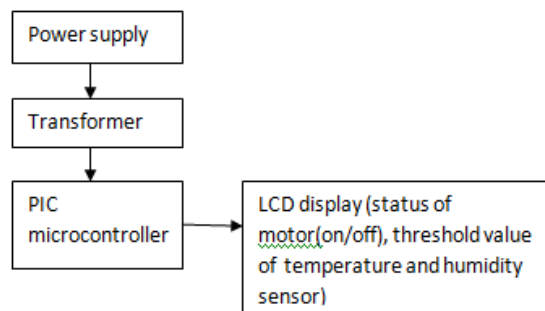

Fig 5: Block diagram of Receiver



Fig 6 : Receiver

### CIRCUIT DIAGRAM

The aim of the project is to control a motor based on the moisture in the soil. The design of the circuit is as follows. PIC 16F877A is the main processing IC. Fig 7 shows the Auto irrigation using soil moisture sensor and pic microcontroller.

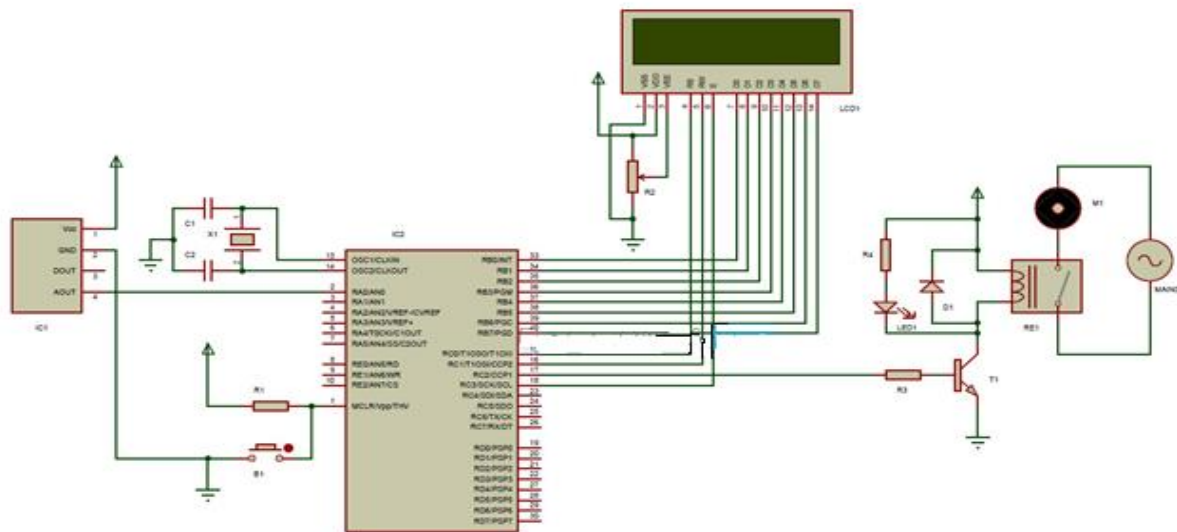

Fig 7: Auto-irrigation system using soil moisture sensor and pic microcontroller

A 12 MHz crystal oscillator is connected across OSC1 and OSC2 (Pins 13 and 14). The crystal is connected with two 33pF capacitors. The Master Clear pins is normally connected to Vcc via a pull-up resistor. A bypass button is connected to ground. This button is used to reset the microcontroller. The output of the soil moisture sensor is given to RA0 (Pin 2) of the PIC microcontroller. An LCD is used to display the key messages. The data pins of the LCD are connected to Port B of the PIC (Pins 33 – 40). The control pins of the LCD are connected to the Port C. The connections are as follows: RS pin of LCD to RC0 (Pin 15) of PIC, RW to RC1 (Pin 16) and E to RC3 (Pin 18). In order to drive the relay which is connected to the motor, a transistor is used. The input to the transistor is given from RC2 (Pin 17) of PIC microcontroller. One terminal of the relay coil is supplied with a 12 V DC. The other end of the coil is connected to the collector of the transistor. The contacts of the relay are given to the motor and AC supply. An LED is connected between the DC supply and the collector and glows only when the motor is running. Fig 8 shows the circuit diagram.

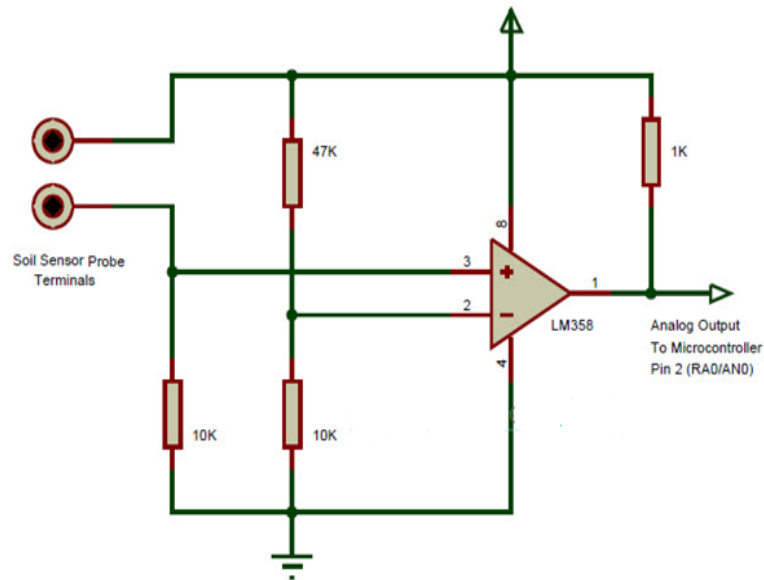

Fig 8: circuit diagram

## V. CONCLUSION:

The purpose of this system is to solve the problems faced in the traditional irrigation system. The main problem in smart irrigation is the water consumption of each crop is varied. Which can be satisfied by changing the threshold value of the soil moisture sensor for each crop. This threshold value is fixed by a farmer. Because who only knows about the what type of crop and what type of soil can consume what amount of water. So the threshold value of soil moisture sensor can be varied for each crop and soil. The motor is on when the moisture level is decreases than the threshold value of soil moisture sensor. So in this drip irrigation, need not worry about the large water consuming crops. And the number of towers in rural areas is less. So the network problems will occurs. To avoid these problems high quality zigbee transmitter receiver is to be used for data transmission process. And due to automation of motor the manpower is to be reduced. Water consumption is reduced.

## VI. REFERENCES:

- 1.Ashwini Raut,Mrunal Panse,Darshana Chaware, Aniruddha Koparkar“Sensor Based Automated Irrigation System”,International Journal of Engineering Research & Technology, ISSN: 2278-0181, Vol. 4 Issue 05, May-2015.
- 2.Sanjukumar, R.V.Krishnaiah, “Advance Technique for Soil Moisture Content Based Automatic Motor Pumping for Agriculture Land Purpose” International Journal of VLSI and Embedded Systems-IJVES, Vol 04, Article 09149 September 2013.
- 3.Meng Q, Ke G, Wang T, Chen W, Ye Q, Ma ZM, *et al.* A Communication- Efficient Parallel Algorithm for Decision Tree. 30<sup>th</sup> Conference on Neural Information Processing Systems (NIPS), Barcelona, Spain; 2016.
- 4.Kumar R, Singh MP, Kumar P, Singh JP. Crop Selection Method to Maximize Crop Yield Rate using Machine Learning Technique, 2015 International Conference on Smart Technologies and Management for Computing, Communication, Controls, Energy and Materials, Chennai, Tamil Nadu, India. 6-8 May 2015. p. 138-45.
- 5.Dr. V .Vidya Devi,G. Meena Kumari, “Real- Time Automation and Monitoring System for Modernized Agriculture” ,International Journal of Review and Research in Applied Sciences and Engineering (IJRRASE) Vol3 No.1. PP 7-12, 2013
6. S. R. Nandurkar, V. R. Thool, R. C. Thool, “Design and Development of Precision Agriculture System Using Wireless Sensor Network”, IEEE International Conference on Automation, Control, Energy and Systems (ACES), 2014