

# Auto Power Saving Unit for Huge System During Downtime Hours

Prof.Swati.D.Kale<sup>#1</sup>, Kailas Raut<sup>#2</sup>, Dipali Gobe<sup>#3</sup>, Jyoti Shukla<sup>#4</sup>

*Department of Electronics and Telecommunication,  
RajarshiShahu College of Engineering, Pune  
University  
Maharashtra, India.*

**Abstract**—Conservation of electricity has become a main part of economic growth and this conservation is more essential due to the concern for fast depletion of non-renewable sources of energy in the country. Many huge system like CNC conserve energy during a time, when there is no any type of operations like welding, drilling taking place on tool. This project is to save the power by using auto power saving unit utilized by the power consuming devices in huge system which are remain on during a down time hours. Where lots of power is wasted unnecessarily by keeping the hydraulic motors, conveyer belt, fans, lights ON even when there is no actual work is taking place .Moreover, as there is need to save the energy as much as possible so as to meet the future generation. This proposed model would be a great aid to the society. The purpose of this project is to save the power by using auto power saving unit utilized by the power consuming devices in huge system like CNC which are remain on during a down time hours.

**Keywords:** Relay, Timer, Microcontroller.

## I. INTRODUCTION

Nowadays there are many electronics appliances which are used in a CNC machine such as light, fan, conveyor, etc. In standby mode (on mode) the appliances consume some amount of energy for powering the turn-on fans, light, etc. Implementation of power source regeneration is another excellent means of reducing the power consumption of an electric motor system. During deceleration of an electric motor it will act as generator and energy is put back into the system. In a conventional system that energy is sent to a discharge resistor. A discharge resistor dumps that electrical energy in the form of heat. That waste heat is non-recoverable. By contrast power source regeneration returns electricity to the supply line to be used by other equipment. The electrical energy is recovered and waste heat is greatly reduced. Power source regeneration requires a drive system with an intelligent power module that can sense the flow of current and switch accordingly. When used the effects are significant. Implementing a servo driven system utilizing drive amplifiers with power source regeneration can see savings of 30% to 40% in electrical power consumption. By improving the system efficiency there will be direct reduction of energy. Direct reduction of energy will happen by use of high efficiency synchronous motors, switching devices, by higher frequency of PWM. Indirect reduction of energy consumption by shortening the operation.

## II. RELATED WORK

It has been observed that in every era of industry energy consumption and its saving has become the very important factor to be consider, as the cost of energy is increasing continuously. In general every industry is targeted to break less production and also it is undesirable to stop the production for few milliseconds. It may provide too much loss to the company. If we consider the production of 24 hrs, there is considerable amount of period even if the actual production is off, all machines are in ON state which causes unnecessary energy consumption. So it is very important to save the energy and make the system energy efficient.

There are various ways suggested to save the energy in particular of CNC machining tools such as saving electrical energy by optimizing cutting parameters of CNC machine tools. In which the machining time for the operations turning, facing and undercutting performed on cylindrical component. The operating parameters considered are cutting speed and feed rate that do not violate any of the constraints that may apply to the process and satisfy objective criteria of minimum machining time. By implementation of optimal cutting parameters suggested will lead to reduce the machining time and so the power consumption [1].

Various experiments were performed by experts regarding the strategies for energy saving. In this they have experimented machining using five different machining strategies regarding feed rate and depth of cut. They resulted as even though electrical energy cost is small in relation to other machining costs on a large scale; it confines a large expenditure for a company and consequently considerable cost savings can be made [2].

## III. SYSTEMDESCRIPTION

The system proposed includes 3 phase motors which are used for conveyer belt, in hydraulic pumps and some other motors which all are connected to central processing unit. Non-invasive current transformer is used for measuring the energy consumption of each motor. The one use of this sensor is that we are able to decide whether the motor is under the load or not, so that we can control the motor. They are particularly useful for measuring whole building electricity consumption (or generation for that matter).

The motors and devices are continuously operating even if there is no actual operations are serving. Since these systems cannot switch ON and OFF quickly and are not easily controlled, they are forced to remain ON. Hence there is unnecessary loss of electricity takes place. To reduce this loss of electricity we use the sleep mode concept, which will make the motor to operate at constant speed instead of switching it completely OFF.

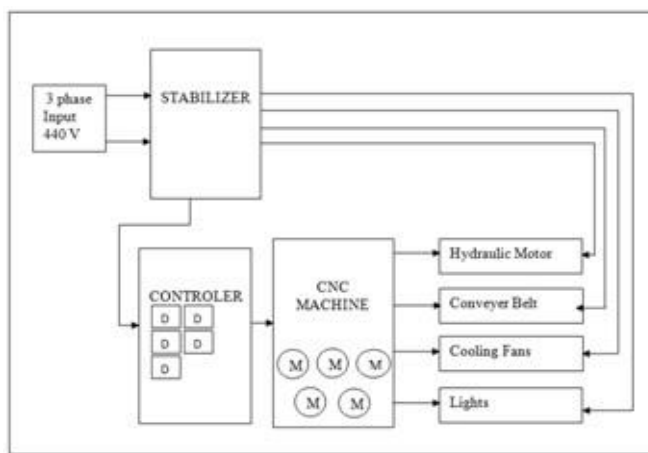

fig1. power consuming equipments.

IV. HARDWARE DESCRIPTION

In the given below block diagram, The block consist of five appliances i.e, motors and drivers, conveyer belts, cooling fans ,light, hydraulic motor is turn on or off which depends upon timer relay using microcontroller.

The system is design using Arduino unoR3. Arduino platform is mainly for two reasons. First, as it is a widely used electronics prototyping platform, thus making it easy to maintain and extend. Second, because there exist many variations in the market thus making it a low-cost solution.The hardware of the system consist of two sensors which are relay timer sensors and non-invasive ac current sensor.

The first sensor is relay timer, it happen when voltage is applied and removed from the coil on time delay relays; the contact can open or close before or after some time delay. The second sensors, non invasive is useful for measuring whole building electricity consumption. The output of the sensors such as timer relay sensors which is used separately for each appliances and the non- invasive ac current sensor module are interfaced to the microcontroller used.

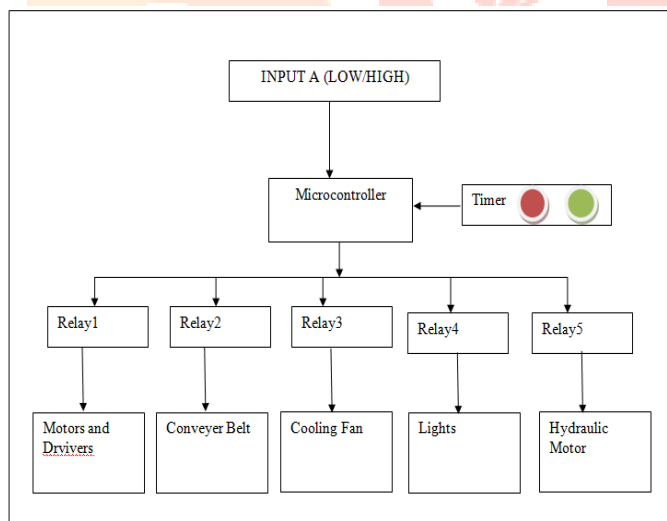

fig2. sleep mode operation model

V. CALCULATIONS

Power Consumption of 5 axis CNC Machines:

Annual savings(kw)=annual operating hour\*saving per hour  
 Annual savings(Rs) =annual savings in Kw\*unit energy price(Rs/kw)

Motor output power	=55 Kw
Nominal speed	=3000 rpm
Motor Efficiency	=93%
Load cycle	=80
Unit energy price (Rs/Kw)	=200-250
Rs/Kw Savings per hour	=0.5530Kw
Usages per day for 1 hour	

Annual operating hour =365hours  
 Annual savings (kW) =365\*0.55  
 30 =201.8450kw  
 Annual savings (Rs) =200\*201.8450kw  
 =40,368Rs  
 Annual savings (Rs) =250\*201.8450kw  
 =50,461.25Rs

Usages per day for 5 hours

Annual operating hour =365\*5hour  
 =1825hour  
 Annual savings (kW) =1825\*0.55  
 30 =1009.2250kw  
 Annual savings (Rs) =200\*1009.2250kw  
 =2, 01,345 Rs  
 Annual savings (Rs) =250\*1009.2250kw  
 =2, 52,306.25 Rs

Usages per day for 10 hour

Annual operating hour =365\*10hours  
 Annual savings (kW) =3650\*0.55  
 30 =2018.4500 kW  
 Annual savings (Rs) =200\*2018.4500 kW  
 =4, 03,690Rs  
 Annual savings (Rs) =250\*2018.4500 kW  
 =5, 04,612.5Rs

VI. DISCUSSION

The motor with 55kw output power and load cycle of 80 is observed. The working hours of the motor are varied from 1hour per day to 10 hours per day. How much energy is saved within these hours is given as in the above calculations. We observed that energy is saved per hours is 0.5530Kw. So, if we used this system per day for 1hour annual savings in (Kw) is 365\*0.5530Kw=201.8450 Kw. Unit energy price (Rs/Kw) is 200-250 Rs/Kw, as per this rating we have annual savings in Rs is 90,369-50,461.25. Likewise the energy saved for 5 hour and 10 hour per day is calculated in above calculations. Downtime plays an important role in finding the effectiveness and productivity of the CNC machines. Downtime means how long the machine was in idle state. [6].

Machining represents one of the main energy-consuming activities in manufacturing industries and energy consumption determines 20% of machine tool operating cost. In order to be able to compute the overall energy consumption, it is necessary to estimate the energy consumption of each considered machine tool functional module (auxiliaries, axis, spindle, chillers, chip conveyor, etc) during different production phases (i.e. work piece set-up, machining, tool changes, work piece approach and rapid axis movements). [7].

VII. RESULTS

For testing the proposed system, the process is when there is no input to the machine then the machine will remain on for some period of time if it won't get any input then the machine will go into sleep mode and there will be a reduction of power consumption and saving of electricity.

Table1. Power savings for 5 axis cnc machines:

Parameters	Unit
Motor output power	55 Kw
Nominal speed	3000 rpm
Motor Efficiency	93%
Load cycle	80

Unit energy price(Rs/Kw)	200-250 Rs/Kw
Savings per hour	0.5530Kw

Table2. Usage per day for 1hour

Annual Operating hour	365
Annual Savings (Kw)	201.8450 Kw
Annual Savings (Rs)	90,369-50,461.25

Table3. Usage per day for 5 hour

Annual Operating hour	1825
Annual Savings (Kw)	1009.2250 Kw
Annual Savings (Rs)	2,01,345-2,52,306.25

Table4. Usage per day for 10 hour

Annual Operating hour	3650
Annual Savings (Kw)	2018.4500 Kw
Annual Savings (Rs)	4,03,690-5,04,612.5

## VIII. CONCLUSION

The project is designed to reduce the power loss in industries by using automatic power saving unit during downtime hours. With the help of this, it will be possible to reduce power consumption during downtime hour and when there will be unavailability of machine handler. With the help of non-invasive sensor, it will be possible to sense a Motor is on or off, on the basis of sensor output microcontroller on or off a motors, fan, light using relay.

## IX. REFERENCES

- [1] V. Janakiraman, K. Suresh, C. Godwin Jose, M. Ramu, 'Saving electrical energy in industry by optimizing cutting parameters of CNC machine tools', Int. J. Chem. Sci.:14(1), 2016, 399-408, ISSN 0972-768X.
- [2] S. Anderbeg, S. Kara, "Energy and cost efficiency in CNC machining", The 7<sup>th</sup> CIRP conference on sustainable manufacturing.
- [3] S.T. Newman, A. Nassehi, R. Imani-Asrai, and V. Dhokia, "Energy Efficient Process Planning for CNC Machining".
- [4] Hinsu Jindal, Rakesh Kumar, Kartik D. Kothari, Modern Techniques in CNC Machines - A Review". International Journal of Advance Engineering and Reasearch Development, 6-June-2014.
- [5] Sushrut S. Pavanaskar, "Improving Energy Efficiency in CNC Machining", 2014.
- [6] Anil C N, Lalitha L. A., Shekar K V, "Survey on the Downtime of the CNC machines and Usage of Raspberry pi".
- [7] Maria Luisa Calvanese, Paolo Albertelli, Andrew Matta, and Macro Taisch Politecnico Milano, "Analysis of Energy Consumption in CNC Machining Centres and Determination of Optimal Cutting Conditions".