

LASER HARP USED AS A MUSICAL INSTRUMENT ON THE PRINCIPLE OF PERSISTENCE OF VISION

Prof.Mohan Kumar
EXTC Department

Hrushikesh Bobhate
EXTC Department
Atharva college of Engineering Mumbai 400095.

Devavrat Ghag
EXTC Department
Atharva college of Engineering Mumbai 400095

Jugal Gore
EXTC Department
Atharva college of Engineering Mumbai 400095

Kajal Bhansali
EXTC Department
Atharva college of Engineering Mumbai 400095

Abstract—The Laser Harp is an electronic musical instrument , using laser beams instead of conventional strings. By breaking the beams, users are able to play notes. A teaching mode feature encourages users to learn certain preset melodies through a simple watch-listen and-repeat routine. The Laser Harp aims to provide a musical instrument that combines simplicity, robustness and interactive capabilities all in one.

The basic working of a laser harp is as follows: A laser beam is shone. A stepper motor with a mirror divides it into nine beams. When one or more of the beams are cut, the light sensor (Light Detecting Resistor, LDR) detects it. According to the corresponding motor positions, it sends signals to the Arduino, which in turn produces the respective notes through a computer or keyboard. A mirror is attached to the motor. The laser beam is directed to the mirror. The motor rotates in steps, hence stepper motor. With every step the motor takes, the position of the mirror changes, deflecting the beam in a different direction every time. The steps take place fast enough for the beams to appear as if they are simultaneously present.

Every beam has a corresponding motor position. When a beam is cut, it reflects onto the sensor, which detects an increase in light intensity. The light sensor then looks for the position of the motor at the instant the beam was cut, and thus identifies the beam in question.

Keywords—Stepper motor, Embedded system, ATmega 328Microcontroller, LDR sensor, Laser.

I. Introduction to Laser Harp :

What is Laser Harp?

The Laser Harp is an electronic musical instrument , using laser beams instead of conventional strings. By breaking the beams, users are able to play notes. A teaching mode feature encourages users to learn certain preset melodies through a simple watch-listen and-repeat routine. The Laser Harp aims to provide a musical instrument that combines simplicity, robustness and interactive capabilities all in one.

The basic working of a laser harp is as follows: A laser beam is shone. A stepper motor with a mirror divides it into nine beams. When one or more of the beams are cut, the light sensor (Light Detecting Resistor, LDR) detects it. According to the corresponding motor positions, it sends signals to the Arduino, which in turn produces the respective notes through a computer or keyboard. A mirror is attached to the motor. The laser beam is directed to the mirror. The motor rotates in steps, hence stepper motor. With every step the motor takes, the position of the mirror changes, deflecting the beam in a different direction every time. The steps take place fast enough for the beams to appear as if they are simultaneously present.

Every beam has a corresponding motor position. When a beam is cut, it reflects onto the sensor, which detects an increase in light intensity. The light sensor then looks for the position of the motor at the instant the beam was cut, and thus identifies the beam in question.

Persistence of vision – this is what enables us to see the beams all at once, since the refreshment rate of the human eye is smaller than the rotation rate of the motor.

An arduino is used with programming to handle the musical notes concerned with each laser beam. An MIDI(Musical Instrument Digital Interface) keyboard or a computer is used to play the musical notes when the laser beams are cut.

The Laser Harp is a compact instrument unlike the traditional harp. It can be used for other applications too such as for laser pattern creation, laser projector, object scanner and security systems.

II. Basic Concept:

A **laser harp** is an electronic musical [user interface](#) and [laser lighting display](#). It projects several [laser](#) beams—and a musician plays these by blocking them to produce sounds-reminiscent of a [harp](#). The laser harp has been popularised by [Jean Michel Jarre](#), and has been a high profile feature of almost all his concerts since 1981. British electronic musician [Little Boots](#) has used a similar instrument in concerts. The British electro jazz band 1201-Alarm feature a laser harp as a main aspect of their live show.

III. Project Working:

A driver is connected to a stepper motor (200 steps per revolution). The driver provides energy to the stepper motor in a way that drives the motor into 200 different positions. If the DIR pin of the driver is at the low logic, i.e. at 0, the laser is kept off. When the pin is set to the high logic, i.e. at 1, the laser beam is generated. The step pin generates the steps with the help of pulses. The stepper motor is placed on an acrylic sheet. The laser is fixed at a position perpendicular to the reflector placed at the end of the motor. Initially the position of the reflector is not fixed. As the laser is turned on, the beam is detected by the calibration LDR. The step counting begins. At step 1, the laser turns on. The beam is visible at this time. It then turns off and after a delay of 5ms, another beam is generated at step 2. In this way, a total of 5 beams are generated. With the help of a reflecting material in hand, these beams are struck. The interference leads to the generation of musical notes. These notes are pre-assigned to the beams with the help of midi codes and are played with the help of Ableton Live.

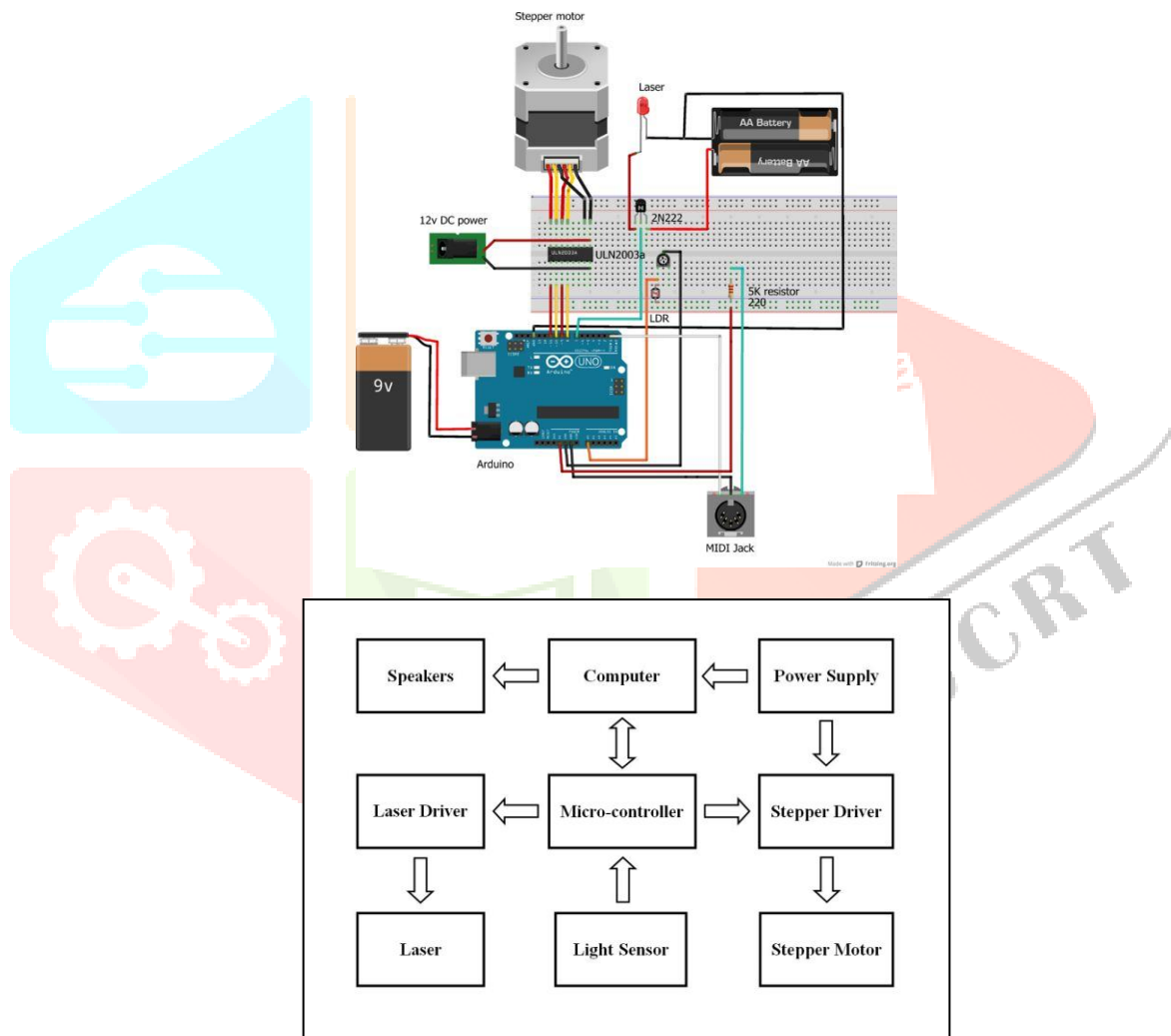

IV. Basic Components Used:

- IC ATMEGA 328 x 1
- USB TO TTL CP2102 x 1
- LASER (upto 300mv) x 1
- StepperMotor (200Steps/revolution)
- Stepper divider

- LDR sensor
- Laser Driver
- Ableton live or FL Studio
- Hairless Midi
- MidiYoke.

1.**Laser:** A laser is a device that emits light through a process of optical amplification based on the stimulated emission of electromagnetic radiation. The term "laser" originated as an acronym for "light amplification by stimulated emission of radiation."

2.**Arduino:** Arduino is an open-source platform used for building electronics projects. Arduino consists of both a physical programmable circuit board (often referred to as a microcontroller) and a piece of software, or IDE (Integrated Development Environment) that runs on your computer, used to write and upload computer code to the physical board.

3.**Stepper motor:** A stepper motor or step motor or stepping motor is a brushless DC electric motor that divides a full rotation into a number of equal steps. The motor's position can then be commanded to move and hold at one of these steps without any position sensor for feedback (an open-loop controller), as long as the motor is carefully sized to the application in respect to torque and speed.

4. **Light sensor:** A Light Sensor is something that a robot can use to detect the current ambient light level - i.e. how bright/dark it is.

5. **Midi:** MIDI (short for Musical Instrument Digital Interface) is a technical standard that describes a communications protocol, digital interface and electrical connectors and allows a wide variety of electronic musical instruments, computers and other related music and audio devices to connect and communicate with one another. A single MIDI link can carry up to sixteen channels of information, each of which can be routed to a separate device.

V.Basic Working

The stepper motor generates the steps for the laser beam. On power supply, the calibration LDR detects the laser light and sets the motor at a horizontal position by rotating in anticlockwise direction. A laser beam is generated at step 1. After a delay of 5ms, another beam is generated. At the end, 5 such beams are generated. By creating an obstruction by striking the beam, the musical note is generated with the help of Midi codes. This musical note is played with the help of Ableton live software.

VI. Applications:

- It supports music production with the help of light.
- Different laser patterns can be created with this technique.
- Laser harp can be used as a Laser Projector.
- It can also be used for scanning of objects.
- It can be used for security purposes.
- It can be used for using as different musical instruments.

VII. Future Scope:

- With a Laser Harp Controller, you can choose between 8, 9, 10 or 12 laser beams, depending on how many tones the melody being played requires
- Your laser beams can be all red, all green, all blue, green and red (in which case red beams designate high notes while all other notes are green (like the black and white keys of the piano), or multicolored (Rainbow mode) if you are using an RGB laser.
- You can switch the tone orientation (starting C tone) from left to right.
- You can switch between three different MIDI banks (C3, C4 and C5 musical scales).
- You can play polyphonic (means you can play several tones at the same time)
- You can connect a Double Footswitch to your Controller and use it for Opening/Closing the Laser Harp and for quick switching between MIDI banks. If the Footswitches are not available, all the functions can be controlled and operated on the Laser Harp Controller box itself.
- Function LEDs on the Laser Harp Controller box and sensor for easier indication and operation in dark areas
- The option of controlling beam spread

VII. Conclusion:

Our project can be implemented in a way as we have presented as well as with the future scope of including gesture control mechanism. Laser harp finds its applications in the music industry involving concepts of engineering. This is a traditional engineering project with various applications. Not only is this project economic but it can be also altered according to the requirements of the laser such as different musical instruments, object detection, security purposes, etc. Thus, this project proves to be an important innovation and practically applicable.

VIII. References:

- G. Ferenc et al (2014) In this paper one particular realization of an electronic musical instrument referred as a laser harp has been presented. The laser harp consists of an array of beams organized in a fan arrangement. In analogy with the plucking of the strings of a harp, laser beams are intended to be blocked to produce sounds.
- [Xiaoling Luo](#) et al (2011) The paper researches laser performances and introduces laser technology application in laser punching, high precision machining and demonstrates laser important role and huge promotion effect in these industries. The paper has certain reference value to laser technology performance research. We are using this technology for our proposed project.
- Magun et al (2006) The intent of this project is to design and created a gestural controller that is instrument-inspired. The imitation is that of a harp. The techniques used to emulate physical strings are presented and the extrapolation of the MIDI parameter velocity is explained Practical results are reported.
- Ling Long, Zhao Ren Lu et al (2013) A design of electronic laser harp based on SCM (the abbreviation for single chip microcomputer) is proposed. It adopts the semiconductor laser transmitter and the receiving tube as a sensor, and uses the laser transmitter emits beams to imitate the 8 strings of harp. The main control chip STC89C52RC collects and processes the signal from receiving tube circuit, then STC89C52RC outputs special signal to produce sound of harp by audio. Compared with the traditional method, this design greatly enhances the anti-interference ability of the system, and it owns a certain degree of innovation and creation in not only the form of performance but also design proposal of system

