

RFID Based Log Register Using Arduino with Inbuilt Memory

V. Divya¹, SK. Masthan², A. Tejaswi³, P. Amaraiah⁴, T Gowthami⁵
 U.G. Student, Department of ECE, CIET, Lam, Guntur^{1,3,4,5}
 Assistant Professor, Department of ECE, CIET, Lam, Guntur²

Abstract: In recent years, there have been rise in the number of applications based on Radio Frequency Identification (RFID) systems and have been successfully applied to different areas as diverse as transportation, health-care, agriculture, and hospitality industry to name a few. RFID technology facilitates automatic wireless identification using electronic passive and active tags with suitable readers. In this paper, an attempt is made to solve recurrent lecture attendance for laboratories monitoring problem in developing countries using RFID technology. The application of RFID to student attendance for labs monitoring as developed and deployed in this study is capable of eliminating time wasted during manual collection of attendance and an opportunity for the educational administrators to capture face-to-face classroom statistics for allocation of appropriate attendance scores and for further managerial decisions.

IndexTerms - RFID, Arduino, Log Register.

I. INTRODUCTION

The project Arduino and RFID Based student log register is a simple and previously we had posted a project using RFID and microcontroller AT89C52 called RFID Based Security System using Microcontroller AT89C52, used for open door. RFID (Radio Frequency Identification) use an electromagnetic field to detect unique tag assigned to object in the vicinity. RFID tag is more secure and conventional because RFID traces tags hidden inside objects unlike bar codes. It distinguishes authorize and un-authorize user in order to maintain monthly weekly or monthly log. RFID is a non-contact, automatic identification technology that uses radio signals to identify, track, sort and detect a variety of objects including people, vehicles, goods and assets without the need for direct contact or line-of-sight contact (as found necessary in bar code technology). RFID technology can track movement of objects through a network of radio-enabled scanning devices over a distance of several METERS. A device called RFID tag, or simply a tag, is a key component of the technology. These are actively used in RFID based access control systems implemented in offices all around. An RFID reader emits a low-level radio frequency magnetic field that energizes the tag. The tag responds to the reader's query and announces its presence via radio waves, transmitting its unique identification data. This data is decoded by the reader and passed to the local application system via middleware. The middleware acts as an interface between the reader and the RFID application system. The system then searches and matches the identity code with information stored in the host database or backend system. In this way, accessibility or authorization for further processing can be granted or refused, depending on results received by the reader and processed by the database.

II. PROPOSED SYSTEM

The proposed system is to take attendance of students through RFID tag and RFID Reader. THEREFORE, this propose gadget gives ensure to parent that, weather the child attending the class or bunk the magnificence. This proposed machine additionally include the switches to display the day and time DESK. SIMILARLY, to this, IR sensor also are used in this device to ensure how a good deal pupil all enter the class room. The main motive in the back of this device is to lessen human efforts, PAPER paintings or lessen the time.

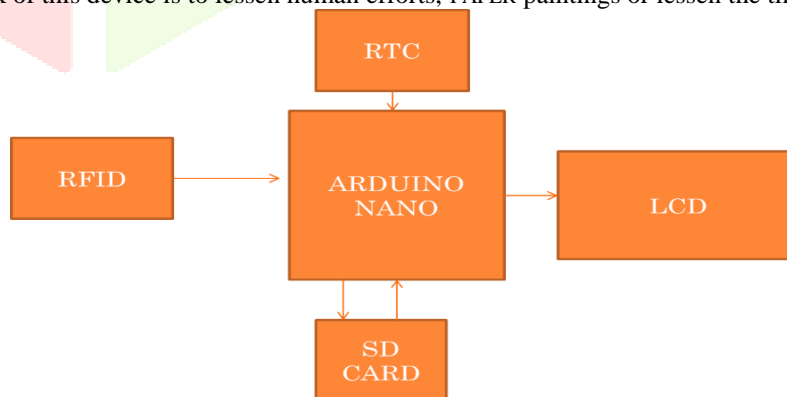

Figure 1: Block diagram of the system

As shown in the above figure1, after making all of the connections of attendance gadget, give the power supply to replace on the circuit. The LCD will presentations, please swipe the card. The statistics stored within the RFID tag is said as the id and attendance of the pupil. While the man or woman locations the cardboard in front of the RFID reader, it reads the statistics and matches with the information stored inside the SD card. The Arduino is preprogrammed with embedded c program language period. While a person positioned the RFID tag to RFID reader then RFID reads tag's information and ship it to SD card after which Arduino compares this facts with described information or records. If data is matched with described information then Arduino increment the attendance with the aid of one of the tag's person and if matched isn't always took place then Arduino shows invalid card on LCD.

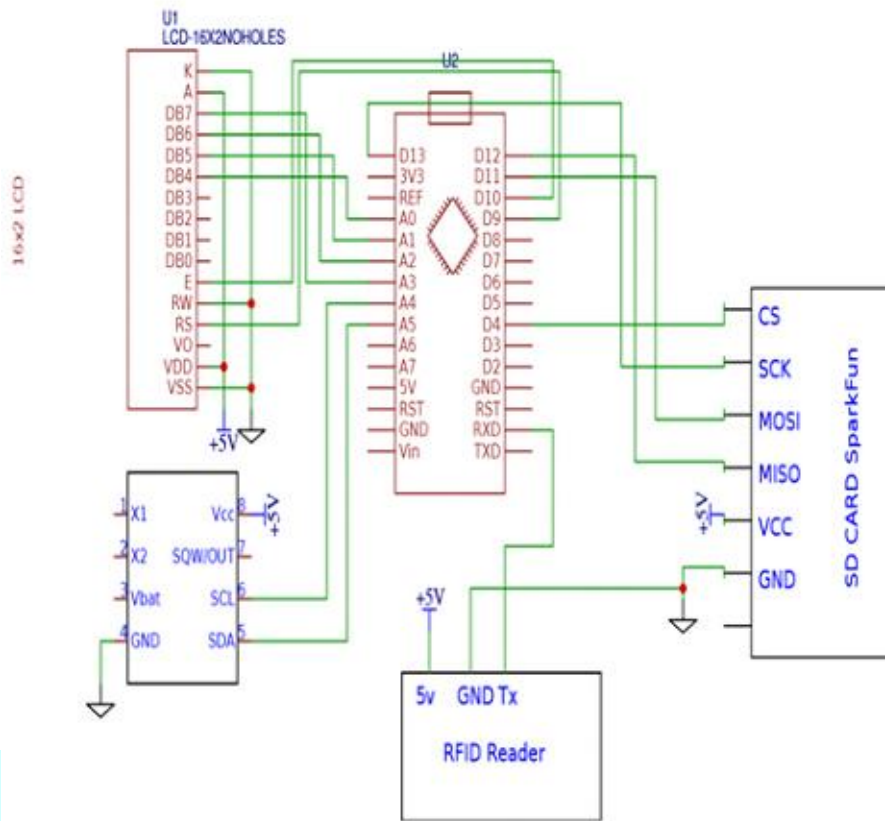

Figure 2: Circuit Diagram

III. HARDWARE DESCRIPTION

The Proposed system consists of Arduino, RFID cards, RFID Reader, LCD, RTC, SD card.

Arduino NANO: The Arduino Nano has a number of facilities for communicating with a computer, another Arduino, or other microcontrollers. The ATmega328P provide UART TTL (5V) serial communication, which is available on digital pins 0 (RX) and 1 (TX). An FTDI FT232RL on the board channels this serial communication over USB and the FTDI drivers (included with the Arduino software) provide a virtual com port to software on the computer. The Arduino software includes a serial monitor which allows simple textual data to be sent to and from the Arduino board. The RX and TX LEDs on the board will flash when data is being transmitted via the FTDI chip and USB connection to the computer (but not for serial communication on pins 0 and 1). A Software Serial library allows for serial communication on any of the Nano's digital pins. The ATmega328P also support I2C (TWI) and SPI communication. The Arduino software includes a Wire library to simplify use of the I2C bus.

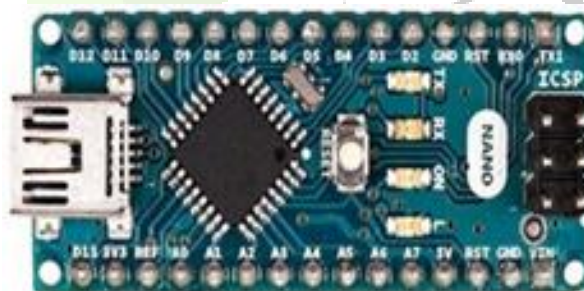

Figure 3: Arduino NANO

The Arduino Nano can be powered via the mini-B USB connection, 6-20V unregulated external power supply (pin 30), or 5V regulated external power supply (pin 27). The power source is automatically selected to the highest voltage source.

RFID tags:



Figure 4: RFID Tags

RFID tagging is an ID system that uses small radio frequency identification devices for identification and tracking purposes. An RFID tagging system includes the tag itself, a read/write device, and a host system application for data collection, processing RFID tags that contain their own power source are known as active tags. Those without a power source are known as passive tags. A passive tag is briefly activated by the radio frequency (RF) scan of the reader. The electrical current is small -- generally just enough for transmission of an ID number. Active tags have more memory and can be read at greater ranges. Increasingly, RFID tagging is used in supply chain management as an alternative to bar code technology. Although more expensive to use than the bar code stickers, RFID tags don't get dirty or fall off or require an unobstructed line-of-sight between the tag and the reader. There are almost endless possible uses for RFID tagging. Injectable ID chips have been used to track wildlife and livestock for over a decade. An injectable RFID tag called the Veri Chip can be used to help medical personnel identify a patient who is unable to speak -- and even provide access to for illicit tracking. The person's medical records. RFID tagging is somewhat controversial because the tags could theoretically be cloned or used.

RFID READER:

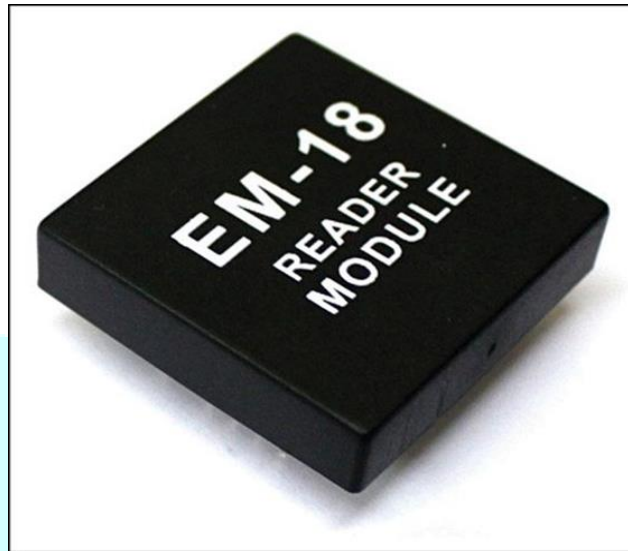

Figure 5: RFID Reader

In this project we used EM-18 RFID reader module operating at 125kHz. The module comes with an on-chip antenna and can be powered with a 5V power supply. The transmit pin (TX) of the module should be connected to receive pin (RX) of Arduino NANO board. FID is a technology similar in theory to bar codes. However, the RFID tag does not have to be scanned directly, nor does it require line-of-sight to a reader. The RFID tag it must be within the range of an RFID reader, which ranges from 3 to 300 feet, in order to be read. RFID technology allows several items to be quickly scanned and enables fast identification of a particular product, even when it is surrounded by several other items. FID tags have not replaced bar codes because of their cost and the need to individually identify every item.

Real Time Clock (RTC):

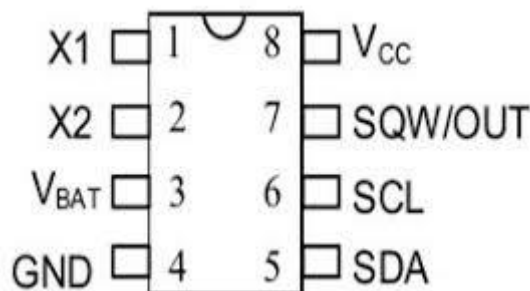

Figure 6: Real Time Clock

- A real-time clock (RTC) is a computer clock (most often in the form of an integrated circuit) that keeps track of the current time.
- Although the term often refers to the devices in personal computers, servers and embedded systems, RTCs are present in almost any electronic device which needs to keep accurate time. A common RTC used in single-board computers is the DS1307.

LCD: Liquid crystal display stands for Liquid Crystal display. Liquid crystal display is finding wide unfold use replacing LEDs (seven section LEDs or other multi segment LEDs) because of the following reasons.

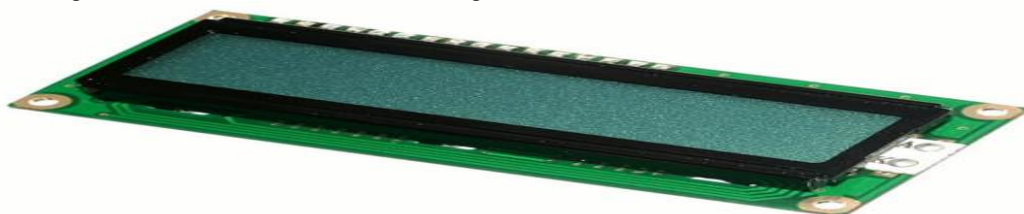

Figure 7: LCD

- i. The declining expenses of LCDs.
- ii. The ability to show numbers, characters and portraits. this is in comparison to LEDs, which can be limited to numbers and a few characters.
- iii. Incorporation of a clean controller into the LCD, thereby relieving the CPU of the mission of refreshing the liquid crystal display. In comparison, the LED ought to be refreshed by using the CPU to maintain displaying the records.
- iv. Ease of programming for characters and snap shots. these additives are “specialized” for getting used with the microcontrollers, this means that that they can't be activated via general IC circuits. they may be used for writing specific messages on a miniature liquid crystal display.

SD Card: SD card is a storage device, which stores the information about the students or employee's technology. A secure Digital card is about the size of a postage stamp and weighs approximately two grams.it is similar in size to an MMC, but smaller than older memory card types, such as a smart media card or compact flash card. An SD card features high data transfer rate and low battery consumption, which are both primary consideration for portable devices. An SD card uses flash memory to provide nonvolatile storage, which means a power source is not required to retain stored data. Both MMC and SD cards provide encryption capabilities for protected content to ensure secure distribution of copyrighted material, such as digital music, video and e-books.SD cards are available with storage capacities as high as 4 GB technology.

IV. ADVANTAGES OF THE PROPOSED SYSTEM

- Lessen paperwork and shop time and money with cell and cloud-based attendance management device.
- Take away replica facts access and errors in time and attendance entries.
- Calculation of go away and praise factors accrued
- Track the attendance of teachers and staff, assign work and manage allocation
- Hold the parents knowledgeable about the pupil's performance via e mail & SMS signals.
- Auto-generate diverse types of reviews of class or pupil attendance.
- Increased security and confidentiality with role-based permissions to users.
-

V. APPLICATION OF THE PROPOSED SYSTEM

- RFID based attendance system can be used in educational institutions, industries, anywhere.
- RFID is emerging technology and is used in applications where authentication is needed.

VI. RESULTS



Figure 8.1: Overall Circuit Component Connection of Proposed System

Table 1 Registered details of Students

S.NO	ROLL.NO	NAME	DATE	TIME
1	1	A. TEJASWI	27/3/18	12:50

2	2	B. HANUSHA	27/3/18	12:50
3	3	B. MANASA	27/3/18	12:50
4	4	CH. SIREESHA	27/3/18	12:50
5	5	D.LAVANYA	27/3/18	12:50
6	6	D.TEJASWINI	27/3/18	12:51
7	7	G. MOUNIKA	27/3/18	12:51
8	8	G. SIVANI	27/3/18	12:51



Figure 8.2 Result

When the student or employee scratch the ID card which included RFID Chip, the reader will read all information regarding that card and stores the data like name, roll number, date, time and display the result on LCD display as shown above figure 8.1.

VII. FUTURE SCOPE

Further improvement can be undertaken on this project for better enhancement: A webcam can be integrated into the system to monitor the person who swaps the card, thus avoiding the problem of a person scanning in for another person. The attendance system can be enhanced to biometric technology which is a full proof technique that captures a person's unique biological or physical features and prevents unauthorized activities.

VIII. CONCLUSION

In this project we are concluding that by using this project, we can reduce the usage of paper and record maintaining work, and it results to simplify the maintenance of lab. It can also be used in various other fields like library, class rooms, seminar halls, it can also be used in toll collection etc. It will also help to avoid manipulation of recorded data.

REFERENCES

- [1]. Pss, Srivignesh, and M. Bhaskar. "RFID and pose invariant face verification based automated classroom attendance system." *Microelectronics, Computing and Communications (MicroCom)*, 2016 International Conference on. IEEE, 2016.
- [2]. Arbain, Norakmar, et al. "LAS: Web-based laboratory attendance system by integrating RFID-ARDUINO technology." *Electrical, Electronics and System Engineering (ICEESE)*, 2014 International Conference on. IEEE, 2014.
- [3]. Olanipekun, A. A., and O. K. Boyinbode. "A RFID Based Automatic Attendance System in Educational Institutions of Nigeria." *International Journal of Smart Home* 9.12 (2015): 65-74.
- [4]. Arulogun, O. T., et al. "RFID-based students attendance management system." *International Journal of Scientific & Engineering Research* 4.2 (2013): 1-9.
- [5]. Azasoo, Julius Quarshie, Felicia Engmann, and KafuiAyite Hillah. "Design of RF based multithreaded RFID student attendance management information system." *Adaptive Science & Technology (ICAST)*, 2014 IEEE 6th International Conference on. IEEE, 2014.
- [6]. 'The RF in RFID' by Daniel Dobkin.
- [7]. Videos from 'JEREMY BLUM ARDUINO' channel in Youtube.