

# DESIGN AND IMPLEMENTATION OF ANTI-THEFT ATM

<sup>1</sup>D RAMBABU, <sup>2</sup>R.DURGA PRASAD, <sup>2</sup>A.RAJESH NAIDU, <sup>4</sup>R.L.R.LOKESH BABU

<sup>1,2,3</sup>Associate prof. Department of Electronics and Communication Engineering, Ramachandra college of Engineering, Eluru, Andhra Pradesh

<sup>4</sup>Assistant prof. Department of Electronics and Communication Engineering, Ramachandra college of Engineering, Eluru, Andhra Pradesh

## ABSTRACT

Automated Teller Machines ATMs are used for different ways, mostly cash withdrawals. ATM users utilize many services on ATM and they will do some billions of transactions. Meanwhile robberies occurring in the ATMs are also high with the lack of security. The main objective of our study is to minimize the robberies occurring in the ATM's. In order to overcome this problem we have come up with a project that uses Raspberry Pi. The hardware components include Web cam to continuously monitor the stipulated area, a motor driver and a motor to open and shut down the doors when a burglar is detected, buzzer to alert the surrounding people and shops. Any person who wants to get into the ATM should provide a valid card near the doors. When the card is inserted, if it is valid the doors get opened else not. If burglars or thief's try to destroy and theft the ATM and once if the vibration is sensed, then information is passed to Raspberry Pi. Then to close the door of ATM the DC Motor is used. Thereby alerting the nearby public and bank authorities the buzzer also rings while the camera continuously monitors the whole ATM. The proposed method or system ensures to develop the advanced ATM anti-theft system. In this project a cost effective and an advance approach for ATM security has been proposed. It can be installed at some hidden place in the ATM so that it cannot be approached or destroyed by thieves. From existing ATM intrusion and theft control systems, this proposed system is distinctive in many ways. In future this can also be extended by sending an SMS alert to the nearest Police Station and also a relay can be used to trigger the gas inside the ATM to make the thief unconscious.

**KEYWORDS:** Vibration Sensor, Motor, Relay, Rfid, Buzzer, Gsm, Camera, And Raspberry Pi.

## INTRODUCTION

As we daily see in news as many robberies are happening around India. ATM users utilize many services on ATM and they will do some billions of transactions. So due to the lack of security these robberies have been notifying every day in different places so, these incidents made me to think about having a high surveillance security system by using the raspberry pi. The proposed system uses the motion sensor to detect the unauthorized access and entry in to the premises, as the motion detect camera takes the real time image & send it to the user for analyzing further so that user can take the necessary actions, for this process we use different components like dc motor which is used to shut the door, the USB Camera captures the image and sends it to the USB port of the Raspberry Pi board.

## LITERATURE SURVEY

The existing project deals with the prevention of ATM theft from robberies by overcoming the drawback found in existing technology in our society. Here the Vibration Sensor is used whenever robbery occurs, to sense vibration produced from ATM machine. Using the vibration sensor, to process the real time data collected, this system uses Arduino controller based embedded system. Once the vibration is sensed, that information is passed over zigbee channel to the ARM11 based master device where alarm

sound starts from the buzzer. To close the door of ATM DC Motor is used. A relay will be triggered to leak the gas inside the ATM to bring the thief or burglar into unconscious stage. Camera is always in processing and will send video continuously to the PC and it will be saved in computer. To capture the robber occur time, RTC is used and that will send the robbery occur time to the nearby police station and corresponding bank with the message through the GSM. This will prevent the robbery from causing and the person involved in robbery can be easily carried.

## BLOCK DIAGRAM AND DESCRIPTION

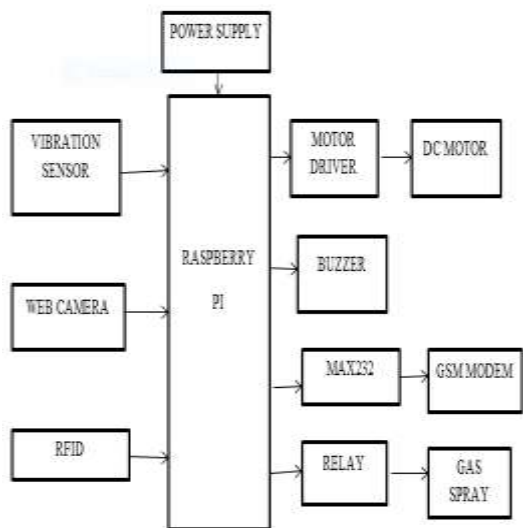

Figure: 1 schematic diagram of ANTI-ATM using arm11 and raspberry pi

**TOOLS REQUIRED:**

- Power supply
- Raspberry pi
- Vibration Sensor
- Web camera
- MAX 232
- Buzzer
- GSM technology
- Relay
- Dc motor
- RFID

**POWER SUPPLY:**

The Power Supply is a Primary requirement for the project work. The required DC power supply for the base unit as well as for the recharging unit is derived from the mains line. For this purpose centre tapped secondary of 12V-0-12V transformer is used. From this transformer we getting 5V power supply. In this +5V output is a regulated output and it is designed using 7805 positive voltage regulator. This is a 3 Pin voltage regulator, which can deliver the current up to 800 milliamps.

Rectification is nothing but the process that renders an alternating current or voltage into a unidirectional one. ‘Rectifier’ is the component which is used for rectification. A rectifier permits the current to flow only during positive half cycles of the applied AC voltage. Thus, pulsating DC is obtained to obtain smooth DC power additional filter circuits required.

**CIRCUIT DIAGRAM:**

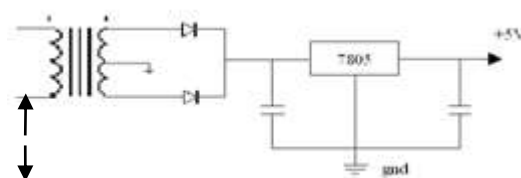

POWER SUPPLY

Based on your requirements, you can continuously adjust the output voltage with a variable regulated power supply, also called a variable bench power supply. The recommended way to test a project is varying the output of the power supply after having double checked parts placement against circuit drawings and the parts placement guide. This type of regulation is ideal when you want a simple variable bench power supply. Most of all, this is quite important because one of the first projects a hobbyist should undertake is the construction of 10 A variable regulated power supply.

While a dedicated supply is quite handy e.g. 5V or 12V, it’s much handier to have a variable supply on hand, especially for testing. Most digital logic circuits and processors need a 5 volt power supply. To use these parts we need to build a regulated 5 volt source. Usually we start with an unregulated power supply that is ranging from 9 volts to 24 volts DC (A 12 V power supply is included with the Beginner Kit and the Microcontroller Beginner Kit.). We use a LM7805 voltage regulator IC (Integrated Circuit) to make a 5 volt power supply. The IC is shown below.

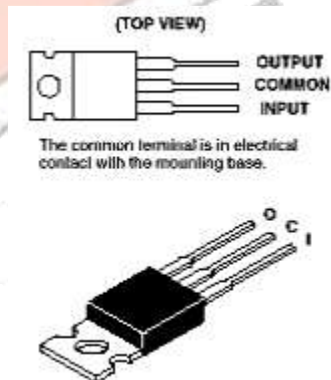
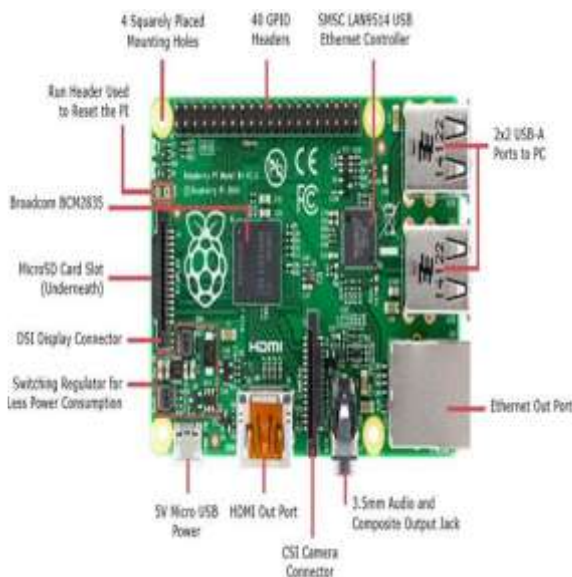

Fig. Positive Voltage Regulators

**RASPBERRY PI:**



Three basic types of Sensors are used to measure vibration:

1. Displacement Sensors
2. Velocity And Acceleration Sensors
  - Displacement sensors help to measure changes in distance between machines stationary housing and rotating element.
  - Velocity and acceleration sensors, helps in measuring the acceleration or velocity of whatever element the sensors attached to, which is usually some external part of the machine frame.

Raspberry Pi is nothing but a credit-card-sized computer that plugs into your keyboard and TV. Also, it can be used in electronics projects as a capable little computer, and for many of the things that your desktop PC does, like word processing, spreadsheets, playing games, and browsing the internet.

**Raspberry Pi 3:**

Operating system	Raspbian Fedora Ubuntu MATE Kali Linux Ubuntu Core Windows 10 IoT Core RISC OS Slackware
System-on-chip used	Broadcom BCM2837
CPU	1.2 GHz 64/32-bit quad-core
Memory	1 GB LPDDR2 RAM at 900

**FEATURES:**

- Twice as many USB ports
- Better power management
- Locking micro SD card slot
- 40-pin connector
- Same low price

**SENSORS:**

**VIBRATION SENSOR:**

**MOTOR:**

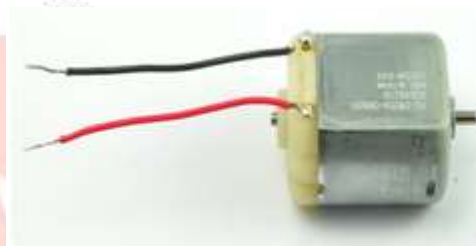

The L293 and L293D are quadruple high-current half-H drivers. Here we learn about hybrid bridges (H-BRIDGE). The h-bridges which are mainly used in change of polarities. There are two polarities in every motor. In L293D two h-bridges are present. Four transistors are present in each h-bridge. If we give logic bits 1, 0 then current flow is Vcc to motor positive after that motor positive to negative and then flows to ground. Then motor rotates in one direction. When we change the logic bits as 0, 1 then the current flow is from Vcc to motor negative and after that motor negative to positive and then it flows to ground. Then the motor rotates in opposite direction. Vcc and ground are short if we give logic bits 1, 1. So now the motor does not rotate. The motor does not start, if we give logic bits 0,0 because two pins are given to zero.

The L293 is designed in such a way that it provides bidirectional drive currents of up to 1 Amp at voltages from 4.5 Volts to 36 Volts. And the L293D is designed in such a way that it provides bidirectional drive currents of up to 600-mA at voltages from 4.5 Volts to 36 Volts. Both these devices are designed to drive the inductive loads such as solenoids, relays, bipolar stepping and dc motors, including other high-voltage/high-current loads in positive-supply applications. All the inputs are TTL compatible. With a Darlington transistor sink and a pseudo-Darlington source, each output is a complete totem-pole drive circuit. Drivers are enabled in pairs such as drivers 1 and 2 are enabled by

1,2EN and drivers 3 and 4 are enabled by 3,4EN. The associated drivers are enabled and their respective outputs are active and are in phase with their inputs when the input is high. And similarly when you give the low enable input, those drivers are disabled and their outputs are in the high-impedance state and are off. Each pair of drivers forms a full-H (or bridge) reversible drive with the proper data inputs and makes it suitable for solenoid or motor applications.



**RELAY:**

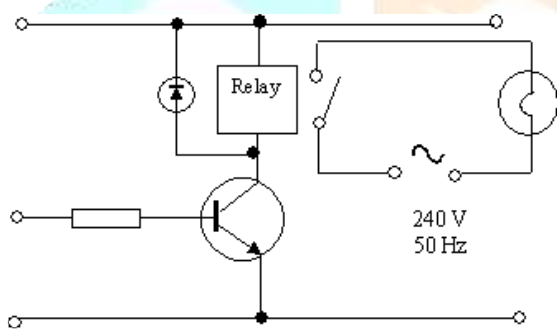

A relay is called as an **electrically operating switch**. Magnetic field is created when current flows through the coil of the relay and that attracts a lever and changes the switch contacts. The current through the coil can be ON or OFF. So these relays have 2 switch positions and they are double through (changeover) switches.

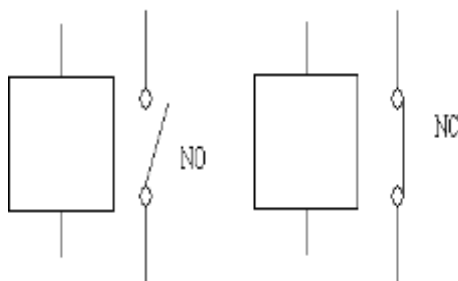

**Fig: normally open Fig: Normally close**

Notice that there are two different kinds:

- **NO** – normally open. The contacts are open until the coil of the relay is energised, whereupon they are closed to complete the outside circuit.
- **NC** - normally closed. The contacts are closed until the coil of the relay is energised, whereupon they are opened to break the outside circuit, switching it off.

- Many relays have **multiple contacts**, half of which are NO and half NC

**RFID:**



- **RFID** stands for Radio-Frequency Identification. The acronym refers to small electronic devices that consist of a small chip and an antenna. The chip typically is capable of carrying 2,000 bytes of data or less
- RFID belongs to a group of technologies referred to as Automatic Identification and Data Capture (AIDC).
- AIDC methods automatically identify objects, collect data about them, and enter those data directly into computer systems with little or no human intervention.

**BUZZER:**



**Fig. Buzzer**

- A beeper or buzzer is an electronic device which is usually a signaling device typically used in household appliances such as a microwave oven, automobiles, or game show.
- It commonly consists of a number of sensors or switches connected to a control unit that determines a preset time has lapsed or which button was pushed and also usually illuminates a light on the control panel or appropriate button, and in the form of a intermittent or continuous buzzing or beeping sound it sounds a warning.

**WEB CAMERA:**





PROJECT OVERVIEW:

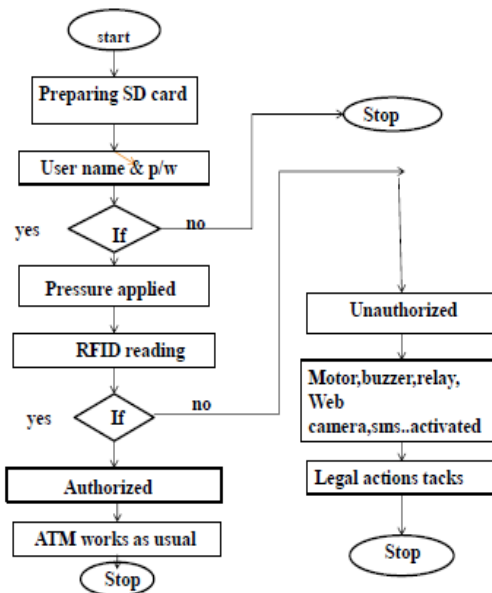

SPECIFICATIONS:

- Brightness, Contrast, Hue, Saturation, Gamma, Whit
- Environment : Indoor, Outdoor
- Frame Rate : Up to 30 fps
- 30 Mega pixels (3264X2448) interpolated
- 1/7 inch CMOS sensor
- Lens view angle: 54 degree
- Power consumption: 160mW typical....

FEATURES:

- Ideally designed to work well with both laptop and desktop
- Adjustable lens for accurate image shooting
- Includes variety of image control
- Auto white balance and zoom function.

GSM MODEM:

A GSM (Global System for Mobile communications) modem is a specialized type of modem which operates over a subscription to a mobile operator by accepting a SIM card, just like a mobile phone. For both sending and receiving MMS and SMS messages, a new version of NowSMS is available. It supports the ability to use Android phones as GSM modem devices.

To split a frequency into time slots, these GSM systems use TDMA. The most useful thing to know about the GSM (Global System for Mobile communications) is that it is an international standard. GSM is the only type of cellular service which is available for you when you travel in Europe and many other parts of the world.

INTERFACING:

Raspberry pi is interfacing with various modules:

GPIO PINS COMPONENT

S . no	PIN	component
1	4	buzzer
2	18	Vibrating sensor
3	26	relay
4	20,21	motor

RESULT:

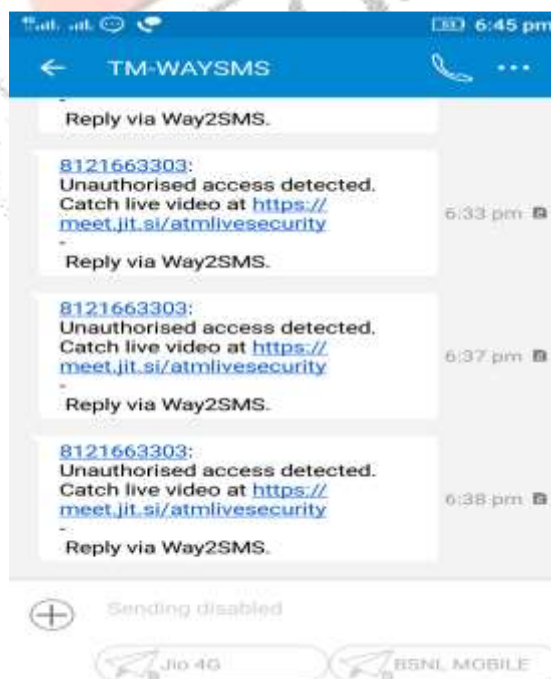

CONCLUSION:

This project - Design And Implementation Of Anti-Theft Atm Machine Using Raspberry PI has been designed and

tested successfully. By integrating features of all the hardware components, it has been developed well and software used and tested. Every module has been placed carefully and their presence has been reasoned out thus contributing to the best working of the unit. Secondly, the project has been successfully implemented using highly advanced RASPBERRY PI Processor board and with the help of growing technology.

#### **FUTURE SCOPE:**

In future, we can also record these live streaming data by connecting external memory storage as the storage space is less.

The smart surveillance system has been designed aiming to fulfil the needs of the user for particular surveillance area. It has countless applications and can be used in different environments.

For instance, to be aware of the activity being happened to any person working in industry then it can be used at their own working places, in their absence, while at another instance it can also be used for the purpose of spying at storage houses, bank lockers.

Another important application is, it can be used to provide information to the user by notification about what is happening in surveillance area. In future, it can be also extended by face recognition and biometric.

#### **REFERNCES:**

- [1] Wireless Medical Technologies: A Strategic Analysis of Global Markets [online]. International Telecoms Intelligence.
- [2] G. Y. Jeong, K. H. Yu, and Kim. N. G. Continuous blood pressure monitoring using pulse wave transit time. In International Conference on Control, Automation and Systems (ICCAS), 2005.
- [3] K. Hung, Y. T. Zhang, and B. Tai. Wearable medical devices for telehome healthcare. In Procs. 26th Annual International Conference on the IEEE EMBS, 2004.
- [4] Fang, Xiang et al: An extensible embedded terminal platform for Information and Automation (ICIA), wireless telemonitoring, 2012 International Conference on Digital Object Identifier: 10.1109/ICInfA.2012.6246761 Publication Year: 2012 , Page(s): 668 - 673.
- [5] Majer, L., Stopjaková, V., Vavrinský, E.: Sensitive and Accurate Measurement Environment for Continuous Biomedical Monitoring using Microelectrodes. In: Measurement Science Review. - ISSN 1335- 8871. - Vol. 7, Section 2, No. 2 (2007), s. 20-24.
- [6] Majer, L., Stopjaková, V., Vavrinský, E.: Wireless Measurement System for Non-Invasive Biomedical Monitoring of Psycho Physiological Processes. In: Journal of Electrical Engineering. - ISSN 1335-3632. - Vol. 60, No. 2 (2009), s. 57-68.

