

Harmonic Mitigation Technique of Active Power Filter

¹Sumita Debiprasad Chakraborty, ²Dr.S.Nigam, ³Dr.Naimish Zaveri

¹PhD Scholar - AISECT University, ²Professor- AISECT University, ³HOD & Professor- CKPCET

¹Electrical Engineering Department

AISECT University-Bhopal, India

Abstract— Harmonic distortion is a form of electrical noise. It is a superposition of signals, which are of multiples of fundamental frequency. Proliferation of large power electronic systems results in increased harmonic distortion. Harmonic distortion results in reduction of power quality and system stability. This paper presents fuzzy control applicable for active power filter for three-phase systems, which are comprised of nonlinear loads. The results of the computer simulation prove that the injected harmonics are greatly reduced, system efficiency and power factor are improved.

Keywords— Fuzzy logic current controller, Harmonic current compensation, Power quality, Shunt active filter.ANN.

I. INTRODUCTION

Harmonics contamination is a serious and a harmful problem in Electric Power System. With the development of power electronics, the converters are widely used in the power supply devices and control application. These Non-linear loads draw currents that are non-sinusoidal and thus create voltage drops in distribution conductors. Typical non-linear loads based on solid-state converters are like UPS, SMPS etc Active Power filtering constitutes one of the most effective proposed solutions. Active power filter (APF) can solve problems of harmonic and reactive power simultaneously.

Shunt active filter (SAF) is one among the various types of custom power devices proposed to improve the power quality [2]. Harmonic extraction is the process in which, reference current is generated by using the distorted waveform. Many theories have been developed such as p-q theory (instantaneous reactive power theory), d-q theory, PLL with fuzzy logic controller, neural network etc..

The active filter used to compensate for the nonlinear load is a three-phase inverter. The Shunt Active Filter (SAF) is controlled by a Proportional- Integral (PI) controller and FC. They are used to shape the line current to be in phase and of the same shape as the supply voltage. The three-phase SAF configuration is simulated using MATLAB/SIMULINK. The effect of SAF on harmonic reduction is also presented.

The controller is the core of the active power filter operation and has been the subject of numerous research in recent years [9], [10].The conventional control scheme to generate pulses, which is based on hysteresis or pwm logic control, presents several drawbacks. To improve the active power filter performance, the tendency has been to use intelligent control techniques, particularly fuzzy logic controllers. Recently, the use of fuzzy logic controllers in power electronics applications has generated considerable interest [5], [6]. The principal advantages of these controllers are robustness, ability to control nonlinear systems, absence of the need for accurate mathematical model, etc.

II. SHUNT ACTIVE POWER FILTER

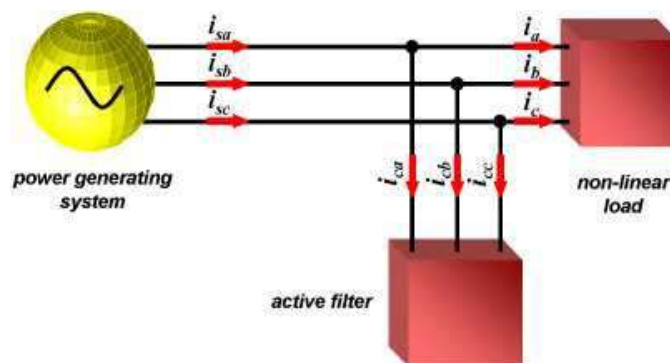

Figure.1 Shunt Active Power Filter

The controller of the shunt active filter is concise and requires less computational efforts than many others found in the literature. It is formed by a dc voltage regulator, a synchronizing circuit and a compensating current reference box. Here, the PWM current control is considered as part of the power converter.

A shunt active power filter that achieves low current total harmonic distortion THD, reactive power compensation, and power factor correction is presented. The topology is based on IGBT's voltage inverter, intended to damp harmonics produced by a diode rectifier. The main paper's contribution is the use of the notch filter method, consisting solely of two serial band-pass filters, for reference currents calculation, and the application of fuzzy logic for better active filter current control accuracy.

Damping harmonics devices must be investigated when the distortion rate exceeds the thresholds fixed by the ICE 61000 and IEEE 519 standards.

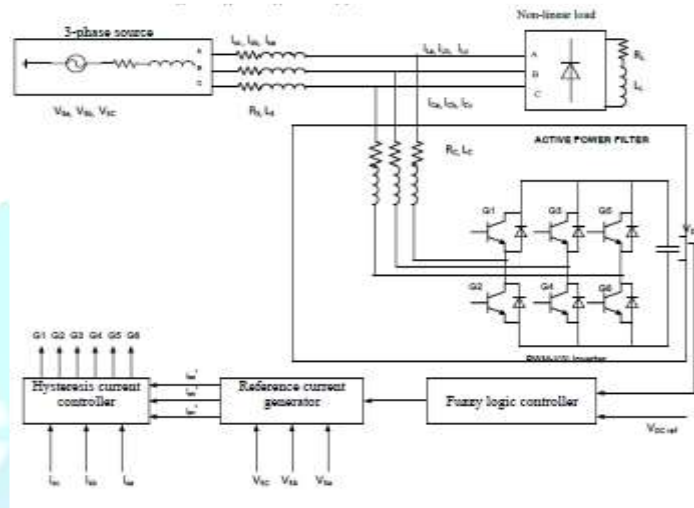

Figure 2. Block diagram of Shunt Active Power Filter with proposed FLC

III . CONTROL STRATEGIES

A. Synchronous reference frame detection method

The first control strategy used in this work to compensate harmonic currents is based on the synchronous reference frame detection method. The principle of this method is described below [5]. The three phase currents i_a , i_b and i_c are transformed from three phase (abc) reference frame to two phase's ($\alpha - \beta$) stationary reference frame currents i_α and i_β using:

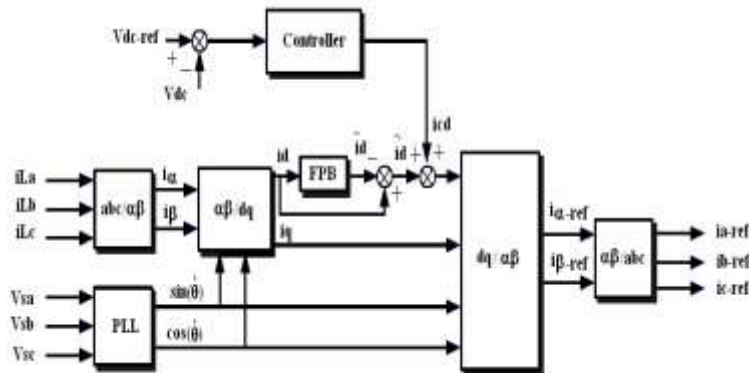

Figure 3 Synchronous reference frame detection method

B. Synchronous current detection method

The second control strategy is inspired of the synchronous detection reference currents method [10]. It is based on the measuring of the source voltages (V_{sa}, V_{sb}, V_{sc}) given by

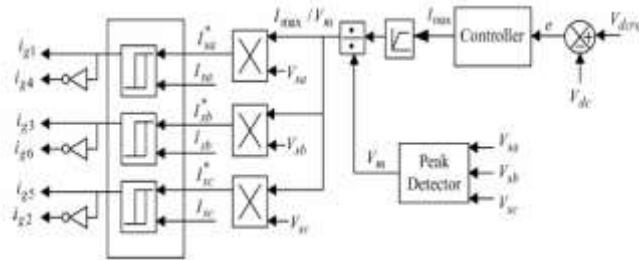

Figure 4. Synchronous current reference detection method

IV.HARMONIC CURRENT CONTROL METHOD

Hysteresis current control is a method of generating the required triggering pulses by comparing the error signal with that of the hysteresis band and it is used for controlling the voltage source inverter so that the output current is generated from the filter will follow the reference current waveform is shown in Figure 3.

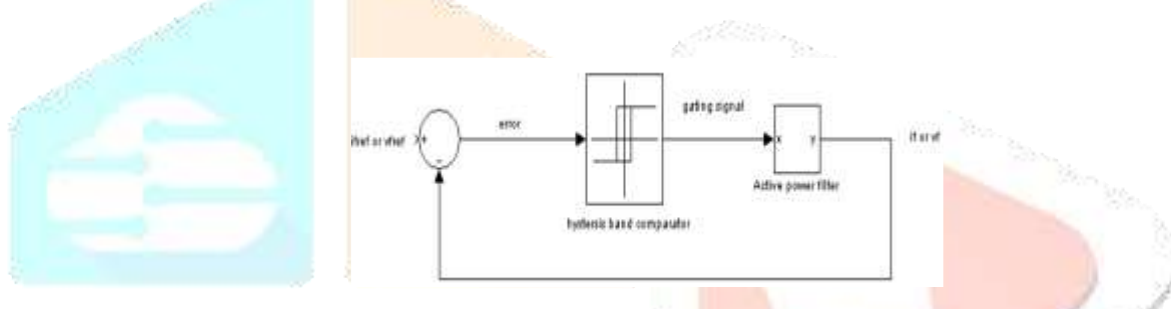

Figure 5. Hysteresis Control

Fuzzy Control Application

Fuzzy logic serves to represent uncertain and imprecise knowledge of the system, whereas fuzzy control allows taking a decision even if we can't estimate inputs/outputs only from uncertain predicates [15, p. 16]. Figure 8 shows the synoptic scheme of fuzzy controller, which possesses two inputs: the error (e), ($e = iref - if$) and its derivative (de), and one output: the command (cde).

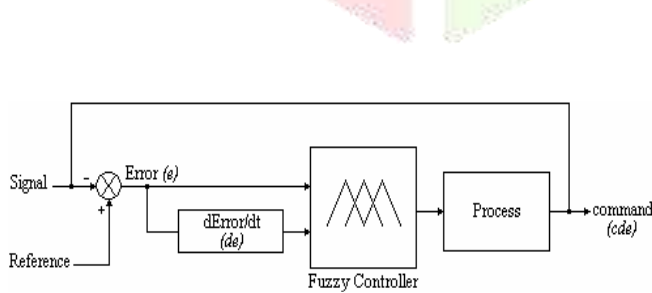

Figure 5. Fuzzy controller synoptic diagram.

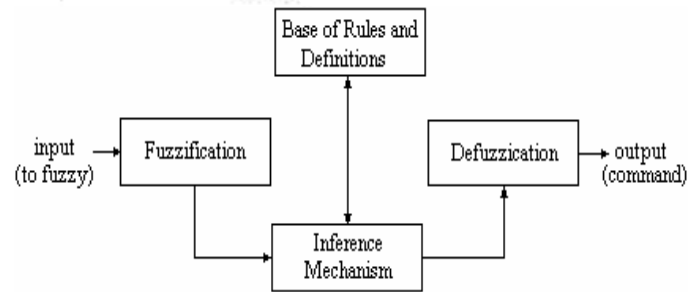

Figure 6. Fuzzy control construction.

Figure 6. illustrates stages of fuzzy control in the considered base of rules and definitions: fuzzyfication, inference mechanism, and defuzzification.

Fuzzy logic current controller

The main component of an active filter is the current controller. Generally the classical hysteresis controller is used to generate pulses to the PWM inverter; it is very stable and generates a minimum noise. Recently, fuzzy logic controllers (FLCs) have been interest a good alternative in more application. The advantage of fuzzy systems are that they do not need an accurate mathematical model, they can work with imprecise inputs, can handle non-linearity, and they are more robust than conventional nonlinear controllers [12],[13].

Fuzzy logic control is the evaluation of a set of simple linguistic rules to determine the control action. To develop the rules of the fuzzy logic, we need good understand of the process to be controlled, but it does not require a complicated mathematical model. The desired switching signals for the filter inverter circuit are determined according to the error in the filter current. In this case, the fuzzy logic current controller has two inputs, named error e and change of error de and one output named s . Here the error e and change of error de are the

input variable for the system [18]. To convert it into linguistic variable, we use three fuzzy sets:

N (Negative), ZE (Zero) and P (Positive). Figure 8. shows the membership functions used in fuzzification.

The fuzzy controller for every phase is characterized for the following:

- Three fuzzy sets for each input,
- Five fuzzy sets for each output,
- Triangular and trapezoidal membership functions,
- Implication using the “min” operator,
- Mamdani fuzzy inference mechanism based on fuzzy implication.
- Defuzzification using the “centroid” method.

The linguistic rules for the fuzzy current controller are as follows:

1. If error is Negative and error rate is Negative Then output is Big Negative,
2. If error is Zero and error rate is Negative Then output is Positive,
3. If error is Positive and error rate is Negative Then output is Big Positive,
4. If error is Negative and error rate is Negative Then output in Big Negative,
5. If error is Zero and error rate is Zero Then output is Zero,
6. If error is Positive and error rate is Zero Then output is Big Positive,
7. If error is Negative and error rate is Positive Big Then output is Big Negative,
8. If error is Zero and error rate is Positive Then output is Negative,
9. If error is Positive and error rate is Positive Then output is Big Positive.

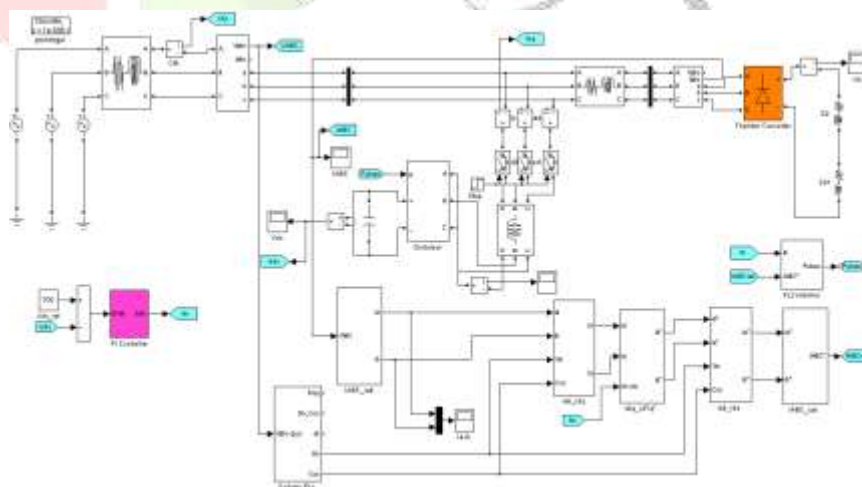

Figure 7. Shunt active filter based on Fuzzy current controller

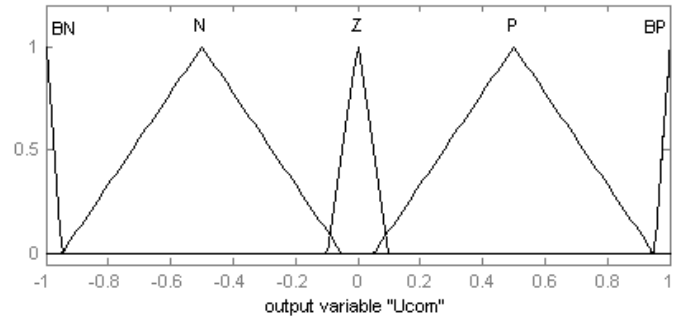
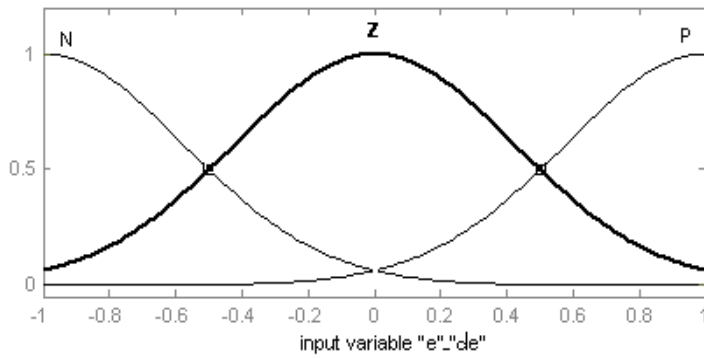

Figure 8. Membership function for the inputs and output variables

The generation process of switching signals is given by Figure 9.

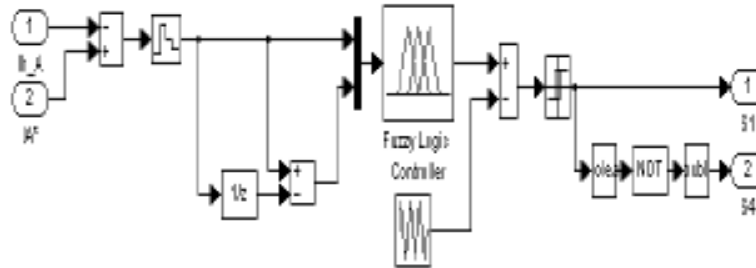

Figure 9. Synchronous current reference detection method

Simulation software

For simulation studies, we used SIMULINK toolbox under MATLAB software in order to model and test the system under investigation.

V. SIMULATION RESULTS AND DISCUSSION

The purpose of the simulation is to show the effectiveness of the shunt active filter using intelligent controllers (fuzzy logic and ANN current controllers) to reducing the harmonic currents produced on the load side under ideal voltages conditions. The model parameters used for simulation are:

Voltage source $V_s=220V$, Frequency $F_s=50Hz$, Resistor $R_s=0.1m\Omega$, Inductance $L_s=0.0002mH$, Resistor $R_{ch}=48.6\Omega$, Inductance $L_{ch}=40mH$, DC Voltage $U_{dc-ref}=700V$, Capacitance $C_{dc}=3000\mu F$, Resistor $R_c=0.27m\Omega$, Inductance $L_c=0.8mH$.

Figure 8 shows the voltage source and line current before compensation

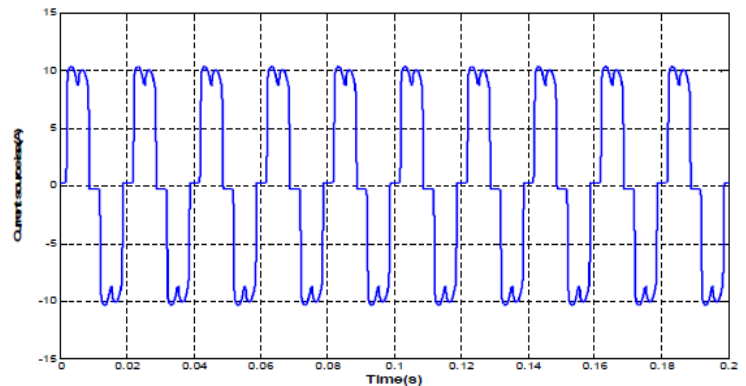
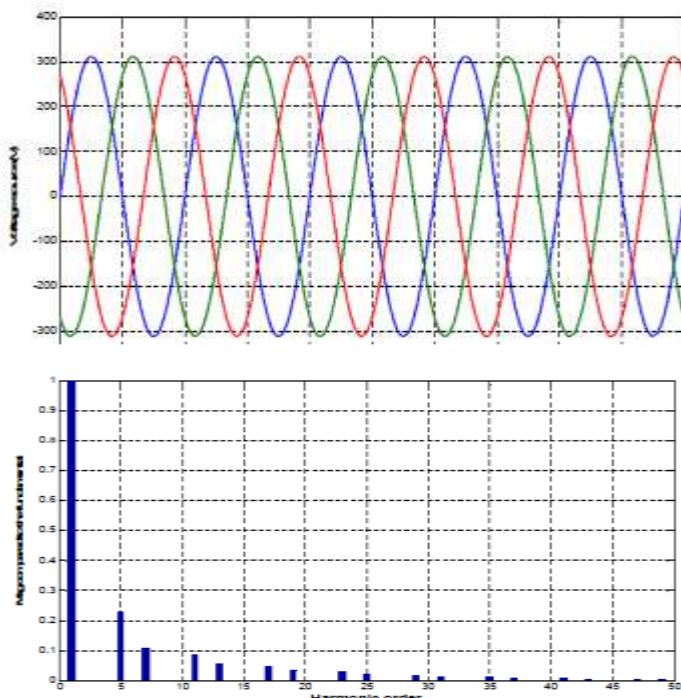

Figure 10. Voltage source and line current before compensation

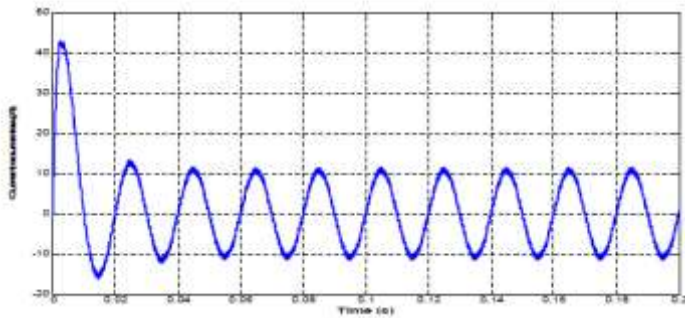

Figure 11. Source current spectrum before compensation

Figure 12. Source current using Fuzzy Logic controller

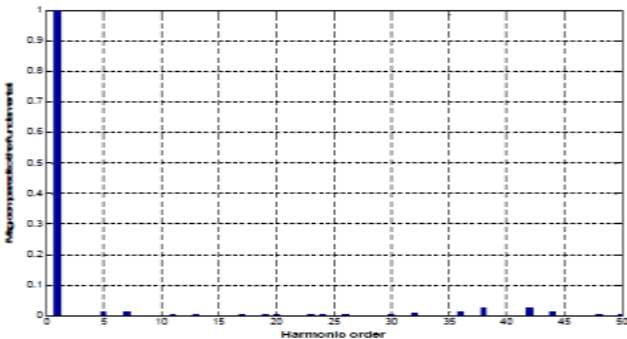

Fig.13 Source current spectrum THD 2.28% using Fuzzy Logic controller

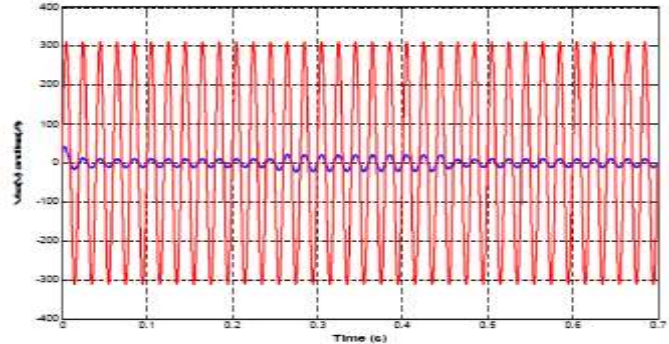

Fig. 14 Current and source voltage using Fuzzy Logic controller

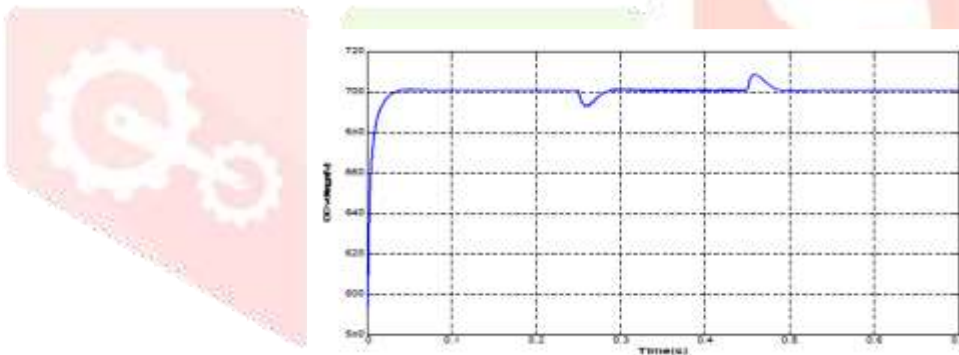

Figure. 15 DC capacitor voltage

VI.CONCLUSION

In this paper, a three-phase three-wire shunt active filter based on intelligent controllers using two control strategies is proposed to compensate current harmonics. The first controller based on FLC use the synchronous reference frame detection strategy. The second controller based on ANNs use the synchronous current detection strategy. The dc-link voltage is regulated using a proportional integral voltage controller with fast dynamic response in case of load current variation. The Simulation results obtained show the robustness and the effectiveness of the two proposed intelligent controllers. After compensation the source current is balanced, sinusoidal and in phase with line voltage source. The harmonic spectrum shows that the THD is very acceptable and respect IEEE standard Norms.

VII.REFERENCES

[1] Jidong Wang, "Simulation of three-phase three-wire shunt active power filter", *International Journal of Sciences and techniques of automatic Control & Computer engineering*, Volume 3,N°1, pp. 942-955, (2009).

- [2] Udom. Khruathep, Suittichai Premrudeepreechacharn, Yuttana Kumsuwan : “Implementation of shunt active power filter using source voltage and source current detection”, *IEEE*, pp.2364-2351, (2008).
- [3] Reyes H. Herrera, Patricio Salemeron, Hoyosung Kim, “Instantaneous Reactive Power Theory Applied to Active Power Filter Compensation: Different Approaches, Assessment, and Experimental Results”, *IEEE, Trans. on Industrial Electronics*, pp. 184- 196, (2008)
- [4] Chandra A, Singh B, Al-Haddad K, “An improved control algorithm of shunt active filter for voltage regulation, harmonic elimination, power factor correction, and balancing nonlinear loads”, *IEEE T Power Electr*, pp. 495-503, 2000.
- [5] S. Bhattacharya, D. Divan, “Synchronous frame based controller implementation for a hybrid series active filter systems”, *IEEE*, pp. 2531-1995, (1995).
- [6] A. Hamadi, K. El-Haddad , S.Rahmani, H.Kankan, “Comparison of fuzzy logic and proportional integral controller of voltage source active filter compensating current harmonics and power factor”, *IEEE, International conference on industrial technology(ICIT)*, pp. 645-650, (2004).
- [7] C. N. Bhende, S.Mishra, “TS-fuzzy-controlled active power filter for load compensation”, *IEEE, Transactions on Power Deliv,21*, pp. 1459-1465, (2006).
- [8] M. Sarra, K. Djazia, A. Chaoui and F. Krim; “Three-phase active power filter with integrator proportional control”, *3rd International Conference on Electrical Engineering*, pp. 506-511, (2009).
- [9] J. Mazumdar, R. G. Harley, G. K. Venayagamoorthy, “Synchronous reference frame based active filter current reference generation using neural networks”, *IEEE*, pp. 4404-4409,(2008).
- [10] Das, J. C. “Passive Filters: Potentialities and Limitations”. *IEEE Trans. Ind. Applicat.*, 40, No. 1 (2004), 232-241.
- [11] Peng, F.Z., Akagi, H. and Nabae, A. “A New Approach to Harmonic Compensation in Power Systems: A Combined System of Shunt Passive and Series Active Filters”. *IEEE Trans. Ind. Applicat.*, 26, No. 6 (1990), 983-990.
- [12] Morán, L.A., Fernandez, L., Dixon, J.W. and Wallace, R. “A Simple and Low-cost Control Strategy for Active Power Filters Connected in Cascade”. *IEEE Trans. Ind. Electron.*, 44, No. 5 (1997), 621-629.
- [17] Lin, B.R. and Yang, T. Y. “Analysis and Implementation of a Three-level Active Filter with a Reduced Number of Power Semiconductors.” *IEE Proc. Electric Power Applicat.*, 152, No. 5, (2005),
- [18]Chennai Salim and Benchouia Mohamed Toufik” Intelligent Controllers for Shunt Active Filter to Compensate Current Harmonics Based on SRF and SCR Control Strategies”
International Journal on Electrical Engineering and Informatics - Volume 3, Number 3, 2011
- [19] Dell'Aquila, A., Delvino, G., Liserre, M. and Zanchetta, P. “A New Fuzzy Logic Strategy for Active Power Filter.” *IEE Conf. Publ-8th Intern. Conf. Power Electron. and Variable Speed Drives*, No. 475 (2000), 392-397
- [13] Jintakosonwit, P., Akagi, H., Fujita, H. and Ogasawara, S. “Implementation and Performance of Automatic Gain Adjustment in a Shunt Active Filter for Harmonic Damping Throughout a Power Distribution System”. *IEEE Trans. Power Electron.*, 17, No. 3 (2002), 438-447.
- [14] Dixon, J.W., Venegas, G. and Morán, L.A. “A Series Active Power Filter Based on a Sinusoidal.
- [15] Detjen, D. and Park, M.H. “A New Hybrid Filter to Dampen Resonances and Compensate Harmonic Currents in Industrial Power Systems with Power Factor Correction Equipment.” *IEEE Trans. Power Electron.*, 16, No. 6 (2001), 821-827.

- [16] Dell'Aquila, A., Lecci, A. and Monopoli, V.G. "Fuzzy Controlled Active Filter Driven by an Innovative Current Reference for Cost Reduction." *IEEE Intern. Symposium Ind. Electron. Proc.*, No. 3
- [20] Hamadi, A., Al-Haddad, K., Rahmani, S. and Kanaan, H. "Comparison of Fuzzy Logic and Proportional Integral Controller of Voltage Source Active Filter Compensating Current Harmonics and Power Factor." *IEEE Intern. Conf. Ind. Techn.*, No. 2 (2004), 645-650.
- [21] Segulier, G. *Electronique De Puissance: Les Fonctions De Base et Leurs Principales Applications*. 7th ed., Paris: Dunod, 1999.[12] Choe, G.-H. and Park, M.-H. "A New Injection Method for an AC Harmonic Elimination by Active Power Filter". *IEEE Trans. Ind. Electron.*, 35, No. 1 (1988), 141-147.
- [22] Round, S. and Ingram, D.M.E. "An Evaluation of Techniques for Determining Active Filter Compensating Currents in Unbalanced Systems". *Europe Power Electron. Conf. Trondheim*, (1997), 4.767-4.772.

