

# Monitoring system for ATM machine theft Detection using Embedded design

A.Hima Bindu<sup>1</sup>, K.Narasappa<sup>2</sup>

<sup>1</sup>PG Scholar, Dept of ECE, Bheema Institute of Technology & Science, AP, India,

<sup>2</sup>Assistant Professor, Dept of ECE, Bheema Institute of Technology & Science, AP, India

**Abstract:** Automated Teller Machines (ATMs) security is the field of study that aims at solutions that provide multiple points of protection against physical and electronic theft from ATMs and protecting their installations. From anti-skimming defend systems to silent indicate systems, integrated ATM video surveillance cameras and ATM monitoring options, security specialists are ready to help the people get more out of the ATM security and ATM loss prevention systems. The implementation is achieved with the use of Machine-to-machine (M2M) communications technology. M2M communications is a topic that has recently attracted much attention It provides real-time monitoring and control without the need for human intervention. The idea of M2M platform suggests new system architecture for positioning and monitoring applications with wider coverage and higher communication efficiency. The aim of the proposed work is to implement a low cost stand-alone Embedded Web Server (EWS) based on ARM11 processor and Linux operating system using Raspberry Pi. It offers a robust networking solution with wide range of application areas over internet. The Web server can be run on an embedded system having limited resources to serve embedded web page to a web browser. The setup is proposed for ATM security, comprising of the modules namely, authentication of shutter lock, web enabled control, sensors and camera control. The project consists of the two sides. One is at the door side and another one is ATM side. We are using Raspberry Pi at the ATM side and 8051 microcontroller at the door side. Smoke and vibration sensors are used for protection purpose. Ethernet is used to send the sensor values are uploaded to the HTML web page. The alert messages are sending to the authorized person if vibration or smoke sensor detects. The person's mobile number was stored in the system at the initial stage.

**Keywords:** Raspberry Pi; M2M, Web Server; RF Communication, Embedded System.

## I. INTRODUCTION

The rapid growth in Automatic Teller machines (ATM) has made life easy for the day to day man, but it is not so for operators who manage it. ATMs are not owned by banks, rather they are outsourced to managed service providers (MSPs) from purchasing to maintaining the machines. Several factors like the maintenance, money filling, security and therefore the passive assets within the ATM rooms are responsible for keeping the ATM active [7]. Typically, an ATM site consists of anywhere between 8 to 12 passive assets which include two air

conditioners, two light collection boards, Associate in Nursing inverter/UPS, a security camera and a minimum of eight to twelve lightweight bulbs. Currently, since the security and passive assets in ATM rooms are managed manually, it ends up in larger physical interaction, that increase the time period and therefore shrinks the gross margin of ATM operators. These MSPs are duty-bound and every ATM site is up as costs of downtime are too high. With rising overheads ATM operators struggle to pass on the cost and so are looking for a reliable remote monitoring solution to revitalize ATM maintenance [3].

## II. MACHINE TO MACHINE COMMUNICATION

Machine to Machine (M2M) refers to technologies that allow both wireless and wired systems to communicate with other devices of the same type [2]. M2M may be a broad term because it does not pinpoint specific wireless or wired networking, information and engineering. M2M is considered an integral part of the Internet of Things (IoT) and brings many edges to industry and business in general as it has a wide range of applications like industrial automation, logistics, Smart Grid, sensible Cities, health, defense etc., largely for observation however conjointly for management functions.

M2M Architecture can include the case of industrial instrumentation -comprising a device (such as a sensor or meter) to capture an event (such as temperature, inventory level, etc.) that is relayed through a network (wireless, wired or hybrid) to associate degree application (software program) that interprets the captured event into substantive information (for example, things ought to be restocked). Such communication was originally accomplished by having a foreign network of machines to relay information back to a central hub for analysis, which might then be rerouted into a system like a personal computer [2]. The machine to machine communication in ATM has a great impact on building a powerful Security Based ATM theft monitoring system. However, there are many challenges in the design of the M2M communications network whereby this project deals with prevention of ATM theft from robbery. Sensor based network has been extensively used in monitoring and controlling purposes in ATM [3].

## III. FUNCTION DIAGRAM

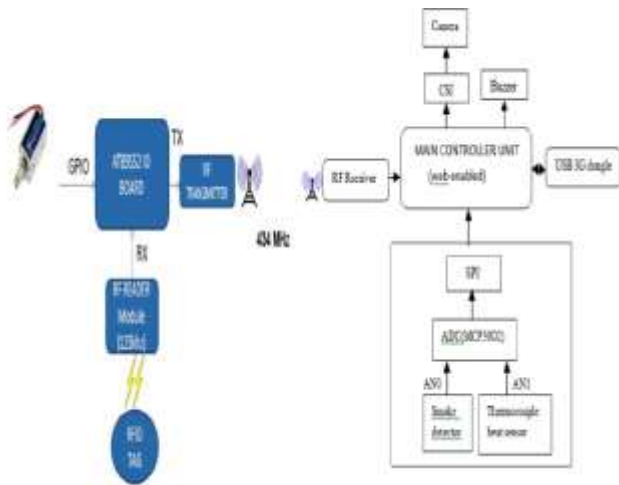

Fig. 1. Function Diagram.

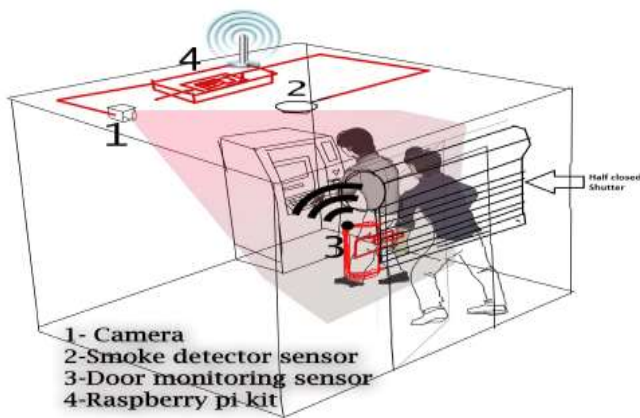

Fig. 2. Proposed Module.

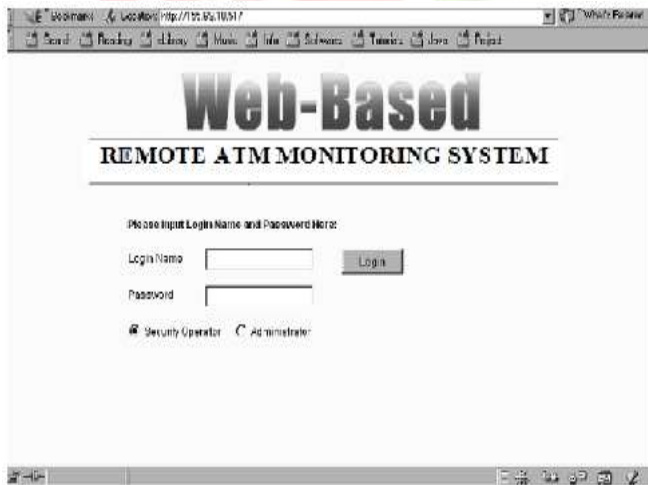

Fig. 3. Sample Login Page.

#### IV. SHUTTER LOCKING SYSTEM

RFID reader is placed on the outside of the shutter and is separate from the main controller unit. The controller receives serial data from the Reader and controls the shutter lock or unlock. When the card is brought near to the RFID module it reads the data in the card(as shown in Fig 4) and displays on the LCD. The data in the card is compared with the data in the

program memory and displays authorized or unauthorized message. The door opens for a licensed person, closes for associate unauthorized person. RFID tag is a contactless card, stated as a Proximity computer circuit Card (PICC). Tags could either be actively or passively high-powered. Active tags contain Associate in Nursing on-board power supply, like battery, whereas passive tags should be inductively high-powered via Associate in Nursing RF signal from the reader. the gap a reader could interrogate tags from is restricted by the tag's power. Consequently, active tags can also scan from a bigger distance than passive tags.

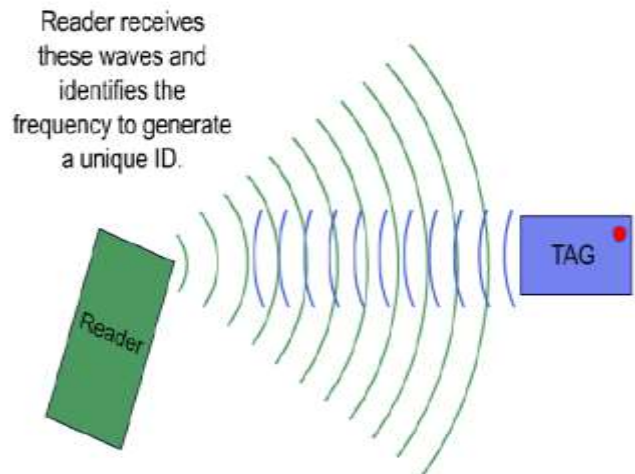

Fig. 4. RFID Reader Technologies[8].

#### A. RF Modules

The RFID module transmits a RF signal whenever it reads the information from the RFID card. The main control unit receives and prepares to require snap and transfer to server RF Modules square measure used wireless transfer information. This makes them most fitted for device applications, as in wherever it is required to regulate some machines or robots without getting in touch with them(may ensue to numerous reasons like safety, etc). currently relying upon the sort of application, the RF module is chosen (as shown in Fig5). For short range wireless control applications, an ASK RF Transmitter-Receiver Module of frequency 315 MHz or 433 MHz is most fitted.

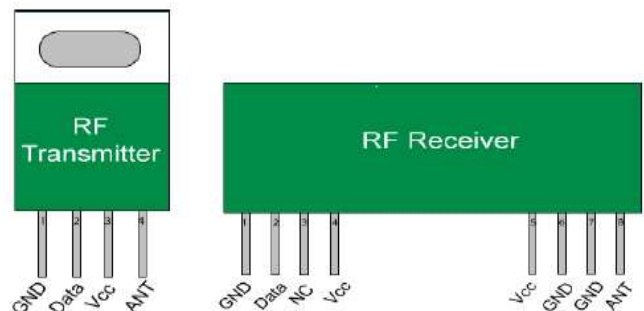

Fig. 5. RF Module devices[9].

#### V. RASPBERRY PI WEB SERVER

As ARM processor based web servers do not use computer directly, it helps a lot in cost reduction. The aim of the proposed work is to implement an Embedded Web Server (EWS) based

on ARM11 processor and Linux operating system using Raspberry Pi[6]. It gives a strong networking answer with wide range of application areas over internet. The web server runs on an embedded system having limited resources to serve embedded web page to a web browser. Different software can be used to implement the embedded web server, and these are mentioned below:

- Linux–operating system
- Apache–web server (http)software
- Mysql – database server
- PHP or Perl – programming languages

### A. Raspberry PI Camera

The Raspberry Pi camera board contains a five MegaPixel device, and connects via a ribbon cable to the CSI connective on the Raspberry Pi. The video and still image quality is better than a USB webcam of similar price. OpenCV is an open source computer vision library that can be used for many vision applications. In order for OpenCV to apply face recognition to the captured image python is used. At the command prompt when raspistill -o image.jpg is entered, the preview appears on the screen for a few seconds.

### B. Smoke Detector And Flame Detection

In case of gas attachment, heat sensors put within the machine raises associate in nursing alarm and intimates the operator on breaking, drilling, or cutting of the safe are carried out. A smoke detector is a device that senses smoke, usually as Associate in nursing indicator of fireside[1]. Most smoke detectors work either by optical detection (photoelectric) or by physical method (ionization), whereas others use each detection strategies to extend sensitivity to smoke. Sensitive alarms have been used for the detection method. Some smoke alarms use a carbonic acid gas detector or carbon monoxide gas detector to observe characteristic merchandise of combustion [4]. However, some gas sensors react on levels that are dangerous for humans however not typical for a fireplace; these are not usually sensitive or quick enough to be used as fire detectors. Alternative gas sensors are even ready to warn concerning particulate-free fires (e. g. sure alcohol fires).

### C. M2M Driven ATM Sites

The only solution to the above mentioned security problems are resorting to M2M technology. Banks can specialize in the safety of its client as they are of supreme interest, by implementing remote observance resolution across their ATM sites to resolve security problems. M2M put in ATMs are able to provide handiness, security, cut back field service visits, minimize system downtimes and minimize operative prices. Operators are directly alerted once a haul happens, and is able to resolve the threats in real time from a distant location. In case of physical attacks, vibration sensors put within the machine raises associate degree alarm and intimate the operator on breaking, drilling, or cutting of the safe area unit dispensed. Additionally anonymous closure of ATM shutter or any physical attacks on the patron is captured to boost alarm to the general public, and additionally to the closest police headquarters. Apart from the protection, M2M assists the operators to beat different bottlenecks mounting on them like

energy management, fault management, rising operative prices, and news. Optimized utilization of infrastructure, continuous network period of time, and reduced operative prices maximizes revenues for ATM operators are also provided. Smart ATMs add location intelligence and enhances observance visually by desegregation Google map. It allows integrating Google Maps and placing the sites on the maps in step with the geographic distribution. The site status of a site can be viewed during a popup by clicking on the positioning balloons on the Google Map [7]. Furthermore the site location on this popup redirects to site exposure page containing sensing element standing, power supply, power consumption pattern, etc., The operators/IT directors get a comprehensive understanding of however distributed the site/device extremely is[7]. With this graphical read alert notifications and alarm count of web sites in multiple geographical locations across the world can be viewed as shown in Fig.6. Thus, it empowers IT directors to pinpoint problems and resolve the problems in numerous web sites across the world with a additional visual bit.



Fig. 6. Google map integrate ATM site Manager [10]

The hosted website on raspberry pi can be accessed by the client[6]. The client has to type the WAN IP address of website in address bar of any web browser. Client can see the webpage as displayed as shown in Fig 7.

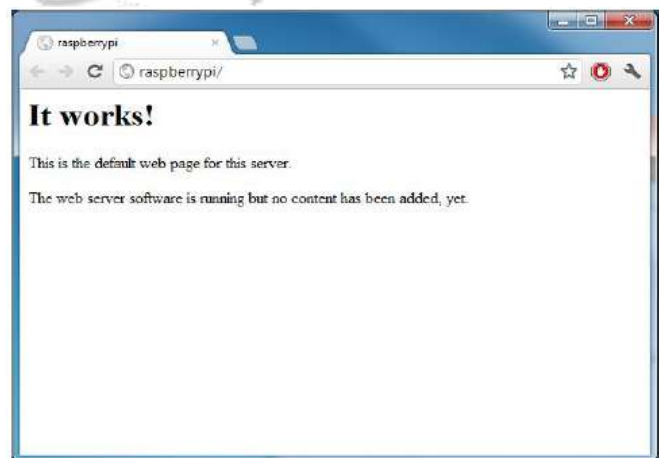

Fig. 7. Sample webpage.

## VI. RESULT

Security and passive assets in ATM rooms are managed manually and it ends up in larger physical interaction, that

increase the time period and therefore shrinks the gross margin of ATM operators. These MSPs are duty-bound to create certain that every ATM site is up as costs of downtime are too high. With rising overheads ATM operators struggle to pass on the cost and so are looking for a reliable remote monitoring solution to revitalize ATM maintenance. The M2M-based ATM monitoring system has advantages in many aspects. Firstly, the integration of M2M platform has changed the traditional network structure of the monitoring system. By implementing the whole module in real time one can make an ATM better safe from intruder and thefts. The solution is also cost effective when compared to the existing manual solutions.



**Fig8. Detection by Smoke Sensor**



**Fig9. Theft Detection at door side .**

## VII. CONCLUSION

The proposed system ensures to develop advanced ATM anti theft system. In this project an advance and cost effective approach for ATM security has been proposed. It can be installed in the ATM at some hidden place so that it cannot be approached by thieves. Proposed system is distinctive in many ways from existing ATM intrusion and theft control systems; already used systems are either very expensive or ineffective from distance. It is reliable, inexpensive and appropriate design.

## VIII. REFERENCES

- [1]. Kannamma, M. Barathi, B. Chanthini, and D.Manivannan. "Controlling and monitoring process in industrial automation using Zigbee." Advances in Computing, Communications and Informatics (ICACCI), 2013 International Conference on. IEEE, 2013.
- [2]. Kim, Jaewoo, Jaiyong Lee, and J. Yun. "M2M serviceplatforms: survey, issues, and enabling technologies." (2013): 1-16.
- [3].Dujak,Mico,etal. "Machine-to-machine communications key enabler in smart metering systems." Information & Communication Technology Electronics & Microelectronics (MIPRO), 2013 36th International Convention on. IEEE, 2013.
- [4]. Kannan, P, and Ms P. Meenakshi Vidya. "Design and Implementation of Security Based ATM theft Monitoring system."
- [5]. Ajaykumar M (2013). "Anti-Theft ATM Machine Using Vibration Detection Sensor" International Journal of Advanced Research in Computer Science and Software Engineering, pp: 23-28.
- [6]. Liu, Yakun, and Xiaodong Cheng. "Design and implementation of embedded Web server based on armand Linux." Industrial Mechatronics and Automation (ICIMA), 2010 2nd International Conference on. Vol. 2.IEEE, 2010.
- [7].<http://blogs.webnms.com/m2m/2014/08/28/bid-adieu-toguards-welcome-atm-site-manager/>
- [8].<http://www.engineersgarage.com/rfid-radio-frequency-identification-and-detection>
- [9]. <http://www.engineersgarage.com/electroniccomponents/rf-module-transmitter-receiver>
- [10]<http://blogs.webnms.com/m2m/2013/05/31/webnmsintegrates-google-maps-in-m2m-solutions/>