

An Advanced Internet of Things Based Security Alert System for Smart Home

¹Dr.R.Naveen, ²S.A.Sivakumar, ³P.Amala, ⁴S.Baskar, ⁵R.Dharun, ⁶K.Harinandhan

¹Associate Professor & Head, ^{2,3}Assistant professor, ^{4,5,6}UG Scholar

^{1,2,3,4,5,6}Department of Electronics and Communication Engineering

^{1,2,3,4,5,6}Info Institute of Engineering, Coimbatore, Tamilnadu, India

Abstract : In this paper we implement a smart security system using a camera via ip with an ultrasonic sensor module to enhance the intruder alert in absence of our surrounding. The ultrasonic sensor has a transmitter and a receiver that measures the distance of the intruder. The ultrasonic sensor is set in a rotating motor to cover a wide range. The Ultrasonic sensor emits ultrasonic signals into an open environment. A rotating motor is used to allow the sensor to cover whole 360 degrees. If the signal ever hits any objects, it will be reflected back to the receiver of the sensor. The microcontroller unit (MCU) will periodically check for the receiver signal of the ultrasonic transmitter. If the receiver output is high, the MCU will perform distance calculations of the object from the sensor and sends a text message to mobile via GSM module. The text message displays the alert for the user to know the presence of intruder. The user can then view the video stream via ip camera to know who the intruder is, if it is a known person the user can give a command through a app to unlock the door and let the person inside the house.

Index Terms – Internet of things, Smart home, Microcontroller, ultrasonic sensor

I. INTRODUCTION

Ultra sonic based technology is used to improve the home safety based on IOT. Security is an integral part in home, banks, shops, industries and so on. In traditional method it is based on opening of doors and windows by humans. A manual power is must in traditionally used method. Our ultrasonic sensor technology detects all un -authorized persons. An ultrasonic sensor can measure the distance to an obstacle or a target or persons within its range. The arduino atmega microcontroller is used to interface with the ultrasonic sensor. In Atmega16A microcontroller there are three timers and the serial rs232 USART protocol. The timers are used to assign various functions based on scheduling and to generate clocks and frequencies on respective periods to drive the motor. Also, use the motor drivers and it acts as current amplifiers since they take a low current control signal and provide a higher current signal..ip web camera app is used to constantly monitor and maintain the activities in our home. The blynk app is used for regulating the control over the home from very distant areas.

II. LITERATURE SURVEY

2.1 IOT Based Smart Home System Technologies

Using IoT, the objects can be sensed and can be operated under our surveillance. It results improved efficiency, accuracy and economic benefit in addition to reduced human intervention. IoT systems are not only used to find or sense the thing, it is also used to performing the actions. It is not only used for monitoring, it can also be used to sense the things. Other applications that the Internet of Things can provide enabling extended home security features and home automation. This paper relates smart home or home automation which induce technology for home atmosphere which is usage to provide ease and protection to its occupants.

2.2 IOT Based Smart Home

A IoT based smart home gives so much comfort to home owners. It gives more comfort and security. It is very helpful to monitoring the home when we are not in the home. It is also used to operate the doors from outside of the house. This project details the installation and configuring the sensors in a person's home. If our neighbor reached our home during our office time, we can open the door from the office to enter that person into our home. The IoT gateway will allow the online wireless sensor monitoring and notification system without the need of computer. Necessary security implementations are done to notify the owner on event occurrence.

2.3 Smart Home Automation using IOT

Smart Home has many advantages. It is very useful to save human power, time and it is efficient. The main objective of smart home is to help old and handicapped people. In Smart Home, we can access the electronic devices. We can use a server to give instruction to devices. We can control the home electronic equipments with just a click in smart home.

2.4 Smart Home Control System by Internet of Things Based on WIFI Module

Internet of Things is the latest and emerging technology, which will enable physical objects used in day to day life to connect to the internet and exchange data. In this paper, Smart home control system using IoT is a system that uses computers or mobile devices to control basic home functions and features automatically through a server which interfaces the electronic devices and mobile via internet. This system uses PIC controller interfaced with ESP 8266 using AT COMMANDS and sensors that enables wireless communication and remote control of various electrical appliances with in their home. This system also provides security systems with low cost RFID technology.

III. PROPOSED METHOD

Here the proposed system is a home automation and home monitoring system. Using Iot we create a platform to interface the Mobile and Electronic devices. The Intel Galileo development board, with built in Wi-Fi card port to which the card is inserted, acts as web server. Automation System can be accessed from the web browser of any local PC in the same LAN using server IP, or remote for many PC or mobile handheld device connected to the internet with appropriate web browser through server real IP (internet IP). Wi-Fi technology is selected to be the network infrastructure that connects server and the sensors. Wi-Fi is chosen to improve system security (by using secure Wi-Fi connection), and to increase system mobility and scalability

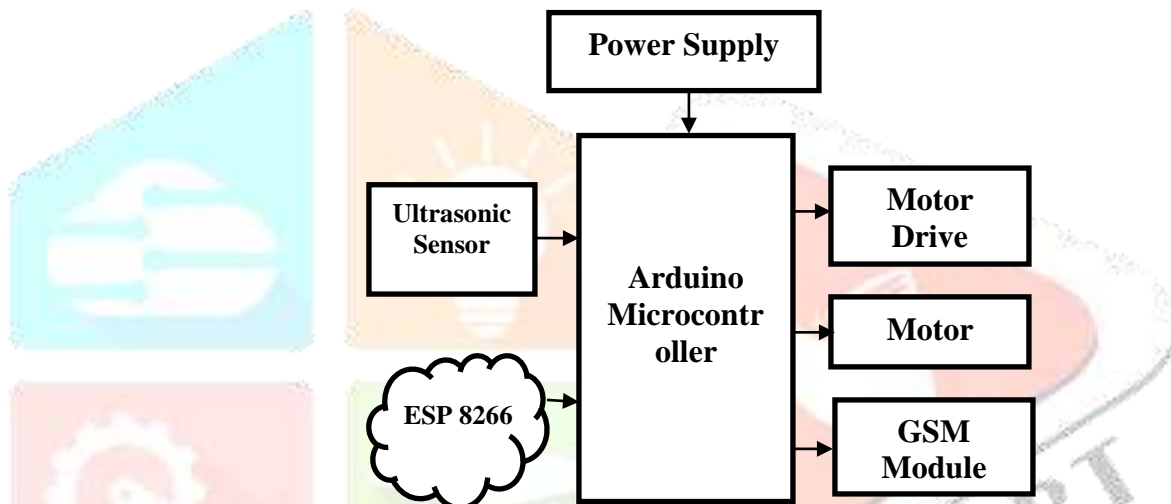

Fig.3.1 proposed block diagram

IV. MATERIALS & METHODS

4.1 Arduino UNO board

In this chapter, we will learn about the different components on the Arduino board. We will study the Arduino UNO board because it is the most popular board in the Arduino board family. In addition, it is the best board to get started with electronics and coding. Some boards look a bit different from the one given below, but most Arduinos have majority of these components in common.

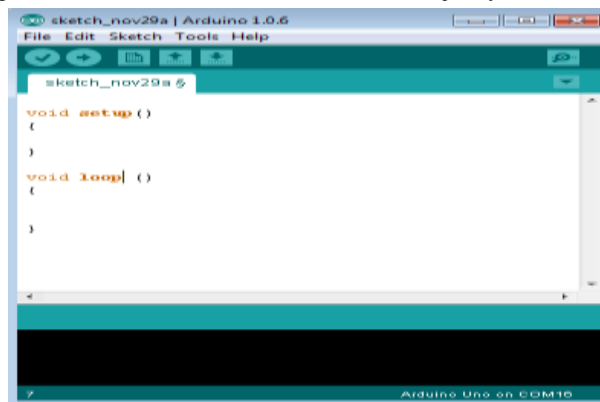

Fig.4.1 Aduino board software

Arduino programs can be divided in three main parts: Structure, Values (variables and constants), and Functions. In this tutorial, we will learn about the Arduino software program, step by step, and how we can write the program without any syntax or compilation error.

Let us start with the Structure. Software structure consist of two main functions –

Setup() function
Loop() function

```
Void setup () {  
}
```

PURPOSE – The setup() function is called when a sketch starts. Use it to initialize the variables, pin modes, start using libraries, etc. The setup function will only run once, after each power up or reset of the Arduino board.

INPUT – -

OUTPUT – -

RETURN – -

```
Void Loop () {
```

```
}
```

PURPOSE – After creating a setup() function, which initializes and sets the initial values, the loop() function does precisely what its name suggests, and loops consecutively, allowing your program to change and respond. Use it to actively control the Arduino board.

INPUT – -

OUTPUT – -

RETURN – -

Decision making structures require that the programmer specify one or more conditions to be evaluated or tested by the program. It should be along with a statement or statements to be executed if the condition is determined to be true, and optionally, other statements to be executed if the condition is determined to be false.

Following is the general form of a typical decision making structure found in most of the programming languages –

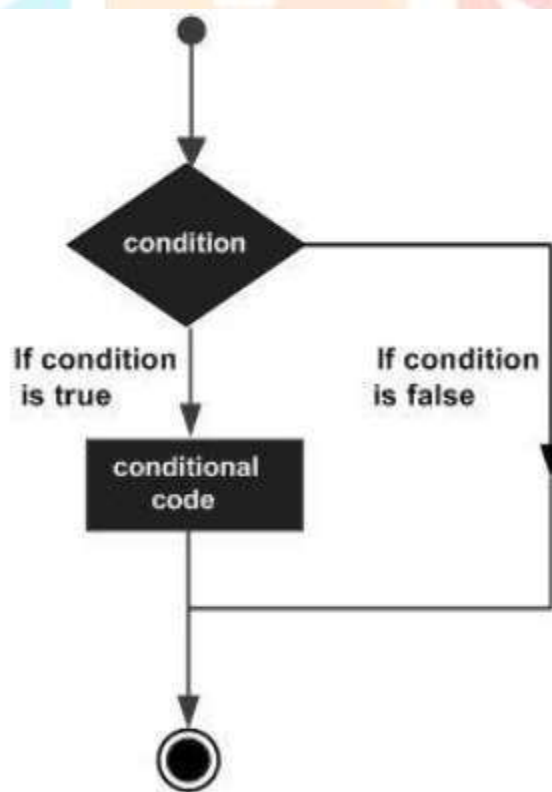

Fig.4.2 Loop structure

Control Statements are elements in Source Code that control the flow of program execution.

4.2 Arduino Microcontroller

Arduino is a single-board microcontroller meant to make the application more accessible which are interactive objects and its surroundings. The hardware features with an open-source hardware board designed around an 8-bit Atmel AVR microcontroller or a 32-bit Atmel ARM. Current models consists a USB interface, 6 analog input pins and 14 digital I/O pins that allows the user to attach various extension boards.

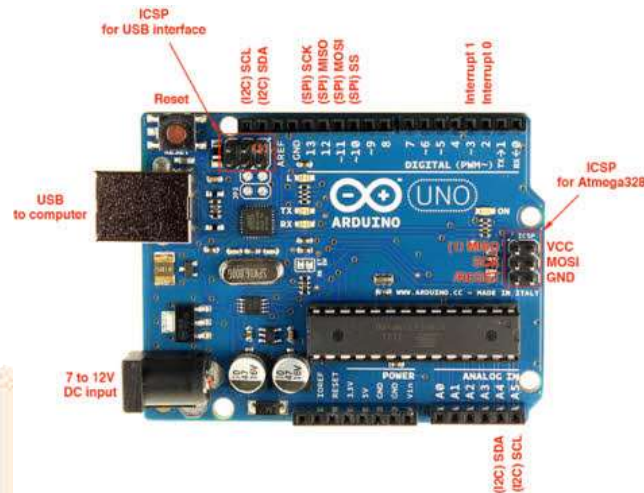

Fig.4.3 structure of Arduino Microcontroller

The Arduino Uno board is a microcontroller based on the ATmega328. It has 14 digital input/output pins in which 6 can be used as PWM outputs, a 16 MHz ceramic resonator, an ICSP header, a USB connection, a power jack and a reset button. This contains all the required support needed for microcontroller. In order to get started, they are simply connected to a computer with a USB cable or with a AC-to-DC adapter or battery. Arduino Uno Board varies from all other boards and they will not use the FTDI USB-to-serial driver chip in them. It is featured by the Atmega16U2 (Atmega8U2 up to version R2) programmed as a USB-to-serial converter.

4.3 DC Motor

The direct current motor is represented by the circle in the center, on which is mounted the brushes, where we connect the external terminals, from where supply voltage is given. On the mechanical terminal we have a shaft coming out of the Motor, and connected to the armature, and the armature-shaft is coupled to the mechanical load. On the supply terminals we represent the armature resistance R_a in series. Now, let the input voltage E , is applied across the brushes. Electric current which flows through the rotor armature via brushes, in presence of the magnetic field, produces a torque T_g . Due to this torque T_g the dc motor armature rotates. As the armature conductors are carrying currents and the armature rotates inside the stator magnetic field, it also produces an emf E_b in the manner very similar to that of a generator. The generated E_b is directed opposite to the supplied voltage and is known as the back Emf, as it counters the forward voltage



Fig.4.4 structure of DC Motor

4.4 ESP 8266(Wi-Fi Module)

ESP8266 offers a complete and self-contained Wi-Fi networking solution, allowing it to either host the application or to offload all Wi-Fi networking functions from another application processor.

When ESP8266 hosts the application, and when it is the only application processor in the device, it is able to boot up directly from an external flash. It has integrated cache to improve the performance of the system in such applications, and to minimize the memory requirements.



Fig.4.5 wi-Fi module

Alternately, serving as a Wi-Fi adapter, wireless internet access can be added to any microcontroller-based design with simple connectivity through UART interface or the CPU AHB bridge interface. ESP8266 on-board processing and storage capabilities allow it to be integrated with the sensors and other application specific devices through its GPIOs with minimal development up-front and minimal loading during runtime. With its high degree of on-chip integration, which includes the antenna switch balun, power management converters, it requires minimal external circuitry, and the entire solution, including front-end module, is designed to occupy minimal PCB area. Sophisticated system-level features include fast sleep/wake context switching for energy-efficient VoIP, adaptive radio biasing for low-power operation, advance signal processing, and spur cancellation and radio co-existence features for common cellular, Bluetooth, DDR, LVDS, LCD interference mitigation.

4.5 GSM

GSM (Global System for Mobile communication) is a digital mobile telephony system that is widely used in Europe and other parts of the world. GSM uses a variation of time division multiple access (TDMA) and is the most widely used of the three digital wireless telephony technologies (TDMA, GSM, and CDMA). GSM digitizes and compresses data, then sends it down a channel with two other streams of user data, each in its own time slot. It operates at either the 900 MHz or 1800 MHz frequency band.



Fig.4.6 GSM module

Mobile services based on GSM technology were first launched in Finland in 1991. Today, more than 690 mobile networks provide GSM services across 213 countries and GSM represents 82.4% of all global mobile connections. According to GSM World, there are now more than 2 billion GSM mobile phone users worldwide. GSM World references China as "the largest single GSM market, with more than 370 million users, followed by Russia with 145 million, India with 83 million and the USA with 78 million users.

4.6 Motor Driver:

L293D is a typical Motor driver or Motor Driver IC which allows DC motor to drive on either direction. L293D is a 16-pin IC which can control a set of two DC motors simultaneously in any direction. It means that you can control two DC motor with a single L293D IC. Dual H-bridge Motor Driver integrated circuit(IC).

The L293D can drive small and quiet big motors as well, check the Voltage Specification at the end of this page for more info.

You can Buy L293D IC in any electronic shop very easily and it costs around 70 Rupees (INR) or around 1 \$ Dollar (approx Cost) or even lesser cost. You can find the necessary pin diagram, working, a circuit diagram, Logic description and Project as you read through.

Concept It works on the concept of H-bridge. H-bridge is a circuit which allows the voltage to be flown in either direction. As you know voltage need to change its direction for being able to rotate the motor in clockwise or anticlockwise direction, Hence H-bridge IC are ideal for driving a DC motor.

In a single L293D chip there two h-Bridge circuit inside the IC which can rotate two dc motor independently. Due its size it is very much used in robotic application for controlling DC motors. Given below is the pin diagram of a L293D motor controller.

There are two Enable pins on L293D. Pin 1 and pin 9, for being able to drive the motor, the pin 1 and 9 need to be high. For driving the motor with left H-bridge you need to enable pin 1 to high. And for right H-Bridge you need to make the pin 9 to high. If anyone of the either pin1 or pin9 goes low then the motor in the corresponding section will suspend working. It's like a switch.

TIP: you can simply connect the pin16 VCC (5v) to pin 1 and pin 9 to make them high.

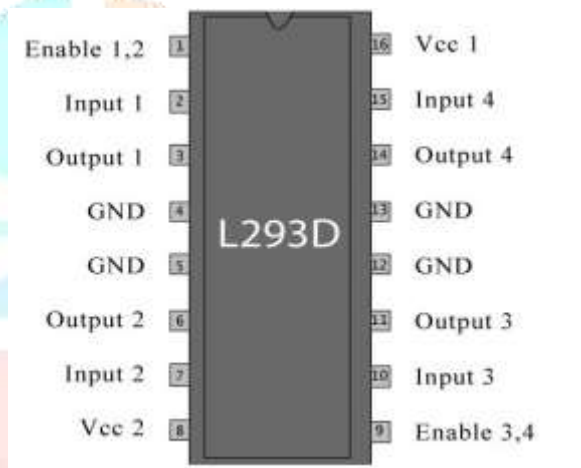

Fig.4.7 Motor driver

4.7 Ultrasonic Sensor

It transmit an ultrasonic wave in uni direction. When it encounters an target it return back to the receiver. It operates at an input voltage of 5V DC. The required frequency is about 40HZ. The range of the sensor is from 2cm to 4cm.



Fig.4.8 Ultrasonic Sensor

V. HARDWARE RESULT

The hardware result of the proposed system is shown in fig. 5.1



Fig.5.1 Hardware setup

VI. CONCLUSION

In this paper, the home automation using Internet of Things has been experimentally proven to work satisfactorily by connecting simple appliances to it and the appliances were successfully controlled remotely through internet. The designed system not only monitors the sensor data, like temperature, gas, light, motion sensors, but also actuates a process according to the requirement, for example switching on the light when it gets dark. It also stores the sensor parameters in the cloud (Gmail) in a timely manner. This will help the user to analyze the condition of various parameters in the home anytime anywhere.

VII. ACKNOWLEDGMENT

Our sincere thanks to the management of Info institute of engineering for providing the research lab for our work.

REFERENCES

- [1]. G. Kortuem, F. Kawsar, D. Fitton, and V. Sundramoorthy, "Smart objects as building blocks for the internet of things," *Internet Computing*, IEEE, vol. 14, pp. 44-51, 2010.
- [2]. R. J. C. Nunes and J. C. M. Delgado, "An Internet application for home automation," in *10th Mediterranean Electrotechnical Conference (MELECON 2000)*, Lemosos, 2000, pp. 298-301.
- [3]. R. Piyare and M. Tazil, "Bluetooth Based Home Automation System Using Cell phone," in *IEEE 15th International Symposium on Consumer Electronics*, Singapore 2011, pp. 192 - 195.
- [4]. S. Anwaarullah and S. V. Altaf, "RTOS based Home Automation System using Android," *International Journal of Advanced Trends in Computer Science and Engineering*, vol. 2, pp. 480- 484, January 2013.
- [5]. Interactive Applications for Smart Living," in *2nd International Conference on Innovations in Bioinspired Computing and Applications (IBICA 2011)*, pp. 309-312.
- [6]. D. Javale, M. Mohsin, S. Nandanwar, and M. Shingate, "Home Automation and Security System Using Android ADK," *International Journal of Electronics Communication and Computer Technology (IJECCT)*, vol. 3, pp. 382-385, March 2013.
- [7]. J. Potts and S. Sukittanon, "Exploiting Bluetooth on Android mobile devices for home security applications," in *Southeastcon, 2012 Proceedings of IEEE Orlando, FL 2012*.

- [8]. R. A. Ramlee, M. H. Leong, R. S. S. Singh, M. M. Ismail, M. A. Othman, H. A. Sulaiman, et al., "Bluetooth Remote Home Automation System Using Android Application," The International Journal of Engineering And Science, vol. 2, pp. 149-153, 11, January 2013.
- [9]. M. Yan and H. Shi, "Smart Living Using Bluetooth Based Android Smartphone," International Journal of Wireless & Mobile Networks, vol. 5, pp. 65-72, February 2013.
- [10]. N. Swamy, O. Kuljaca, and F. L. Lewis, "Internet-based educational control systems lab using Net Meeting" IEEE Transactions on Education, vol. 45, pp. 145-151, 07 August 2002.

