

DESIGN AND ANALYSIS OF UNITY POWER FACTOR CONVERTER USING FPGA CONTROLLER

¹Mr. V. Surendar, ²Miss. P. Soniya,
¹Assistant Professor, ²PG Scholar,
¹Department of Electrical and Electronics Engineering,
¹Kongu Engineering College, Perundurai, India.

Abstract: In Power Electronics Application, the uncontrolled rectifiers are commonly used for AC-DC conversion which is located in the front end of industrial applications. The non-linear load naturally generates harmonic currents which cause major problem and affects the power quality at mains. Thus the high harmonic content of the power lines is resulting low power factor and voltage distortion. In addition several applications demand the capability of power regeneration to the power supply. These problems are alleviating by using Pulse Width Modulated (PWM) rectifiers which means the reduced THD can be achieved and power regeneration is possible. The converter switches are replaced by Insulated Gate Bipolar Transistor (IGBT) at its front end instead of diodes which is named as Active Front End (AFE) rectifier. The Active Front End converter is swelling solution for harmonic content elimination at the input line. This paper presents the field of Active Front End rectifier with reduced input current harmonics and it improves power factor, which increases the system stability and performance. The analysis and implementation of software is accomplished by MATLAB Simulink and its hardware is developed in hardware as prototype model.

Index Terms - PWM, IGBT, AFE, Harmonics, Regeneration and Power Factor.

I. INTRODUCTION

The AC-DC conversion is wildly used in industrial applications. such as power supply for microelectronics, household electric appliances, electronic ballast, battery charging system, dc motor drives, and power conversion [1]. These types of converters are classified by the topologies of working with low switching frequency and high switching frequency. Normally the uncontrolled converters are mainly used in power conversion [2]. The main disadvantages of those converters are generation of harmonic and reactive power. One of the method to reduce harmonics in the line side called power factor correction method [3-5]. In these type of converters power switches is having power circuit of the rectifiers, to change the waveform of input current, reducing the distortion and improves the power factor. Thus the power factor correction converter is called Active Front End Rectifier [6] otherwise called PWM regenerative rectifiers. This PWM Regenerative rectifier is preferred choice for providing a DC voltage source for DC loads, voltage fed drives, due to its capacity of input power factor regulation, line current harmonic mitigation, DC voltage control and bi-directional power flow [7-9]. This technique is most promising thanks to advance in power semiconductor devices and digital controller, which allow fast operation and cost reduction. The normal rectifier cannot regenerative. But this Active Front End converter must be able to deliver energy back to the power supply. The low THD increases the power factor of the system as unity and it also improves the system stability and performance. The active frond rectifier is located at the front end of the power system and which is converted the AC power to DC power shown in fig 1.1.

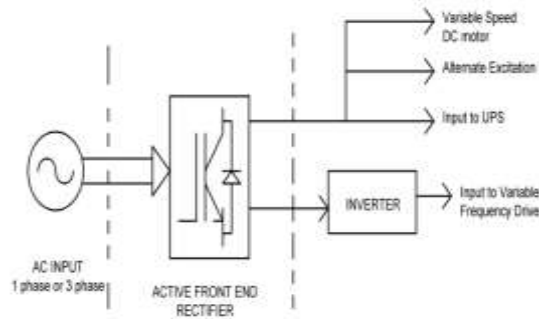

Fig.1.1. Basic diagram of Active Front End Rectifier

II. ACTIVE FRONT END RECTIFIER

The Active front end rectifier is the one in which the front end stage of the inverter for a motor application is replaced by controlled AC/DC converter instead of diode rectifier. Such a rectifier provides better power factor and offers stable power quality. The term Active Front End Rectifier refers to the power converter system consisting of the Line side converter with active switches such as IGBTs. This converter, during regeneration it can also be operated as an inverter, feeding power back to the line. Active Front End Rectifier is popularly referred to as a PWM rectifier. This is due to fact that, with active switches, the rectifier can be switched using suitable pulse width modulation technique.

III. OPERATION OF AFE RECTIFIER

The basic operation principle of Active Front End Rectifier is that it maintains the DC-link voltage at a desired reference value with the use of feedback control loop as shown in fig 3.1. The circuit behaves like a Boost converter when it operates in rectifier mode and it works as a Buck converter during inverter operation. The control of the DC-link voltage requires a feedback control loop. The DC voltage V_o is compared with a reference $V_o \text{ ref}$, and the error signal “e” obtained is used to produce a template waveform. The template should be a sinusoidal waveform with the same frequency of the input supply. The dc voltage (V_{dc}) can be regulated by the reference value of V_{dc} . Dc link voltage can be regulated using following equation (1).

$$V_d > 1.634 V_{L-L} \tag{1}$$

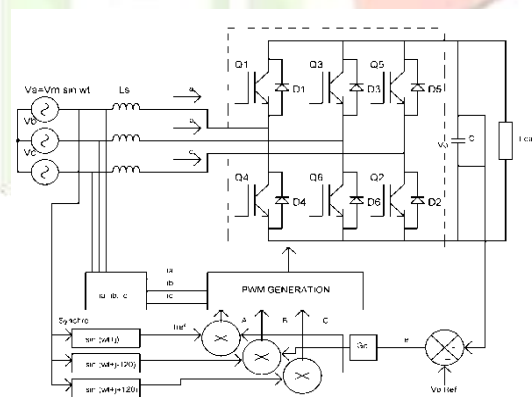

Fig 3.1. Closed loop control diagram of Active Front End Rectifier

3.1 SWITCHING SEQUENCE OF AFE RECTIFIER

The sequence of conduction changes after every 60° as follows: 561, 612, 123, 234, 345, 456 and the sequence continues again with 561. This sequence is with respect to the input voltage waveforms provided separately in which at 0° , the R^+ waveform crosses the zero point to positive side. The fig 3.1.1 explains the switching sequence of input line side. Since AFE rectifier has IGBT switches in parallel with the uncontrolled diodes, the conduction is for 180° (i.e.) the positive side diodes conduct when their anodes see positive phase voltages (i.e.) diode D_1 has the ability to conduct for 180° when the R phase voltage is positive and similarly D_3 with Y phase voltage and D_5 with B phase voltage becoming positive; similarly the negative side diodes D_2, D_4 and D_6 conduct when their cathodes see negative phase voltages (i.e.) D_2 when B phase becomes negative, D_4 when R phase becomes negative and D_6 when Y phase becomes negative.

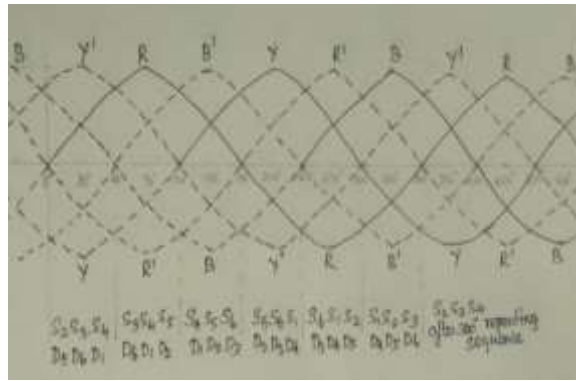

Fig. 3.1.1. Switching sequence of Active Front End Rectifier

3.2 IMPLEMENTATION OF PWM METHOD

The Output Voltage of the Active front End Rectifier can be modified or controlled by controlling the gate current of the IGBTs. This method is popularly called as Pulse Width Modulation (PWM) method. There are various techniques to vary the rectifier output. The commonly used techniques are, single pulse width modulation control, there is only one pulse per half - cycle and the width of the pulse is varied to control output voltage. The amplitude modulation index or simply modulation index is derived as $M=A_r/A_c$.

3.3 DESIGN PARAMETERS OF AFE RECTIFIER

These two relations are employed for the design of the current controlled AFER. These relate the values of DC-link capacitor, DC-link voltage, RMS voltage supply [3], input resistance and inductance, and power factor, with the RMS value of the input current.

$$K_p \leq \frac{C V_o}{3 I_s L_s} \quad (2)$$

$$K_i \leq \frac{K_p V_x - 2 R K_p I_s}{L_s I_s} \quad (3)$$

The source inductance is calculated by using this equation, $V = 2L \frac{di}{dt}$ (4)

IV. SIMULATION AND HARDWARE RESULTS DISSCUSSION

4.1 Simulation diagram of Active Front End Rectifier

The simulation diagram is plotted by using MATLAB Simulink and it is stimulated to get the simulation results. Here the control block is controlled the IGBT based converter by closed feedback control. The simulation results can be viewed by connecting the scope component in the MATLAB/SIMULINK. The simulation diagram of the closed loop control of Active Front End Rectifier is shown in fig 4.1.1.

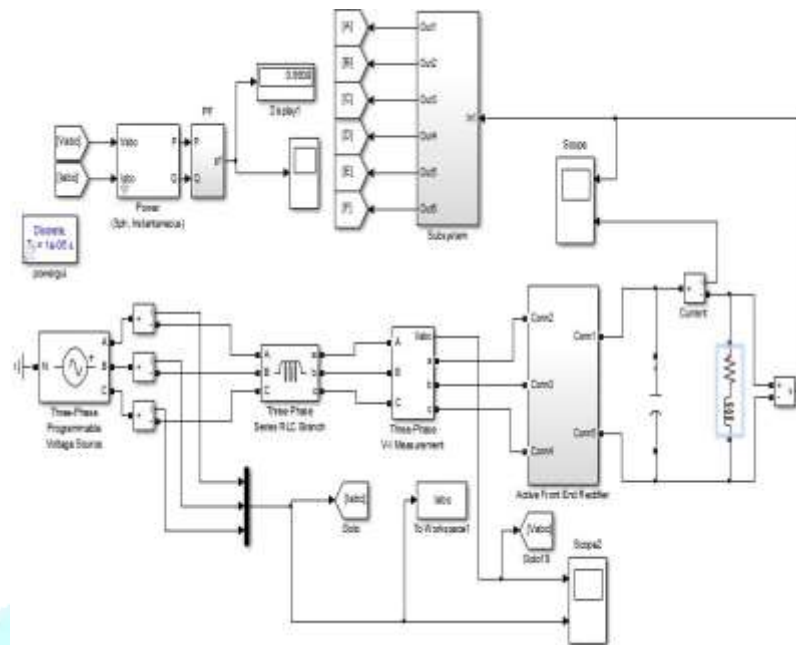

Fig.4.1.1. Simulation diagram of Active Front End Rectifier.

4.2 Simulation Output and FFT Analysis of Active Front End Rectifier.

The controller is operating the IGBT's at different switching frequencies THD value is reduced. Hence, AFE Rectifier is effective in eliminating DC link voltage pulsations occurring due to the unbalance while operating in unity power factor.

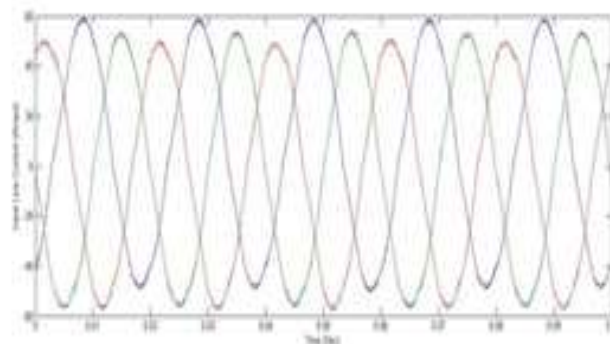

Fig.4.2.1. Input current at the line side

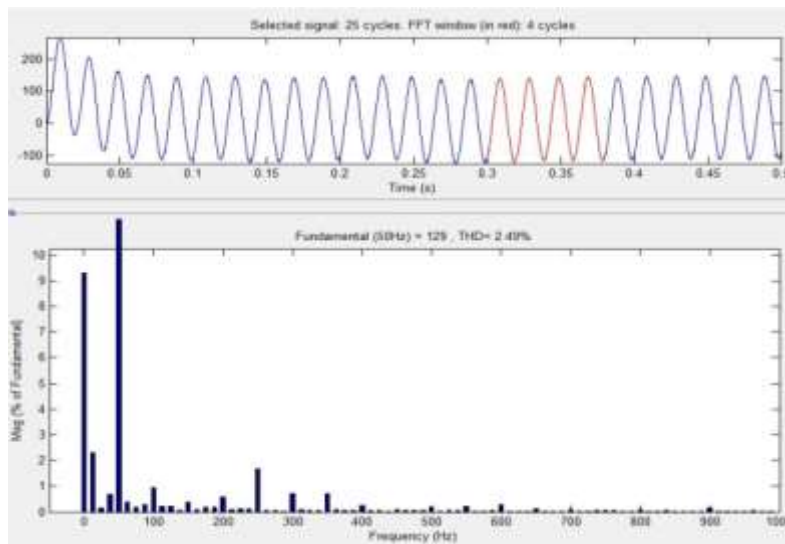

Fig. 4.2.2. THD analysis of AFE Rectifier with load 10Ω, 5mH.

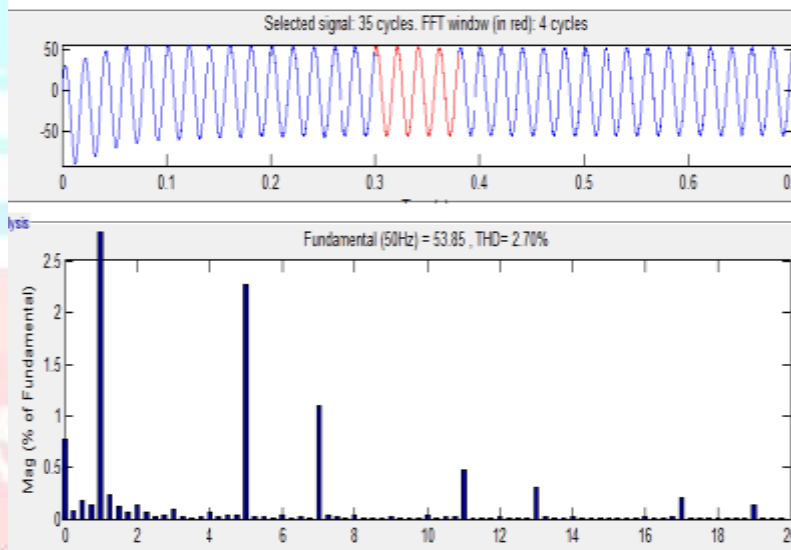

Fig. 4.2.3. THD analysis of AFE Rectifier with load 20Ω, 5mH.

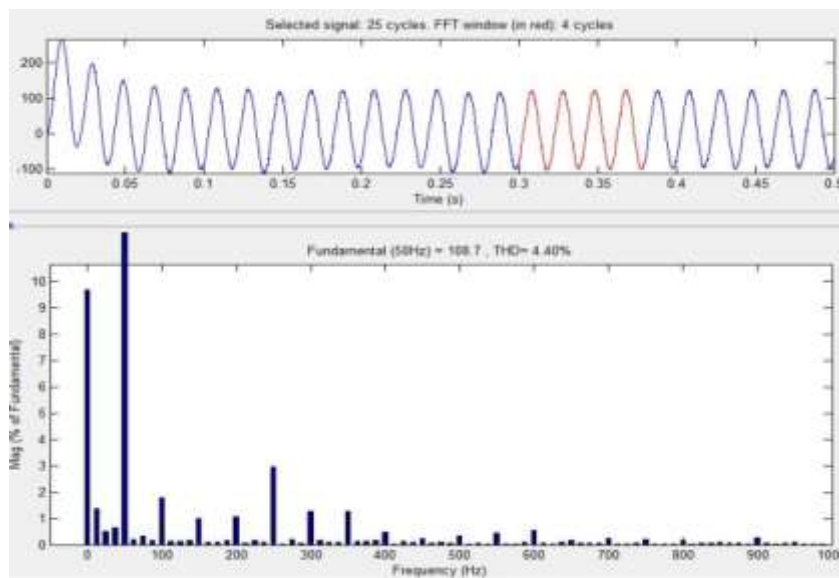

Fig. 4.2.4. THD analysis of AFE Rectifier with load 30Ω , 5mH .

4.3 Measurement of THD and Power Factor with $V_{dc} = 700\text{ V}$ at switching Frequency 10 kHz .

TABLE: 4.3.1. THD and Power factor Values With $f_s = 10\text{ kHz}$

S.NO	LOAD (RL)	SOURCE INDUCTANCE (mH)	CURRENT THD (%)	POWER FACTOR
1	$10\Omega, 5\text{mH}$	20	2.49	0.9867
2	$20\Omega, 5\text{mH}$	20	2.70	0.9924
3	$30\Omega, 5\text{mH}$	20	4.40	0.9927

4.4 HARDWARE SETUP AND RESULTS

The hardware setup is developed as prototype which is shown in fig 4.4.1. The FPGA controller is controlled the PWM pulses of IGBT. The input voltage of the prototype is 70V AC but it is boosted as output with its amplitude is 180V DC . The output results are viewed by using Digital Storage Oscilloscope (DSO).



Fig. 4.4.1. Hardware prototype of Active Front End Rectifier

The fig.4.4.2 and fig. 4.4.3 are the input current waveforms which are perceived by DSO. The fig 4.4.2 is the current but its shape is non-sinusoidal which flow through the system without control methods. In this fig 4.4.3, the voltage and current are in same phase sequence which means the angle between the voltage and current is nearly zero. It shows the system which is maintained as unity power factor.

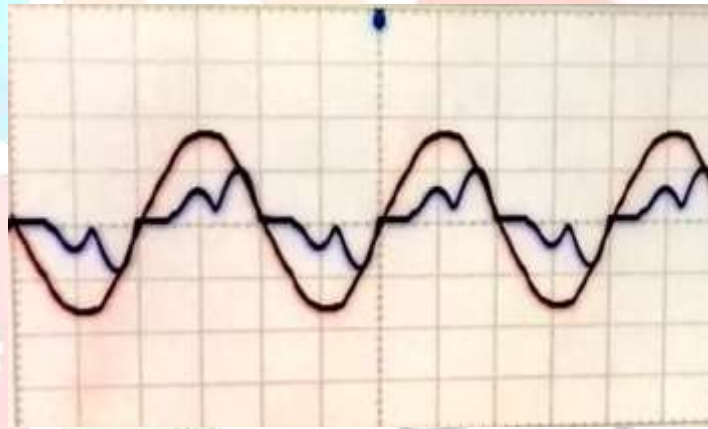

Fig. 4.4.2. Non sinusoidal waveform of input voltage and current.

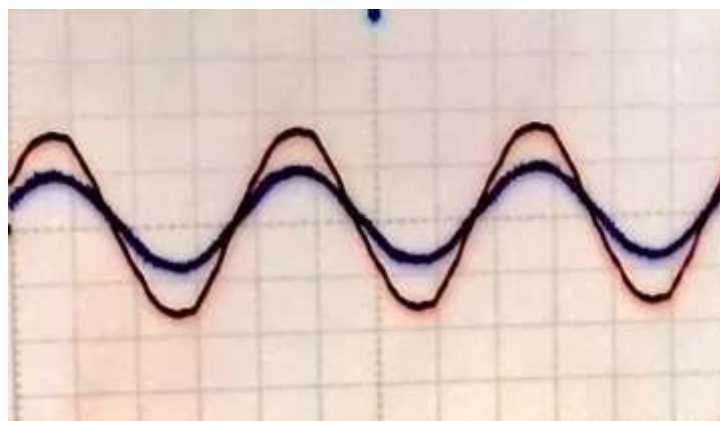

Fig. 4.4.3. Sinusoidal waveform of input voltage current.

V. CONCLUSION

This paper has reviewed the most important control schemes used to obtain AC-DC conversion with bidirectional power flow and very high power factor. In this type of PWM regenerative rectifiers are today standard solution in modern AC locomotives. This model gives the boosted constant DC output voltage from three phase input supply. From the Simulink and hardware results, the input power factor is unity and the line current wave is pure sinusoidal. By using FFT analysis, the THD is obtained as 2.70% for input current with RL load which is according IEEE 519 standards. By using FPGA SPATRAN 3E which is faster and capable enough to sense and convert the voltage and current signals and also to generate the suitable PWM signals at 10 kHz for our control strategy of the active front end converter.

References

- [1] B. Singh, B. N. Singh, A. Chandra, K. Al-Hadad, A. Pandey, D. Kothari (2003) "A Review of Single-Phase Improved Power Quality AC-DC Converters", IEEE Transactions on Industrial Electronics, Vol. 50, No 5, pp. 962-981, Oct.
- [2] Chomat M., Schreier L., Bendl J (2009)., "Operating Regions of PWM Rectifier under unbalanced Voltage Supply", International conference on Industrial Technology, Gippsland, Australia. pp.510-515 June.
- [3] Stankovic, A. V. & Lipo, T. A. (2001) "A Novel Control Method for Input Output Harmonic Elimination of the PWM Boost Type Rectifier Under Unbalanced Operating Conditions", IEEE Trans. on Power Electronics, 16, pp. 603-611, ISSN: 0885-8993.
- [4] Chomat, M. & Schreier, L. (2005). Control Method for DC-Link Voltage Ripple Cancellation in Voltage Source Inverter under Unbalanced Three-Phase Voltage Supply, IEEE Proceedings on Electric Power Applications, vol. 152, no. 3, pp. 494 – 500
- [5] Stankovic, A. V. & Lipo, T. A. (2001) "A Generalized Control Method for Input Output Harmonic Elimination of the PWM Boost Type Rectifier Under Simultaneous Unbalanced Input Voltages and Input Impedances", Power Electronics Specialists Conference, pp. 1309-1314, ISBN: 0-7803-7067-8, Vancouver, Canada.
- [6] M. Parreiras, J. C. G. Justino and B. J. C. Filho (2016), "The True Unity Power Factor Converter – A novel combination of simple well-known modulation strategy and topologies for high power conversion", in 9th International Conf. Power Electronics, Seoul, , pp. 2557-2565.
- [7] J. Kolar, F. Zach (1994) "A Novel Three-Phase Utility Interface Minimizing Line Current Harmonics of High-Power Telecommunications Rectifier Modules", Record of the 16th IEEE International Telecommunications Energy Conference, Vancouver, Canada, pp. 367-374, Oct. 30-Nov. 3.
- [8] J. Rodr'iguez, L. Mor'an, J. Pontt, J. Hern'andez, L. Silva, C. Silva, P. Lezana,(2002) "High Voltage Multilevel Converter With Regeneration Capability", IEEE Transactions on Industrial Electronics, Vol. 49, No 4, pp. 839-846, Aug.
- [9] K. Shibaue, M. Swamy, J.K. Kang M. Hisatsune. (2012) "Advantages of High Frequency PWM in AC Motor Drive Applications", ECCE.9781-1-4673-0803.
- [10] Y. Lo, T. Song, H. Chiu (2002) "Analysis and Elimination of Voltage Imbalance Between the Split Capacitors in Half-Bridge Boost Rectifier," Letters to Editor, IEEE Transaction on Industrial Electronics, Vol. 49, No 5, Oct.
- [11] Firuz Zare, Pooya Davari and Frede Blaabjerg, (2017) "A Modular Active Front-End Rectifier With Electronic Phase Shifting for Harmonic Mitigation in Motor Drive Applications", IEEE Transactions on Industrial Applications, Vol.53, No.6. pp. 0093-9994, June.
- [12] H. Karshenas, H. Kojori and S. Dewan. (1995) "Generalized techniques of selective Harmonic elimination and current control in current source inverters/converters", IEEE Transactions on Power Electronics, vol.10, No 5, pp. 566-573.
- [13] B.T.Ooi, J. W. Dixon, A. B. Kulkarni and M. Nishimoto,(1988) "An integrated AC drives system using a controlled – current PWM rectifier/Inverter Link", IEEE Transactions on power electronics, Vol.3, no.1, pp. 64-71, Jan.
- [14] H. Akagi, Y. Tsukamoto, A. Nabae,(1990) "Analysis and Design of an Active Power Filter Quad-Series Voltage Source PWM Converters", IEEE Transactions on Industrial Electronics, Vol.26, No 1, pp. 93-98, Feb.
- [15] Firuz Zare, Pooya Davari and Frede Blaabjerg,(2017) "A Modular Active Front-End Rectifier With Electronic Phase Shifting for Harmonic Mitigation in Motor Drive Applications", IEEE Transactions on Industrial Applications, Vol.53, No.6. pp. 0093-9994, June.
- [16] Y. Zhang, Q. Zhang, Z.Li and Y. Zhang,(2013) "Comparative study of model predictive current control and voltage oriented control for PWM Rectifiers", in proc 2013, international conference electrical machines system. Oct. pp.2207-2212.
- [17] Zbigniew Rymarski explains the "Control systems of single-phase voltage source inverters for a UPS", Akademia 16, Gliwice 44-100, Poland.
- [18] Venkata Ravi, Benfei Wang and Ping Lam So. (2017) "A New ZVS Full – Bridge DC-DC Converter for Battery Charging with Reduced Losses over Full – Load Range", IEEE Transactions on Industry Applications, 16, pp. 603-611.

- [19] M.P. Akter, S. Mekhilef, N.M.L. Tan and H. Akagi,(2016) “Modified model predictive control of a bidirectional ac-dc converter based on Lyapunov function for energy storage systems.” IEEE Transactions on industrial Electronics Vol.63, No. 2, pp. 704-715, Feb.
- [20] G. Grandi and J. Loncarski,(2013) “Evaluation of current ripple amplitude in three-phase PWM voltage source inverters”, in Proc.2013 8th international conference compat. Power electronics. June, pp. 151-161.

