

# Analysis of coiled spring for loading application in automotive industry

Hrishikesh Uttamrao Gadekar,  
Assistant Professor,  
Department of Mechanical Engineering,  
ISB&M School of Technology, Nande, Pune, India

**Abstract:** The Valve spring in car engine needs to withstand high number of cyclic loading; typically infinite number of times. The replacement for the spring calls for downtime of the machine with high overheads due to idle time due to maintenance. The problem for the proposed work is to design a spring for lasting the needful number of cycles without failure. The same is to be ensured through 'Fatigue Analysis' using suitable FEA software for predicting the life. The analysis is done with the help of NASTRAN software and results for wire diameter 3.5mm and 4mm are to be compared.

**Key words – CATIA, NASTRAN, HYPERMESH**

## I. INTRODUCTION

A spring is defined as an elastic machine element, which deflects under the action of the load and returns to its original shape when the load is removed. It can take any shape and form depending upon its application.

The main dimensions of helical spring subjected to compressive force are as shown in figure. They are as follows:-

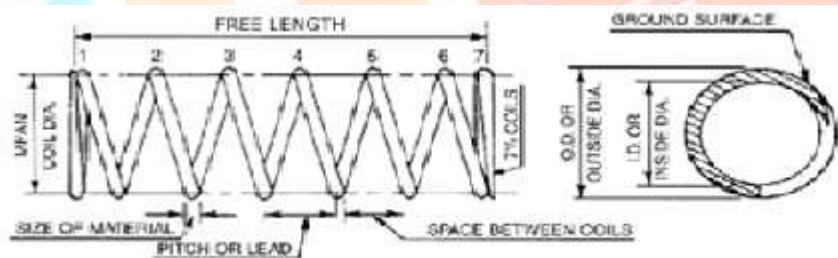

$d$  = wire diameter of spring

$D_i$  = inside diameter of spring coil

$D_o$  = outside diameter of spring coil

$D$  = mean coil diameter

Therefore,

$D = D_i + D_o / 2$ , There is an important parameter in spring design called spring index. It is denoted

by letter  $C$ . The spring index is defined as the ratio of mean coil diameter to wire diameter. Or,  $C = D/d$ .

## II. PROBLEM DEFINITION

1 To design the spring using Fatigue analysis for life enhancement of spring.

2 To reduce the incidence of fatigue failure for the working life of the component.

## III. SPECIFICATION OF A SPRING

The following table shows specification of the spring

Sr.No.	Specification	Dimension
1	Length	51.5
2	Outer Diameter	33
3	Inner Diameter	25
4	Pitch	8
5	Wire Diameter	4

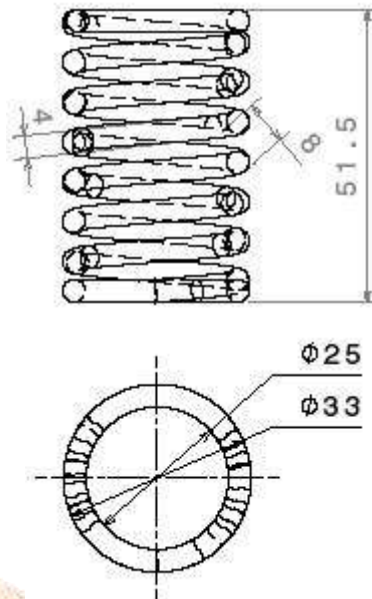

Figure 1 Valve Spring Dimensions

**IV. Methodology:**

The methodology is explained in the following flow chart diagram.

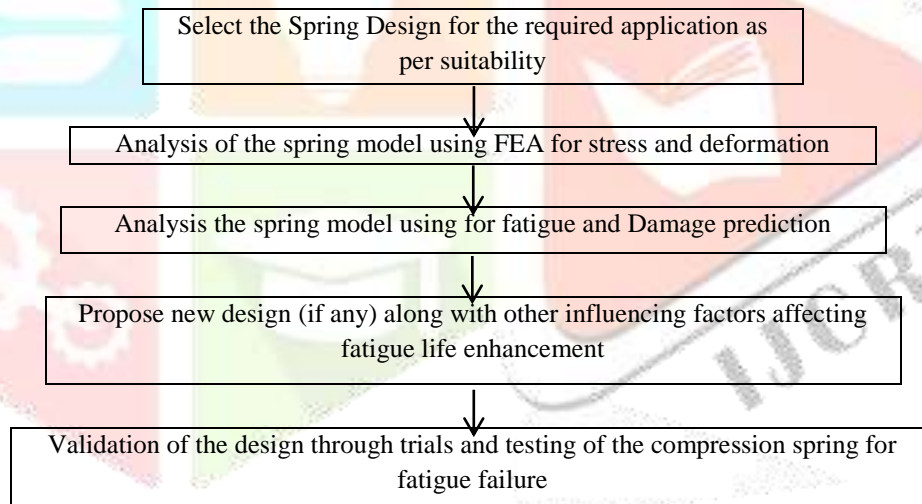

Figure 2: Methodology flow chart for the helical compression spring

**V. FEA for Original compression Spring :**

CATIA V5 model : Spring model is drawn in CATIA V5 modeling software and saved as “.CATPart



Figure 2 CATIA V5 spring model

#### Meshing Interface:

Meshing generation is a process of dividing the structure continuum into a number of discrete parts or finite elements. The finer mesh causes better results, but longer analysis time. Therefore, a compression between accuracy and solution speed is usually made. Meshed compression helical springs are shown in fig. Meshing is done in to HyperMesh v11.0 as shown in figure . Meshing is done as Hex Mesh Linear.

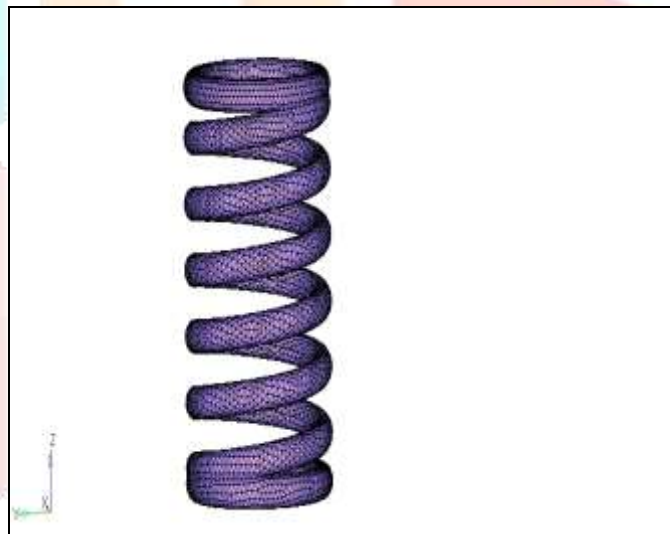

Figure 3 Hex Mesh (Linear) of compression spring

The Hex8 (Hexahedral shaped, 3Degree of freedom, linear shape element is selected for analysis. The load and constraints are applied on the mater node which is connected to the spring by ID rigid RBE2 and RBE3 element as shown as in the figure below.

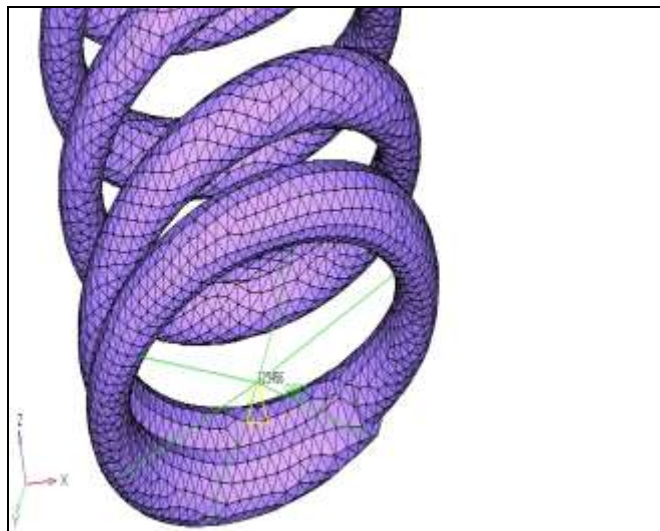

Figure 4 Fixed element connectivity

A load of  $1 \times 10^2$  N is applied on the top rigid element RBE3 at the master node, whereas the boundary condition is applied at the top bottom rigid element RBE2 at the mater node as shown in figure below.

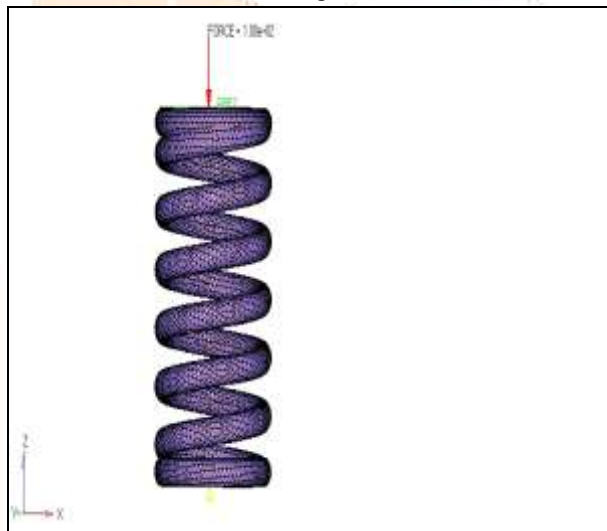

Figure 5 Compression spring with load

**VI Static structural analysis result:**

A static structural analysis is carried out with the given loading condition in the NASTRAN solver. Preprocessing of helical compression spring is done by using HYPERMESH software. Where the 3D hexahedral mesh is done and the input deck is prepared for NASTRAN solver. The result is shown in the following.

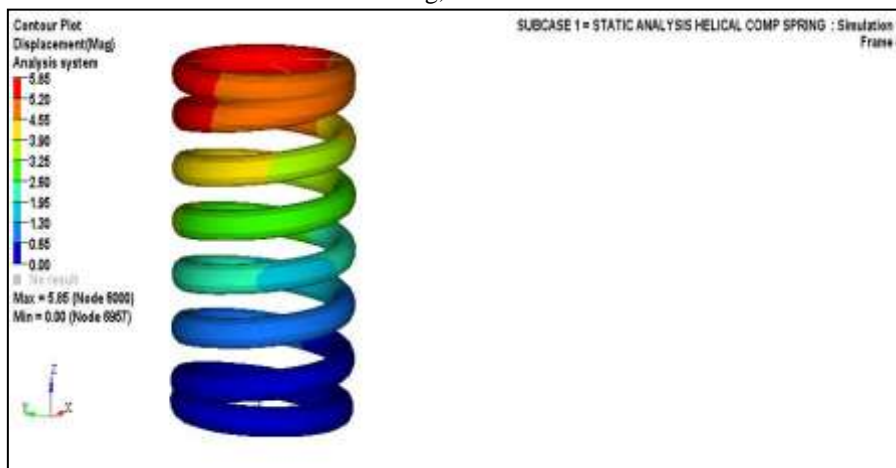

Figure 6 Maximum deflection of valve spring

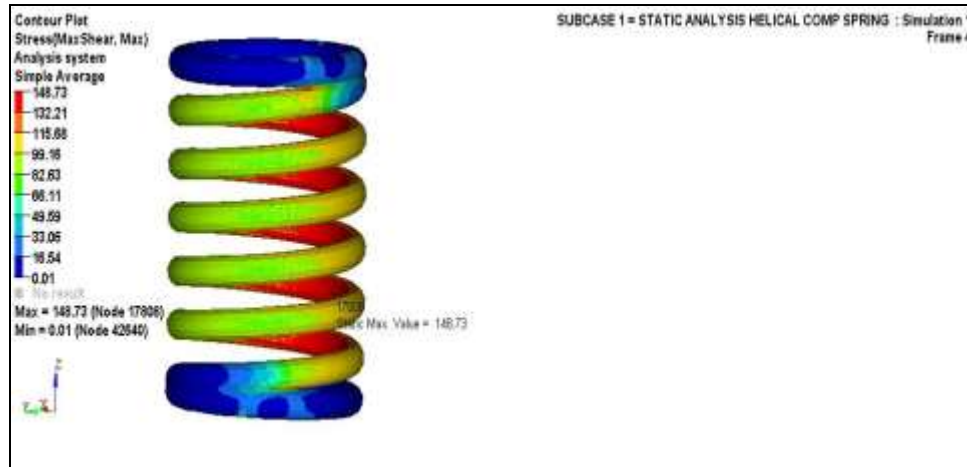

Figure 7 Maximum shear stresses in valve spring

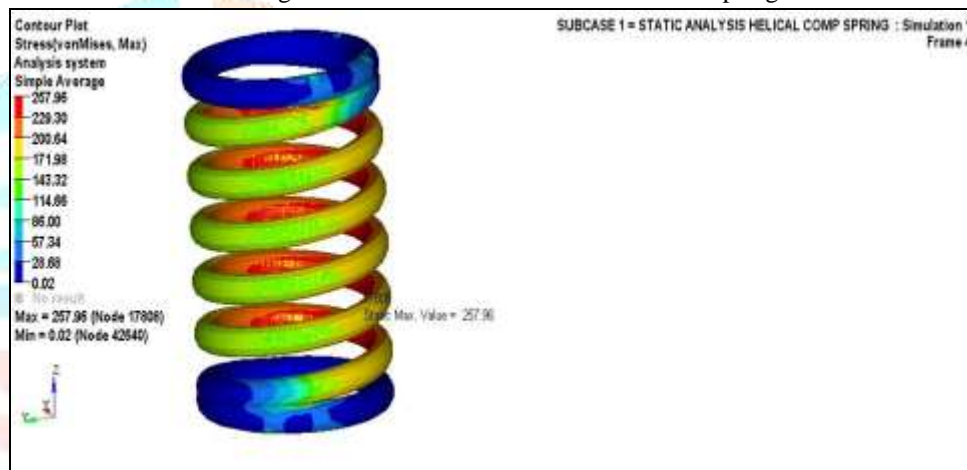

Figure 8 Maximum von Mises stress in valve spring

## VII Fatigue Analysis Result:

After NASTRAN solver the result file input deck file is imported in the MSC FATIGUE software for fatigue prediction of a given helical compression spring.

Steps in Fatigue analysis:

1. Import the hypermesh input file (.dat) in the MSC FATIGUE software.
2. Import the result file (.op2) in the same software.
3. Defining the fatigue properties as:
  - a. Solution Parameter: Fatigue solution parameter like stressed based fatigue is used by defining the SN curve with Goodman man stress for correction and the signed von Mises stresses are consider for fatigue analysis.
  - b. Material Information: Spring steel material is defined from the fatigue software library and the SAE material of the same steel spring material properties is selected and also the SN data with Young's modulus of elasticity and Ultimate tensile stress.
  - c. Loading Information: A triangular load is defined as a cyclic load acting on the compression spring the loading information and the load curve is plotted .

## VIII Spring Fatigue life predication:

Original spring fatigue simulated as per the steps given above the result is shown below:

1. Life Predication: The minimum life of spring shown in simulating is  $6.56 \times 10^4$  .

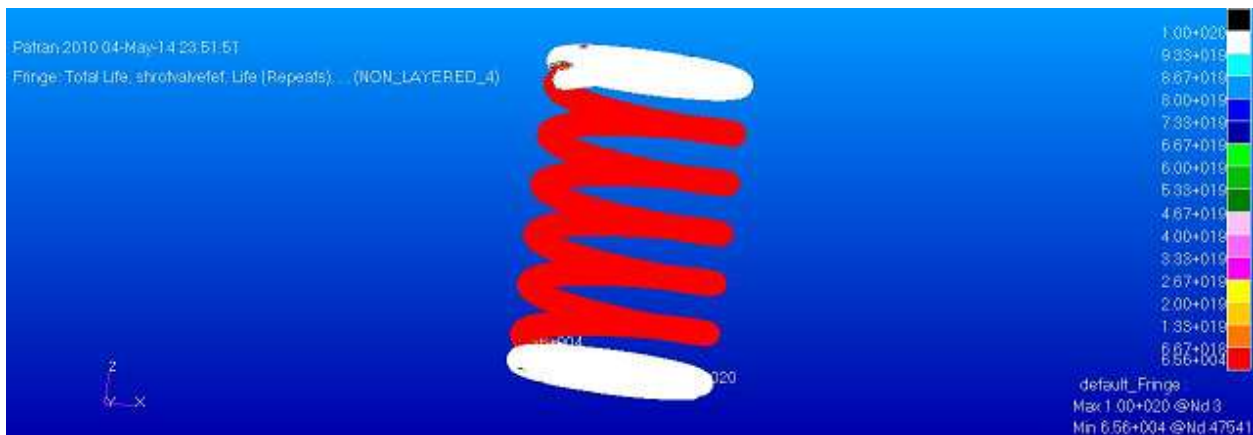

Figure 9 Total life plot of compression spring

2. Damage Detection: Damage sum must be less than zero for the cyclic loading of helical compression spring. The damage plot is shown in the figure below.



Figure 10 Damage plot of compression spring

Readings of original spring is shown in tabular form as follows:-

Spring	Displacement (mm)	Shear stress (N/mm <sup>2</sup> )	Von mises stress (N/mm <sup>2</sup> )	Fatigue life (Number of cycles)
Original	5.85	148.73	257.96	6.56x10 <sup>4</sup>

Analysis of original spring

**IX Specifications of Modified spring:**

In case of original spring the length is 51.5mm, outer diameter 33mm, inner diameter 25mm, pitch 8mm, wire diameter 4mm. For further analysis we modify the spring by keeping length constant as it is required for the case. We modify the spring by changing wire diameter and by changing pitch. From this we get four modified cases i.e. by changing wire diameter to 3.5mm

**X FEA for modified compression springs:**

Spring models in CATIA V5 R20 as shown below, as for Modified I, Modified II and Modified III, Modified IV.



Figure 11 CATIA model of Modified spring I

**XI Static structural analysis result:**

A static structural analysis is carried out with the given loading condition in the NASTRAN solver same as original valve spring. Preprocessing of helical compression spring is done by using HYPERMESH software. Where the 3D hexahedral mesh is done and the input deck is prepared for NASTRAN solver. The result is shown in the following,

For Modified compression spring I (By changing wire diameter to 3.5mm)

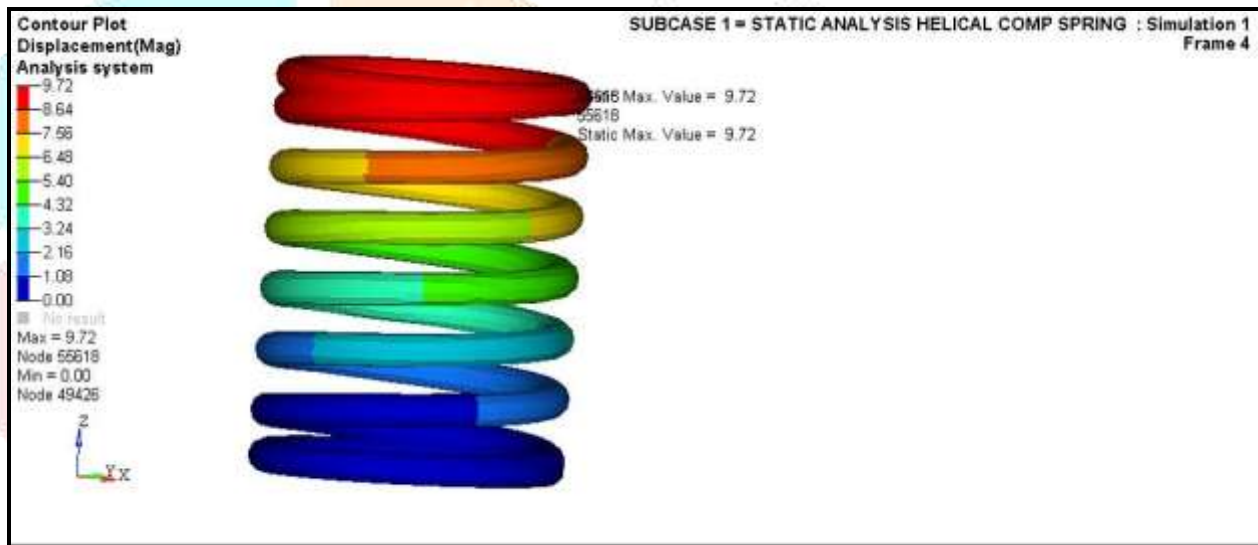

Figure 12 Maximum deflection of Modified spring I

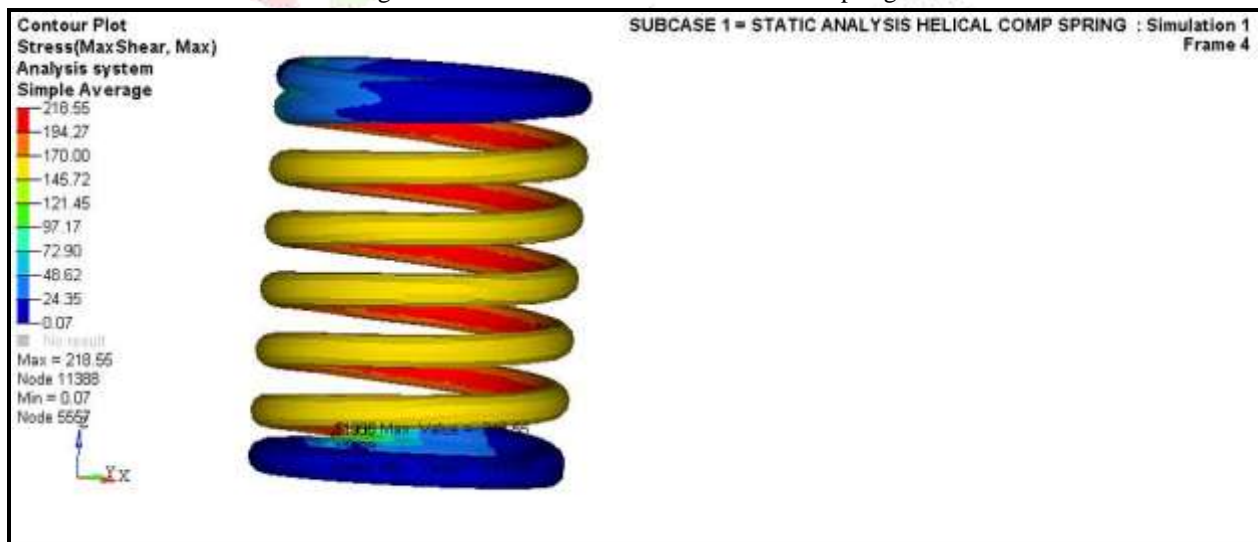

Figure 13 Maximum shear stresses in the Modified spring I

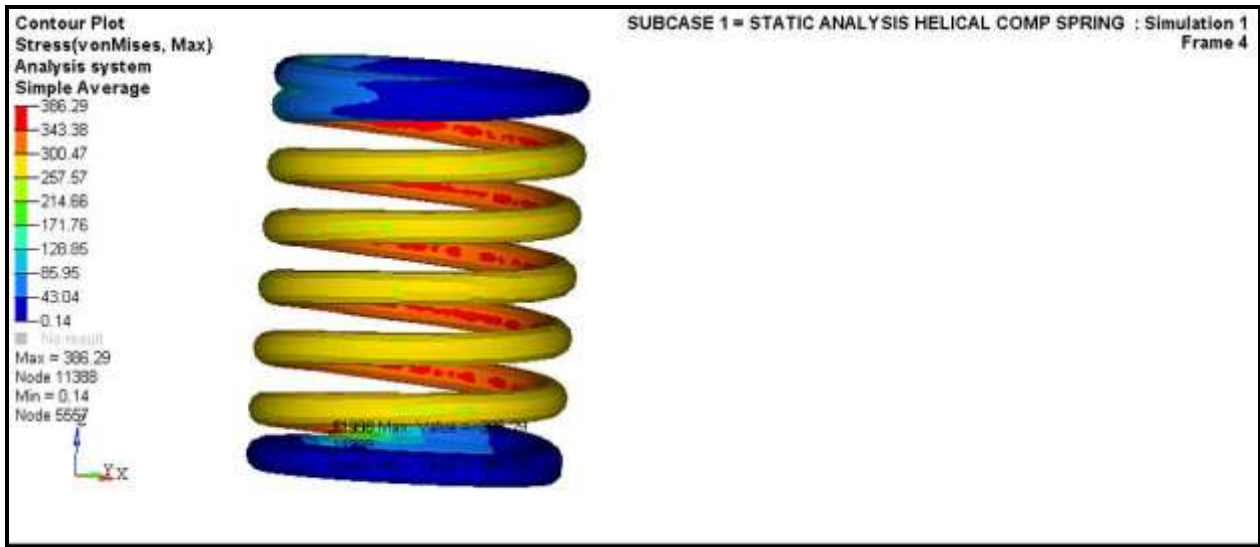

Figure 14 Maximum Von Mises stress in the Modified spring I

**XII Modified Spring I (By changing wire diameter to 3.5mm) Fatigue life predication:**

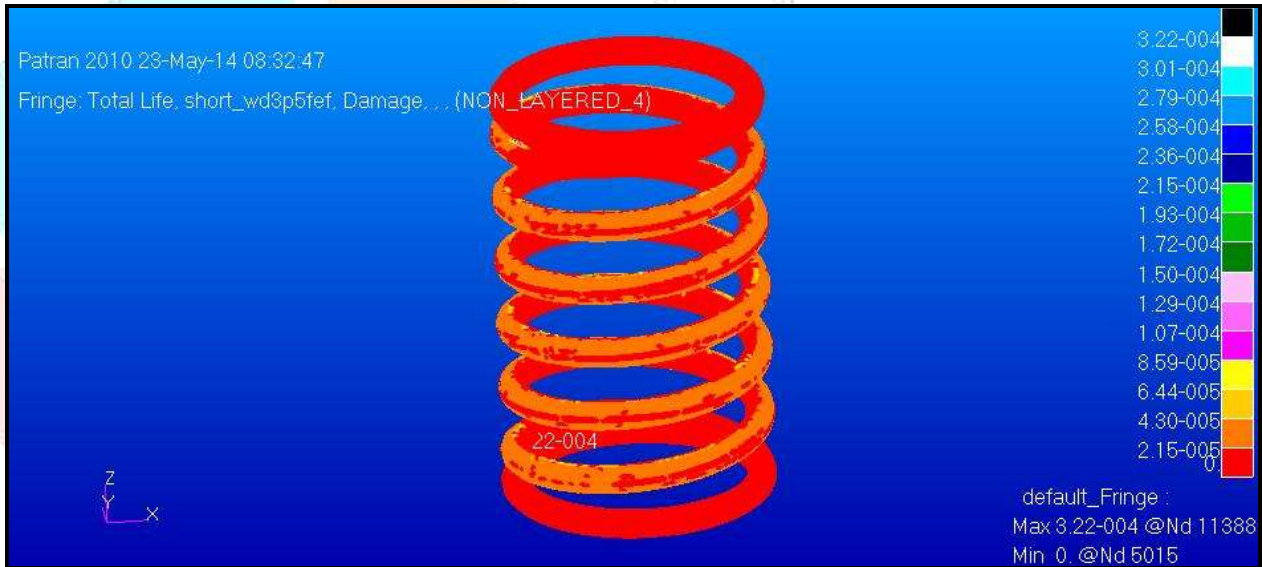

Figure 15 Damage plot of Modified spring I



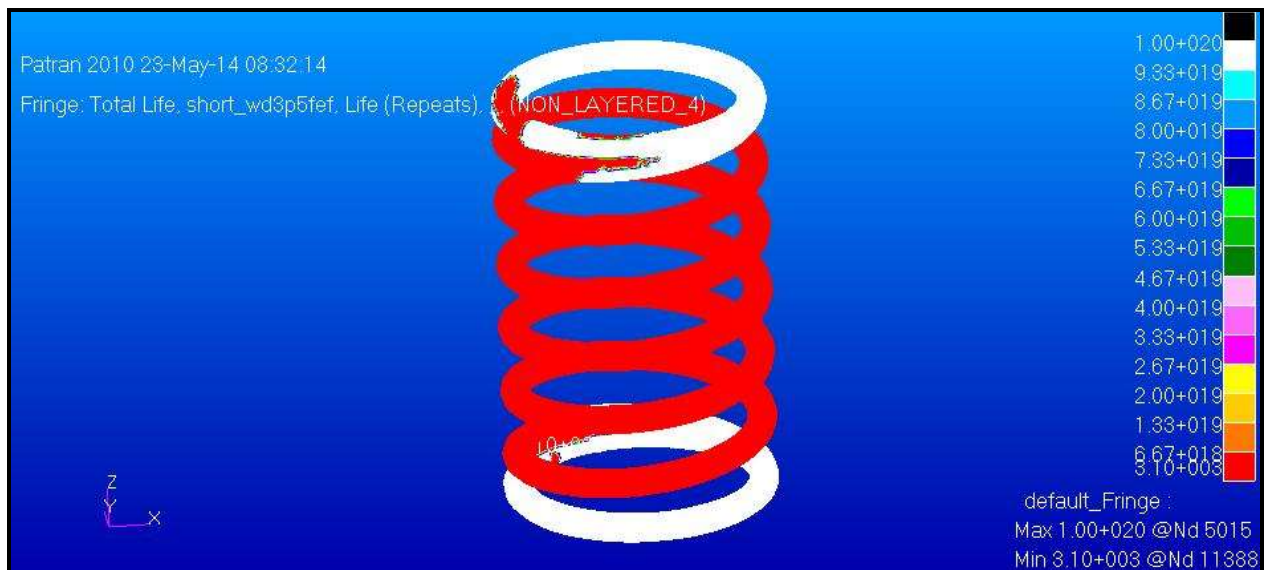

Figure 16 Total life plot of Modified spring I

### XIII. RESULTS AND DISCUSSION

Results given in table below

Springs	Displacement (mm)	Shear stress (Mpa)	Von mises stress (Mpa)	Fatigue life (Number of cycles)
Original	5.85	148.73	257.96	$6.56 \times 10^4$
Modified spring I (by changing wire diameter to 3.5mm)	9.72	218.55	386.29	$3.10 \times 10^3$

- 1) By doing analysis on original spring and we get displacement 5.85mm and fatigue life  $6.56 \times 10^4$ .
- 2) By modifying the original spring by changing its wire diameter and by changing pitch we had done analysis on modified spring then we get displacement 9.72 mm and fatigue life  $3.10 \times 10^3$  for modified spring I (by changing wire diameter to 3.5 mm).
- 3) As fatigue life for modified spring I (by changing wire diameter to 3.5 mm) is lesser than original spring so the original spring is best suitable for application of valve spring.

### REFERENCES

- [1] B. Kaiser, B. Pyttel, C. Berger. VHCF-behavior of helical compression springs made of different materials. International Journal of Fatigue 33 (2011) 23-32.
- [2] B. Pyttel, I. Brunner, B. Kaiser, C. Berger, M. Mahendran. Fatigue behavior of helical compression springs at a very high number of cycles- Investigation of various influences. International Journal of Fatigue xxx (2013) xxx-xxx.
- [3] C. Berger, B. Kaiser. Results of very high cycle fatigue tests on helical compression springs. International Journal of Fatigue 28 (2006) 1658-1663.
- [4] L. Del Llano-Vizcaya, C. Rubio-Gonzalez, G. Mesmacque, T. Cervantes-Hernandez. Multiaxial fatigue and failure analysis of helical compression springs. Engineering Failure Analysis 13 (2006) 1303-1313.
- [5] Reza Mirzaeifar, Reginald Desroches, Arash Yavari. A combined analytical, numerical and experimental study of Shape-Memory-Alloy helical springs. International Journal of Solids and Structures 48 (2011) 611-624.
- [6] Y. Prawoto, M. Ikeda, S.K. Manville, A. Nishikawa. Design and failure modes of automotive suspension springs. Engineering Failure Analysis 15 (2008) 1155-1174.
- [7] B. Pyttel, D. Schwerdt, C. Berger. Very high cycle fatigue-is there a fatigue limit. International Journal of Fatigue 33 (2011) 49-58.
- [8] Sid Ali Kaoua, Kamel Taibi, Nacera Benganem, Krimo Azouaoui, Mohammed Azzaz. Numerical, modeling of twin helical spring under tensile loading. Applied mathematical modeling 35 (2011) 1378- 1387.