

# A INNOVATIVE APPROACH IN THE FIELD OF PROCESS CONTROL-THROUGH CLOUD COMPUTATION

<sup>1</sup>Kiruba R , <sup>2</sup>Aravinth P , <sup>3</sup>Durgashri R, <sup>4</sup>Saranya S, <sup>5</sup>Sarathkumar P

<sup>1</sup>Assistant professor, <sup>(2,3,4,5)</sup>UG Scholar

<sup>1</sup>Department Of Electronics And Instrumentation Engineering

<sup>1</sup>SNS College of Technology, Coimbatore, India

**Abstract:** In Industries the level measurement and control is much important since the level is one aspect which intends to change or disturb other parameters. On a part of controlling levels in tanks in industrial applications the internet of things concept is implemented in which Raspberry pi is used to acquire values and send the datas to the cloud. This project deals with the implementation of the level process control system Without any use of external controller but using a ESP8266(Wi-Fi Module) data is acquired and send to the cloud database. In this proposed system cloud acts as a controller to store and react to set point data automatically.

**Index Terms - Internet of things,raspberry pi,cloud controller,ESP8266.**

## I. INTRODUCTION

Level measurement is important in industries where level is to be maintained constant. So it's necessary to monitor the level in many of the process. This project will help to automate and monitor any level process from any part of the world. This is done by cloud computing. Connecting devices with internet has make the monitoring job as a easy task. In general, industries are using PLC to automate a process but they face many problems in automating it. After the generation of PLC, raspberry pi is used to control the level process. In which IoT concept is interpreted to control and monitor the process. The data's from sensor is fed to raspberry pi which acts as a central processing unit, and then it is sent to the cloud server. The data's are then monitored in a mobile application. Internet of Things has greater advantage in future which can automate the whole world. Through protocol we can communicate with the other devices. It is seemed that many billions of devices are connected to the internet. Automation is the main future work of IoT. Internet of Things (IoT) is the technology which can connect many things to the internet. Connecting devices with internet enables these devices to collect data and send them to cloud. With the help of software, the program was done as per needs. Programming is done in cloud. Data are fed to the cloud server with greater speed to long distance from remote areas and received at the desired point.

## II. CHALLENGES

In PLC there is still a lot of wire to deal with. There is a need for a observer and analyst to monitor the level process. But in some chemical industries human cannot go near the process since it may be harmful, in such cases its not applicable. So this project has the scope that even in that chemical industries in which human cannot approach, it is still able to maintain and monitor the level from anywhere through internet. The use of process models in mineral industry with the concept of advanced process control. The requirements for wireless in process automation and the implementation of wireless sensor network(WSN) technology on industrial process monitoring and control with a review of the advantages of adopting WSN technology for industrial control. As Internet connections got faster and more reliable, a new type of company called an Application Service Provider or ASP started to appear. So the main objective of this paper is to control a process anywhere using cloud computation.

## III. SYSTEM OVERVIEW

In the proposed methodology, the level monitoring system is done with the help of cloud controller. The level is measured by a Float sensor. The datas from sensor was given to the cloud via ESP 8266(wi-fi module) and monitored using monitoring device. In this method cloud is used as a controller to store and react to set point data automatically. This method admit the user to access the data at any time& anywhere from the internet.

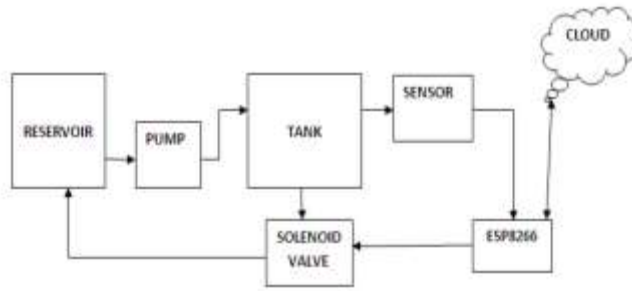

Figure 3.1: Block Diagram

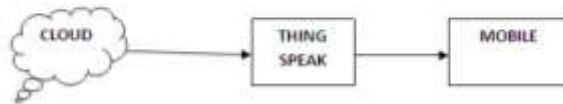

Figure 3.2: Monitoring And Control

Eclipse is an integrated development environment (IDE) used in computer programming, and is the most widely used Java IDE. The data from the field should be transmitted to the cloud through a wi-fi module ESP8266. The API key of thingspeak was included in the program, so that the data can be sent to the particular channel in thingspeak. These programs can be done in eclipse. In other words, it is used to build our customized software. To run this eclipse software, Java runtime environment (JRE) was needed. There are many versions in eclipse but here, eclipse neon was used.



Figure 3.3: Eclipse Software

ESP8266 is a wifi SOC (system on a chip). The supply voltage for ESP8266 is 3.3 V. The adapter voltage is 5v, so it is signal conditioned and then given to the ESP module.

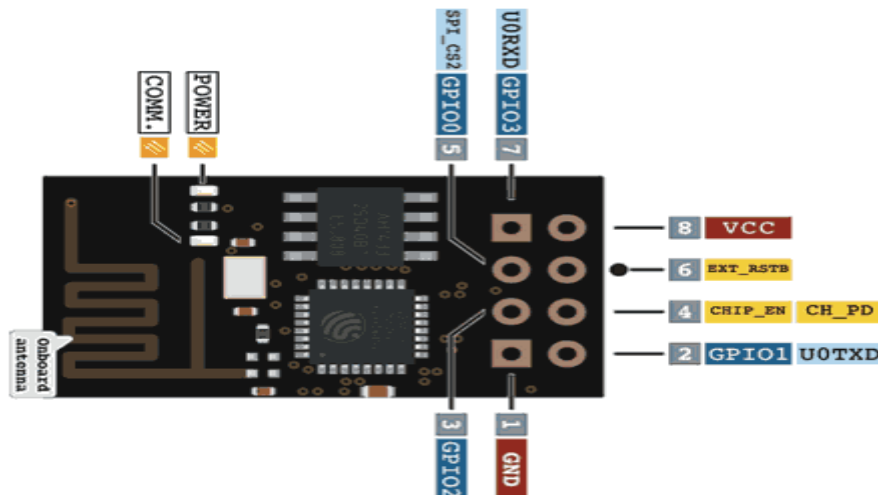

Figure 4.3 pin diagram of ESP8266

#### IV. RESULT ANALYSIS AND LIMITATIONS

##### 4.1 Result analysis

The analysis and the performance characteristics of the level system is explained below. The following are the experimental results. The data is sent via internet to the thingspeak.

Table 4.1: Output Analysis

SET POINT	CONTROL ACTION
100	TAKEN
50	TAKEN

The set point is given through a mobile and the data from level tank is given to the cloud controller via ESP8266. When the data from sensor exceeds the set point level. Then the control signal is passed from cloud to the pump to turn off the pump.

##### Trail 1

Here the set point was assigned as 100 through a mobile device and the data is collected from sensor was updated and once it reaches the setpoint the pump was turned off via the control signal from cloud controller.

##### Trail 2

Similarly the set point 50 was given via the mobile device and simultaneously the data from sensor was updated. When the sensor value attains the setpoint then the control signal reaches the pump to turn it off.

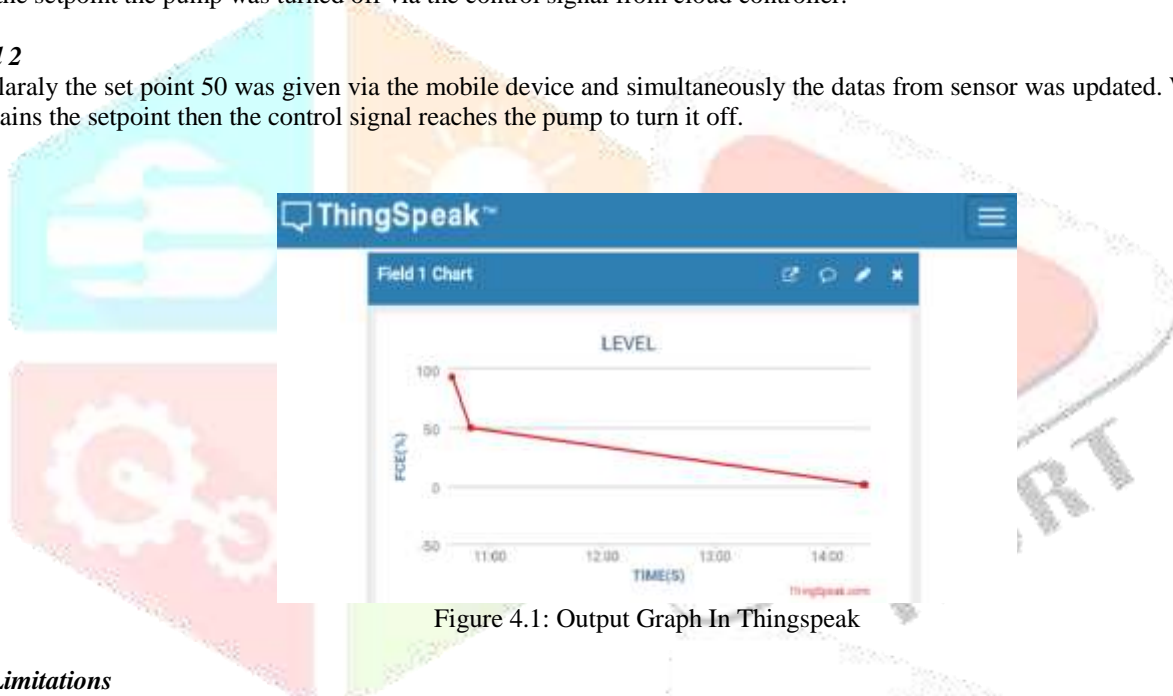

Figure 4.1: Output Graph In Thingspeak

##### 4.2 Limitations

1. There is delay for control actions.
2. The privacy is the major problem in cloud computing. But still it can be overcome with some advanced future works.

#### V. CONCLUSION

Level is the important physical variable of the industrial process and IoT is taken in account for monitor and control. Implantation of this project using PIC controller and ESP8266 for level monitoring is a new method to monitor level process industrial plant which designed here for real time application. It supports online supervision of level process not only within private network (LAN) but also in public network. The main conclusion drawn from this study is that a low cost level monitoring and controlling system was built using PIC controller and cloud computing. This proposed methodology has improved much better with remote access in monitoring of level with the advanced cloud controller. The project has Cloud as a controller and as a source to store data. But only one parameter is monitored and controlled. In future works, more than one parameter could be monitor and controlled.

#### VI. ACKNOWLEDGMENT

We extend our sincere thanks to Our Parents and Almighty for the plausible support and abundant blessings.

#### REFERENCES

- [1] Aguaran K & J. Thiyagarajan, "Raspberry Pi Based Global Industrial Process Monitoring Through Wireless Communication", International Conference on Robotics, Automation, Control and Embedded Systems – RACE 2015, 18-20 February 2015.

- [2] Ahmed Abdullah et al., “Water Level Indicator With Alarms Using PIC Microcontroller”, American Journal of Engineering Research, volume 4, Issue 7, 2015.
- [3] AmitRana& A.S. Bhalchandra,“ Machine Monitoring on Cloud using Raspberry Pi and Internet of Things”, International Journal of Advanced Research in Computer and Communication Engineering Vol. 5, Issue 1, January 2015.
- [4] Andrea Zanella, et al., Senior Member, IEEE “Internet of Things for Smart Cities”, IEEE Internet of Things Journal, Vol. 1, No. 1, February 2014.
- [5] Angeline Vijula.D et al, “Controlling and monitoring of industrial pressure processing distributed control system”, International Journal of Innovative Research in Electrical , Electronics, Instrumentation and control Engineering, Vol. 3, Issue 2.

