

Comparative Survey of STATCOM and SVC Integration for Power System Stability Improvement

¹Nsengiyumva Joseph,

Masters student in Electrical Engineering,
Department of electrical Engineering
Parul University, India, Gujarat, Vadodara

² KrunalSinh Dattesh,

Professor in Parul University
Department of Electrical Engineering
Parul University, India, Gujarat, Vadodara

Abstract: Nowadays there is a development of the modern power system that led to an increasing in complexity in the study of power systems, and also brings new challenges to power system stability, and especially, to the aspects of transient stability and small-signal stability. This paper discuss an application of STATCOM(Static Synchronous Compensator) and SVC(Static Var Compensator), for effective improvement of power system stability by regulation of system voltage and the comparative study on different features of STATCOM and SVC is made through the review of papers and books such as v-i characteristic of STATCOM and SVC , dependence on common coupling point voltage of STATCOM vs SVC, response time of STATCOM vs SVC, system stability enhancement, V-Q characteristics of STATCOM and SVC cost of STATCOM vs SVC and voltage regulation capability. A comparative study on effectiveness of STATCOM and SVC in improvement of system stability is found that STATCOM is more effective than SVC to ensure voltage stability even if both contribute to power system stability improvement.

Index Terms – Voltage regulation, STATCOM, SVC, Transient Stability, and Response time.

I. INTRODUCTION

As there is an inter-connection of large regional power systems and the rapid development of power system, the modern systems becomes a more large nonlinear dynamic system, including large capacity units, extra high voltage, long distance transmission, complex distribution network and heavy load demand. Particularly the type of air condition load and industrial loads which is more inductive will absorb more reactive power from the system during grid faults, further deteriorate the system voltage stability, even lead to large area blackout, and seriously influence the transient stability of the power systems. By reason of that, there is a need to compensate the required reactive power during the grid faults and dynamic support the system voltage becomes an important concerned subject where Facts devices come as solution. In this paper STATCOM and SVC has been discussed [1].

The STATCOM is fundamentally a shunt connected switching converter type VAR generator. This switching converter may be Voltage source converter or current source converter. In general voltage source converter is used. The basic block diagram of a STATCOM is given in fig1. The voltage source converter uses self-commutating switches like GTO, IGBT which has advantages over VAR generators (SVC, TCR, TSC) such as faster response and require less space [2].

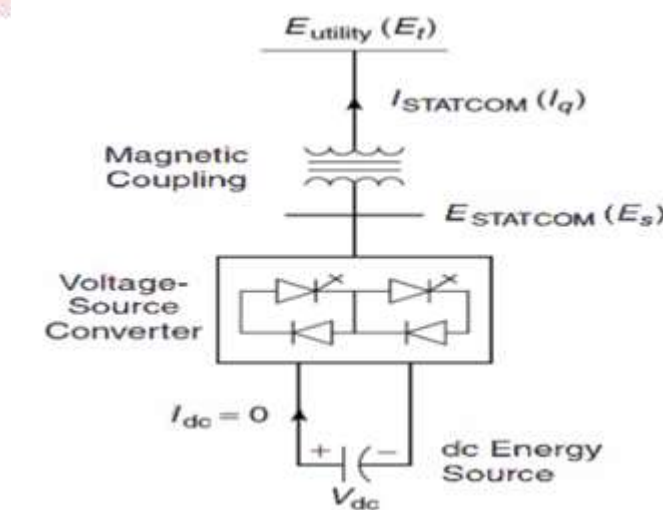

Fig1. Block diagram of STATCOM [2]

The Static Var Compensator (SVC) is a shunt connected device in family of the Flexible AC Transmission Systems (FACTS) using power electronics to control power flow and improve transient stability on power systems. The SVC regulates the system voltage by adjusting the output equivalent impedance. As STATCOM the SVC also can absorb and inject reactive power according to conditions of network but STATCOM has some advantages over SVC.

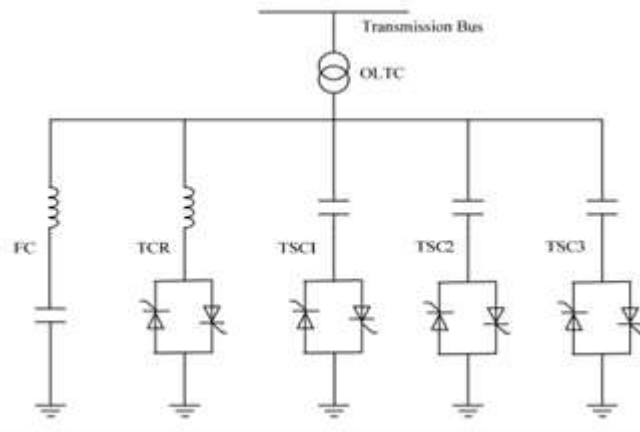

Fig2. Block Diagram of SVC

During normal conditions, continuous regulation of reactive power is realized by TCR which series with reactor and two anti-parallel thyristors. Whenever the system voltage reduces below the rated operating range, SVC will inject the maximum reactive power into the system and perform pure capacitance characteristic but the capacity of reactive power to be injected will reduce with the reduction of the system voltage.

II. V-I CHARACTERISTIC OF STATCOM AND SVC

Referring to the curves which relate voltage magnitude to current (VI) for the aim of voltage support capabilities is common. A decrement in system load level will result in an increase in voltage magnitude at all system nodes. Both the SVC and the STATCOM keeps the voltage magnitude by absorbing inductive current. On the other side, an increase in the system load level produces a decrease in nodal voltage magnitudes. For this condition, the devices maintain the voltage magnitude by injecting a capacitive current. In Fig.3, there are the VI curve for the SVC and the STATCOM.

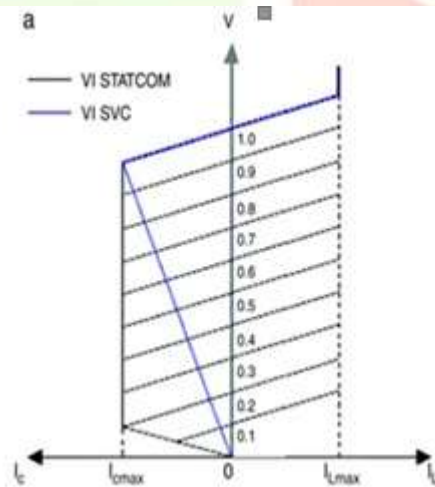

Fig.3 V-I Characteristic of STATCOM and SVC

From Fig. 3, we see that STATCOM's ability to provide current compensation is more extensive than the SVC's; even at low voltages levels the STATCOM can continue to supply the full rated reactive current to the system. Even at low as 0.15 pu fig3, demonstrate that the STATCOM has increase transient rating in both capacitive and inductive region, means that the output current is independent of the system voltage, whereas the compensating current of the SVC decreases linearly with the system voltage. Maximum allowable junction temperature of the converter switches determines the transient rating of STATCOM[2]. Remember that SVC can be operated in two different modes, first mode is In voltage regulation mode where the voltage is regulated with-in limits as explained below, second mode is in VAR control mode where the SVC susceptance is kept constant.

III. DEPENDENCE ON COMMON COUPLING POINT VOLTAGE OF STATCOM vs SVC

As STATCOM works as a controllable voltage source while SVC works as dynamically controllable reactance which is connected in parallel. This makes STATCOM continues to provide the maximum reactive current even at low voltage this possible for the reason that in every equilibrium condition the injected reactive power varies linearly with the voltage of the point of common coupling. STATCOM can output rated reactive current even under low system voltage, which makes it more effective in improving the transient stability of the power systems [3]. By other side, for SVC there is a quadratic dependence of the reactive power injected by SVC on the voltage level at the common coupling point (PCC), the capacity of injecting reactive power will decline with the decline of the system voltage. Which means that to inject the same amount of reactive power it is required to install a SVC with a nominal capacity higher than that of a STATCOM [4].

IV. RESPONSE TIME OF STATCOM vs SVC

During power system transient process the duration of fault is 0.1 second, which shows that the response time of the device determines directly the transient support ability of the compensation device [5].

As the SVC is made by the switching devices with TCR/TSC are half-controlled thyristor and cannot be turned off only when current zero-crossing occurs, so there is a control delay. Linked with transition time of the equipment, the response time of SVC is up to two to three cycles. Meanwhile the switching device used in STATCOM are composed of full-controlled device IGBT/GTO with high switching frequency, so control delay is almost neglected, the response time is basically determined by the inherent time constant of the device (generally only a few milliseconds). As a result, the entire response time of STATCOM is only one frequency cycle, sometimes even up to only half frequency cycle. So we conclude that the response time of STATCOM is better than the one of SVC.

V. SYSTEM STABILITY ENHANCEMENT

As there is development of modern power system which led to an increase in complexity of power system and presents new challenges to power system stability such as transient stability and small signal stability. To ensure those stability the control of reactive power and active power is necessary which can be achieved by integration of FACTS Devices like STATCOM and SVC [6].

It is found that both STATCOM and SVC have good performance on reactive power compensation and improvement of system stability but comparing the effects of STATCOM and SVC on transient stability performance of system, the result of comparison gives that STATCOM provides the better result than SVC. STATCOM is better than SVC for improvement of transient stability as having faster response than SVC and reactive current to be injected is independent of the system voltage which is not the case for SVC [6]. The STATCOM provides superior performance than SVC for bus voltages, power measurement, and rotor angle and terminal voltages of the multi-machine system. For the multi-machine system, the best performance has been obtained by integrating FACTS devices such as SVC and STATCOM which compensate reactive power, increased transmission system reliability and availability, increased dynamic and transient grid stability and reduction of loop flows.

VI. VOLTAGE STABILITY BIFURCATION CONTROL

Voltage stability bifurcation is the delay or elimination of the potential bifurcation phenomenon to the voltage stability in the electric power system with the use of various bifurcation control methods [7]. By using the 3-node system with an SVC compensator as an example, and direct feedback control method was applied, to design an SVC non-linear controller, in the reason of delaying the unstable Hopf bifurcation (UHB) and the time that the load bus voltage breaks down [8].

It is found that both SVC and STATCOM compensation could efficiently delay the occurrence of saddle-node bifurcation (SNB) in the two systems, and as greater as gains of the compensation devices are but the better the control effect to SNB point is; and STATCOM always takes better than SVC whenever the same value of their gains is concerned [9]. The simulation result of the single-machine PQ dynamic-load (SMDL) system shows the saddle-node bifurcation boundary partially comparative curves as presented in figure 4. The curves in figure 4 reveals that when the gain has the value of 0, the bifurcation parameter P has the same value of the parameter value of saddle-node bifurcation point which comes out in a system without reactive power compensation. Referring to Figure 4, it shows that with the gain values of SVC and STATCOM grow, the bifurcation parameter P emerging at the SNB point also increases, which means the SNB would be delayed. On the other side, under the condition taking the same gain value ($K_{stat}=K_{svc}>0$), STATCOM is more effective on delaying the system SNB point than what SVC can provide.

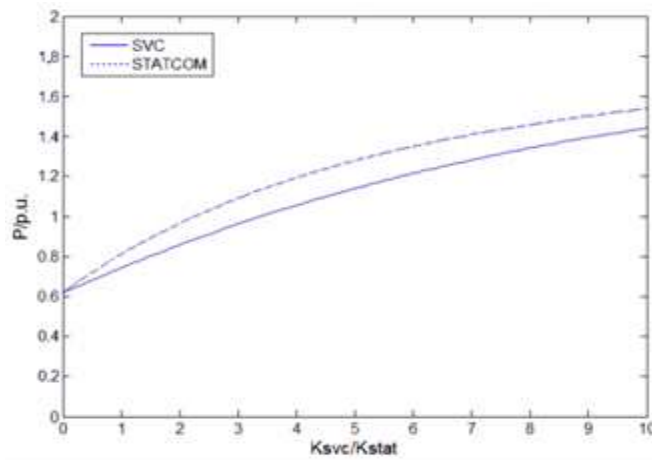

Fig4 The SNB boundary curves [9]

It can be concluded that the bifurcation control ability of STATCOM for voltage stability is greater than that of SVC.

VII. VOLTAGE REGULATION

Both SVCs and STATCOMs contribute to changes in power system operating conditions fast and continuously. Actually, the size of the reactive compensators (SQ) is determined by the network short circuit capacity (SSC). Normally a ratio of 5% (SQ/SSC) is selected. This section shows the impact of SVCs and STATCOMs on the bus voltage for deviation of the network strength from the nominal point in case of under voltage and overvoltage [10].

As power flow is given by the following equations, the equations below are valid for power flows.

$$P = \frac{E \cdot V}{X} \sin \alpha \tag{1}$$

$$Q = \frac{E(E - V \cos \alpha)}{X} \tag{2}$$

- Where
- P= Active power flow
 - Q= Reactive Power Flow
 - E= sending end voltage
 - V= Receiving end voltage
 - X= Reactance of the line connecting the receiving end to sending end

It is found that with the same rating of reactive power, STATCOMs gives voltage regulation more effectively than SVCs during under voltage time. The fig.5 represents how a dynamic compensator reacts with increase of network reactance, SVCs and STATCOMs regulate the load voltage up to a value near $X_s=0.25$ p.u above this level, both compensators reach their limit. As STATCOM operates as a constant current source and SVCs operate as a shunt capacitor in case of under voltage. STATCOM contributes to the voltage regulation better than SVC by a factor near 1.7%.

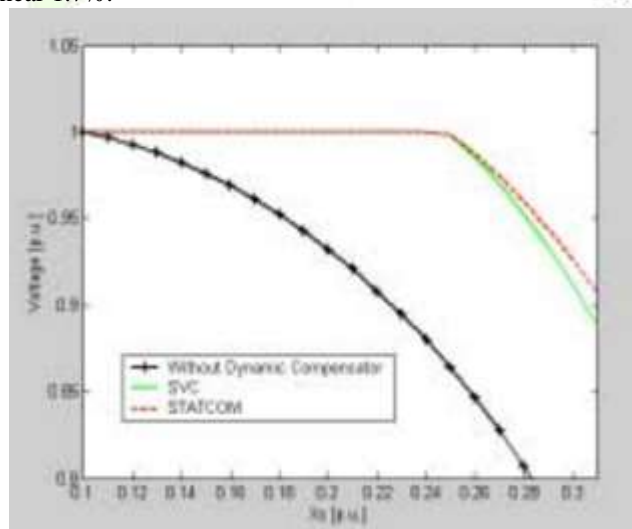

Fig5. Voltage variation with change in source reactance [11]

For overvoltage case, to represent more clearly the behavior of SVCs and STATCOMs with respect to overvoltage, the load Size is chosen to be 4 Pu. With same model as for under voltage it is found that SVC contributes to voltage regulation more effectively than STATCOMs during overvoltage period as shown in fig6. So by conclusion, on voltage regulation STATCOM gives support to voltage regulation more effectively than SVCs during under voltage period, while SVC gives support to voltage regulation more effectively than STATCOMs during overvoltage period.[11]

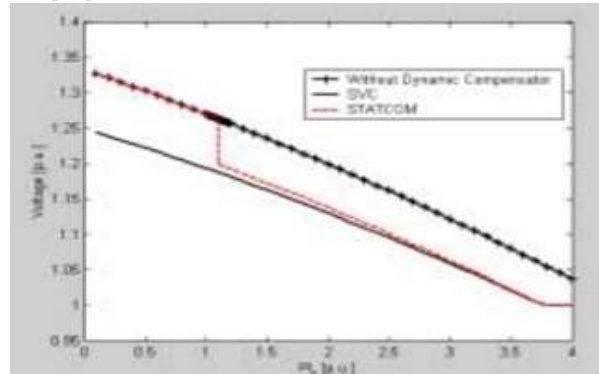
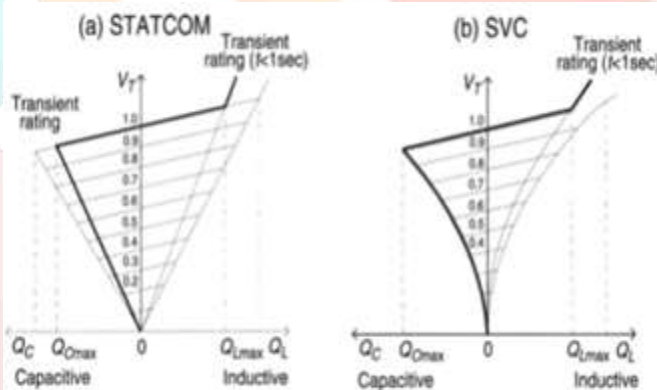

Fig6. Clarification of overvoltage for the simple power system [11]

VIII. V-Q CHARACTERISTICS OF STATCOM AND SVC

Fig.7 below, shows that the maximum VAR generation or absorption of the STATCOM changes linearly with the system voltage, whereas the SVC the VAR output decreases as the square of this system voltage. In addition, the SVC cannot transiently increase the generation of VAR since the high capacitive current consumed is depending strictly by the size of the capacitor bank and the system voltage magnitude.



V-Q Characteristics of STATCOM and SVC [12]

As it is possible to maintain the maximum capacitive or inductive output current of the STATCOM independently of the AC system voltage, so the maximum var generation or absorption changes linearly with the AC system voltage in STATCOM. But as SVC is composed of thyristor switched reactors and capacitors, becomes a fixed capacitive admittance at full output, so the maximum achievable compensating current of SVC decreases linearly with AC system voltage and the maximum var output reduced with the square of this voltage. STATCOM is therefore better to SVC in providing voltage support under large disturbances.

IX. COST OF STATCOM vs SVC

Both STATCOM and SVC the costs can vary depending on voltage, and requirements, construction time, maintenance operation and repair, workers, substation equipment, access, roads, service, permits, licenses and financing. For the STATCOM, the specific costs depend on the transformer, the DC source, the semiconductors and the respective snubber to protect them. While for SVC cost is closely depending on passive elements such as inductors and capacitors composing TCR and TSC. Table 1, shows cost comparison between SVC and STATCOM.

Table-1. Cost comparison of STATCOM and SVC[13]

Tips	Comparison
Civil engineering cost	Cost STATCOM about 80% the cost SVC
Electromechanical engineering	Cost SVC about 90% the cost STATCOM
Put into service, Protection, control and measurement equipment	Cost SVC about 75% the cost STATCOM

Generally, the STATCOM is more expensive than the SVC but the physical size of STATCOM of same rating with SVC is less, the installation of an SVC influences civil engineering cost. Thus, the civil engineering cost of a STATCOM is 80% that of a SVC of the same electrical characteristics. At present, the cost of the STATCOM seems to be competitive with the SVC. The above due to potential applications of STATCOM have demonstrated more robust.

X. CONCLUSIONS

In this paper a comparative study of SVC and STATCOM for Power system stability enhancement in different features is discussed. The different operating condition of SVC and STATCOM under various load conditions and conditions are also discussed. At the end it is proved that STATCOM gives better voltage stability compared to that of SVC with consideration of voltage stability and speed of response and it is observed that both SVC and STATCOM are able to improve voltage stability as well as power system stability. It is found also that the STATCOM is more expensive than the SVC but the physical size of STATCOM of same rating with SVC is less but at present, the cost of the STATCOM seems to be competitive with the SVC.

XI. ACKNOWLEDGEMENT

It is gratifying to express my indebtedness to those who gave me notable assistance to bring this paper work to a successful completion. I also give my profound and heartfelt gratitude to my guide Prof. Krunal Sinh Dattesh and Head of department of Parul Institute of Engineering and Technology painstakingly supervised the script by offering countless suggestions, guidelines and constructive criticisms. Their pieces of advice, corrections and encouragement contributed momentously to the success of this paper.

REFERENCES

- [1] Y. Wang, H. Chen and R. Zou, 2000. A non-linear controller design for SVC to improve power system voltage stability, *Electrical Power and Energy Systems*, vol. 22: 463-470.
- [2] Prashant Kumar, 2015. Application of Fact Devices for Voltage Stability in a Power System, IEEE Sponsored 9th International Conference on Intelligent Systems and Control (ISCO).
- [3] Ainsworth J D, Davies M, Fitz P J, et al ,1998. Static var compensator (STATCOM) based on single-phase chain circuit converters, *IEEE Proceedings-Generation, Transmission and Distribution*, 145 (4).381-386.
- [4] Boqiang Xu and Xia ChenBhatti. Comparative study on System Transient Stability using Cascade STATCOM and SVC, School of Electrical and Electronic Engineering' North China Electric Power University' Baoding071003, China.
- [5] An Luo, Zhikang Shuai, Wenji Zhu, 2009. Combined System for Harmonic Suppression and Reactive Power Compensation, *Industrial Electronics, IEEE Transactions on*, vol.56, no.2, and pp.418-428.
- [6] Prity Bisen and Amit Shrivastava, 2013. Comparison between SVC and STATCOM FACTS Devices for Power System Stability Enhancement, *International Journal on Emerging Technologies* 4(2): 101 -109(2013).
- [7] Guangdong Chen, Jorge L. Moiola and Hua O. Wang, 2000. Bifurcation control: theories, methods, and applications, *International Journal of Bifurcation and Chaos*, vol. 10, no. 3: 511-548.
- [8] Y. Wang, H. Chen and R. Zou, 2000. A non-linear controller design for SVC to improve power system voltage stability, *Electrical Power and Energy Systems*, vol. 22: 463-470.
- [9] Sheng LI Qi ZHAO and Cheng CHEN Yan XU, 2012. A Comparative Study on Voltage Stability Bifurcation Control Ability of SVC and STATCOM, *China International Conference on Electricity Distribution (CICED 2012)*.
- [10] A. E. Hammad, 1996 "Comparing the Voltage Control Capabilities of Present and Future Var Compensating Techniques in Transmission Systems, *IEEE Transaction on Power Delivery*, Vol. 11, No. 1.
- [11] M. Noroozian and C.W. Taylor, Benefits of SVC and STATCOM for Electric Utility Application.
- [12] P. Nagendra, T. Datta, S. Halder and S. Paul 2010. Power system voltage stability assessment using network equivalents - A review, *Journal of Applied Sciences*, vol.10, no.18, and pp.2147-2153.
- [13] E Barrios-Martinez, 2017. Technical comparison of FACTS controllers in parallel connection, *Journal of applied Research and technology*. Volume 15, issue1 February 2017, Pages 36-44.