

Hybrid Generation system with inter connection of PV-Wind-Battery based Multi-Input Transformer Coupled Bidirectional DC-DC Converter with multilevel inverter fed AC load

ARETI.GOPI

M.TECH student, Dept. of Electrical & Electronic Engineering: Nova College of Engineering & Technology, Jupudi, Andhra Pradesh, India.

Abstract: In this project, a control strategy for power flow management of a grid-connected hybrid PV-wind-battery based system with an efficient multi-input transformer coupled bidirectional dc-dc converter is presented. The aim of our project is to satisfy the load demand, manage the power flow from different sources, inject surplus power into the grid and charge the battery from grid and when required. A transformer coupled boost half-bridge converter is used to harness power from wind, while bidirectional buck-boost converter is used to harness power from PV along with battery charging/discharging control. A single-phase full-bridge bidirectional converter is used for feeding ac loads and interaction with grid. The proposed converter architecture has reduced number of power conversion stages with less component count, and reduced losses compared to existing grid-connected hybrid systems. Then we are going to test the single phase multilevel converter to feed ac loads and interaction with grid.

Keywords: PV wind, Grid, Bi Directional DC-DC Converter .

I. INTRODUCTION

Fast consumption of fossil fuel holds, results in expanding vitality request and concerns over environmental change persuade control power generation from renewable energy sources. Sunlight based photovoltaic (PV) and wind have risen as well known vitality sources due to their eco-friendly nature and cost adequacy.

Nonetheless, these sources are irregular in nature. Consequently, it is a test to supply steady and consistent power utilizing these sources. This can be tended to by proficiently coordinating with energy storage components. The interesting correlative conduct of sun powered insolation and wind speed pattern combined has led to the exploration on their combination bringing about the hybrid PV-wind frameworks. For accomplishing the reconciliation of numerous renewable sources, the customary approach includes utilizing devoted single-input converters one for each source, which are associated with a typical dc-link. Be that as it may, these converters are not successfully used, because of the discontinuous way of the renewable sources. Moreover, there are numerous power transformation stages which decrease the proficiency of the framework.

Hybrid PV-wind based system of power and their interfaces with the power network are the imperative research territories. Proposed multi-input half breed PV-wind control generation framework which has a buck/buck-help combined multi-input dc-dc converter and a full-connect ac inverter. This system is essentially centered around enhancing the dc-interface voltage direction.

The utilization of multi-input converter (MIC) for cross breed control frameworks is pulling in expanding consideration on account of decreased part number, upgraded control thickness, smallness and concentrated control. Because of these favorable conditions, numerous topologies are proposed and they can be characterized into three gatherings, non-detached, completely segregated and halfway disengaged multi-port topologies.

All the state of the art on converter topologies presented so far can oblige just a single renewable source and one energy storage element. Though, the proposed topology is fit for interfacing two renewable sources and a energy storage element. Consequently, it is more solid as two distinct sorts of renewable sources like PV and wind are utilized either separately or at the same time without increment in the segment tally contrasted with the existing state edge topologies.

The proposed framework has two renewable power sources, load, lattice and battery. Subsequently, a power flow management system is basic to adjust the power flow among every one of these sources. The primary goals of this framework are as per the following:

- To investigate a multi-object control scheme for optimal charging of the battery utilizing numerous sources.

- Supplying un-interruptible energy to loads.
- Ensuring departure of surplus power from renewable sources to the network, and charging the battery from framework as and when required.

The network associated half breed PV-wind-battery based framework for family unit applications which can work either in remain solitary or grid associated mode. This framework is reasonable for family unit applications, where an ease, basic and reduced topology equipped for independent operation is attractive. The center of the proposed framework is the multi input transformer coupled bidirectional dc-dc converter that interconnects different power sources and the capacity component.

II. PROPOSED CONVERTER CONFIGURATION

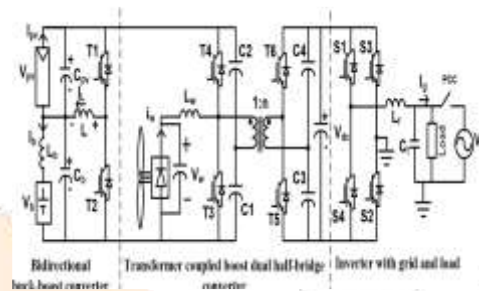

Fig.1 Proposed converter configuration

The proposed converter comprises of a transformer coupled boost double half-bridge bidirectional converter fused with bidirectional buck-boost converter and a solitary stage full-connect inverter. The proposed converter has decreased number of power transformation stages with less part check and high productivity contrasted with the existing grid associated plans. The topology is straightforward and needs just six power switches. The schematic graph of the converter is delineated in Fig.1. The boost double half-bridge converter has two dc-interfaces on both sides of the high recurrence transformer. Controlling the voltage of one of the dc-link, guarantees controlling the voltage of the other. This makes the control procedure basic. Besides, extra converters can be incorporated with any of the two dc-joins. A bidirectional buck-help dc-dc converter is coordinated with the essential side dc-connection and single-stage full scaffold bidirectional converter is associated with the dc-connection of the auxiliary side.

The contribution of the half-bridge converter is designed by associating the PV exhibit in arrangement with the battery, accordingly incorporating an inherent boosting stage for the scheme. The boosting capacity is further improved by a high frequency step-up transformer. The transformer likewise guarantees galvanic segregation to the heap from the sources and the battery. Bidirectional buck help converter is utilized to bridle control from PV alongside battery charging/releasing control. The one of a kind element of this converter is that MPP following, battery charge control and voltage boosting are refined through a solitary converter. Transformer coupled boost half-bridge converter is utilized for harnessing power from wind and a solitary stage full-connect bidirectional converter is utilized for sustaining air conditioning burdens and association with framework. The proposed converter has diminished number of force change stages with less segment tally and high proficiency contrasted with the current network associated converters.

The power flow of wind source is controlled through a unidirectional boost half-bridge converter. For acquiring MPP successfully, smooth variety in source current is required which can be gotten utilizing an inductor.

In the proposed topology, an inductor is put in arrangement with the wind source which guarantees constant current and accordingly this inductor current can be utilized for keeping up MPP current.

During the ON time of T 3, the primary voltage $V_P = -VC1$. The secondary voltage $V_S = nV_p = -nVC1 = -VC3$, or $VC3 = nVC1$ and voltage across primary inductor L_w is V_w . When T 3 is turned OFF and T 4 turned ON, the primary voltage $V_P = VC2$. Secondary voltage $V_S = nV_p = nVC2 = VC4$ and voltage across primary inductor L_w is $V_w - (VC1 + VC2)$. It can be proved that

$$(VC1 + VC2) = \frac{V_w}{(1-D_w)}$$

The capacitor voltages are considered constant in steady state and they settle at $VC3 = nVC1$, $VC4 = nVC2$. Hence the output voltage is given by

$$V_{dc} = VC3 + VC4 = n \frac{V_w}{(1-D_w)} \quad \dots (1)$$

In this manner, the yield voltage of the auxiliary side dc-connection is an element of the obligation cycle of the essential side converter and turns proportion of transformer.

In the proposed design as appeared in Fig. 2(a), a bidirectional buck-support converter is utilized for MPP following of PV exhibit and battery charging/releasing control. Promote, this bidirectional buck-support converter charges/releases the capacitor bank C1-C2 of transformer coupled half-connect help converter in view of the heap request. The half-connect help converter extricates vitality from the twist source to the capacitor bank C1-C2. Amid battery charging mode, when switch T 1 is ON, the vitality is put away in the inductor L. At the point when switch T 1 is killed and T 2 is turned ON, vitality put away in L is exchanged to the battery. On the off chance that the battery releasing current is more than the PV current, inductor current gets to be distinctly negative.

Here, the stored energy in the inductor increases when T 2 is turned on and decreases when T 1 is turned on. It can be proved that $V_b = \frac{D}{1-D} V_{PV}$. The output voltage of the transformer coupled boost half-bridge converter is given by,

$$V_{dc} = n(V_{C1} + V_{C2}) = n(V_b + V_{PV}) = \frac{nV_w}{1-D_w} \quad \dots (2)$$

This voltage is n times of primary side dc-link voltage. The primary side dc-link voltage can be controlled by half-bridge boost converter or by bidirectional buck-boost converter. The relationship between the average value of inductor, PV and battery current over a switching cycle is given by $I_L = I_b + I_{pv}$. It is evident that, I_b and I_{pv} can be controlled by controlling I_L . Therefore, the MPP operation is assured by controlling I_L while maintaining proper battery charge level. I_L is used as inner loop control parameter for faster dynamic response while for outer loop, capacitor voltage across PV source is used for ensuring MPP voltage. An incremental conductance method is used for MPPT.

A. Limitations and Design issues

The output voltage V_{dc} of transformer coupled boost dual half-bridge converter, depends on MPP voltage of PV array V_{PV} , the battery voltage V_b and the transformer turns ratio n.

III. PROPOSED CONTROL SCHEME FOR POWER FLOW MANAGEMENT

A lattice associated half and half PV-wind-battery based framework comprising of four power sources (grid, PV, wind source and battery) and three power sinks (network, battery and load), requires a control conspire for power flow management to adjust the power flow among these sources. The control reasoning for power flow management of the multi-source framework is produced in view of the power adjust standard. In the remain solitary case, PV and wind source produce their comparing MPP power and load takes the required power. For this situation, the power adjust is accomplished by charging the battery until it achieves its greatest charging current farthest point I_{bmax} . After achieving this farthest point, to guarantee control adjust, one of the sources or both need to go astray from their MPP control in view of the heap request. In the lattice associated framework both the sources dependably work at their MPP. Without both the sources, the power is attracted from the lattice to charge the battery as and when required. The condition for the power management of the system is given by:

$$V_{PV}I_{PV} + V_WI_W = V_bI_b + V_gI_g \quad \dots (3)$$

The peak value of the output voltage for a single-phase full bridge inverter is,

$$\hat{V} = m_a V_{dc} \quad \dots (4)$$

and the dc-link voltage is,

$$V_{dc} = n (V_{pv} + V_b) \quad \dots (5)$$

Hence, by substituting for V_{dc} in (4), gives,

$$V_g = \frac{1}{\sqrt{2}} m_a n (V_{pv} + V_b) \quad \dots (6)$$

In the boost half-bridge converter,

$$V_w = (1 - D_w)(V_{pv} + V_b) \quad \dots (7)$$

Now substituting V_w and V_g in (3),

$$V_{PV}I_{PV} + (V_{pv} + V_b)(1 - D_w)I_w = V_bI_b + \frac{1}{\sqrt{2}} m_a n (V_{pv} + V_b)I_g \quad \dots (8)$$

After simplification,

$$I_b = I_{pv} \left(\frac{1-D_{pv}}{D_{pv}} \right) + I_w \left(\frac{1-D_w}{D_{pv}} \right) - I_g \left(\frac{m_a n}{\sqrt{2} D_{pv}} \right) \quad \dots (9)$$

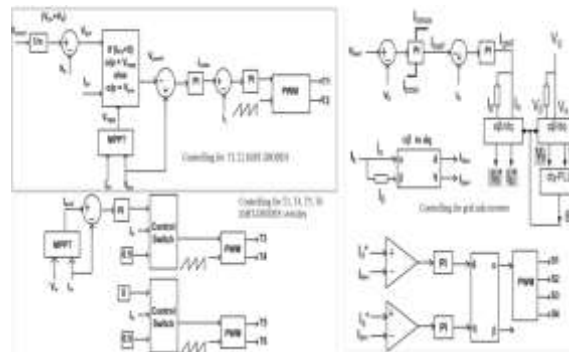

Fig.2: controlling for circuit shown in fig.1

from the above conditions it is obvious that, if there is an adjustment in power decreases from either PV or wind source, the battery current can be directed by controlling the lattice current I_g . Thus, the control of a solitary stage full-connect bidirectional converter relies on upon accessibility of network, power from PV and wind sources and battery charge status. Its control procedure is delineated utilizing Fig. 3. To guarantee the supply of continuous energy to basic burdens, need is given to charge the batteries. In the wake of achieving the most extreme battery charging current point of confinement I_{bmax} , the surplus power from renewable sources is bolstered to the grid. Without these sources, battery is charged from the framework.

IV. SIMULATION RESULTS

The steady state response of the system during the MPPTmode of operation is shown in Fig. 3. The values for source-1 (PV source) is set at 35.4 V (V_{mpp}) and 14.8 A (I_{mpp}),and for source-2 (wind source) is set at 37.5 V (V_{mpp}) and 8 A (I_{mpp}). It can be seen that V_{pv} and I_{pv} of source-1,and V_w and I_w of source-2 attain set values required for MPPOperation. The battery is charged with the constant magnitudeof current and remaining power is fed to the grid. The system response for step changes in the source-1insolation level while operating in MPPT mode is shown inFig. 5. Until 2 s, both the sources are operating at MPPT andcharging the battery with constant current and the remainingpower is fed to the grid. At instant 2 s, the source-1 insolationlevel is increased. As a result the source-1 power increases

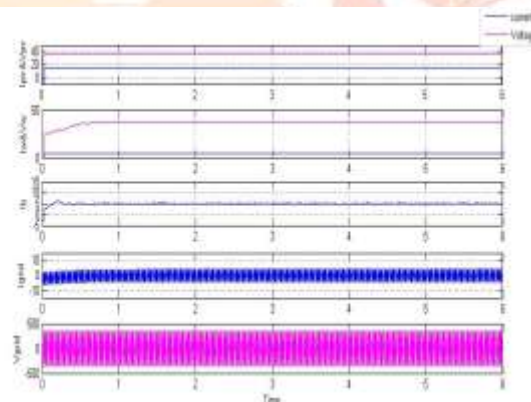

Fig.3: I_{pv} and V_{pv} , I_w and V_w , I_b , I_{grid} and V_{grid} when both PV and wind sources are active

and both the sources continue to operate at MPPT. Though the source-1 power has increased, the battery is still charged with the same magnitude of current and power balance is achieved by increasing the power supplied to the grid. At instant 4 s, insolation of source-1 is brought to the same level as before 2s. The power supplied by source-1 decreases. Battery continues to get charged at the same magnitude of current, and power injected into the grid decreases. The same results are obtained for step changes in source-2 wind speed level

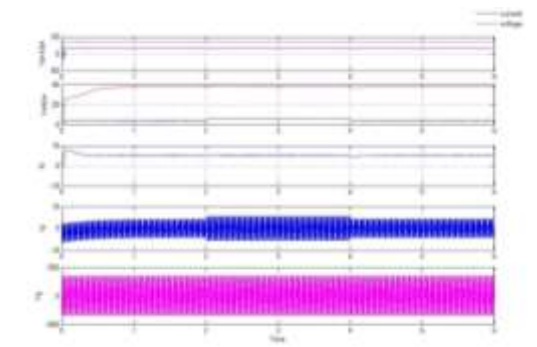

Fig.4: Ipv and Vpv, Iw and Vw, Ib, Igrid and VgridWhen wind sources increases

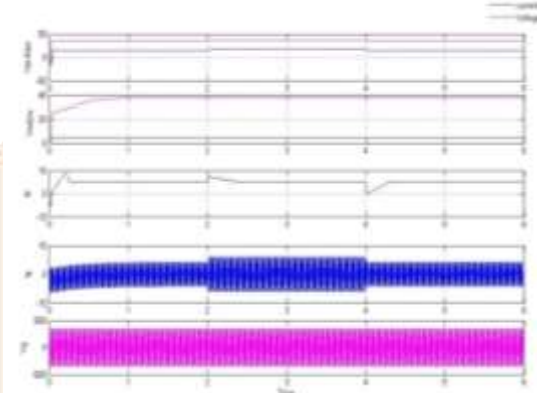

Fig.5: Ipv and Vpv, Iw and Vw, Ib, Igrid and VgridWhen PV sources increases

By connecting a multi level inverter we know the harmonics are going to decrease and that can be used in grid current and voltage. In this we are used a single phase diode clamped multilevel inverter on the grid side.

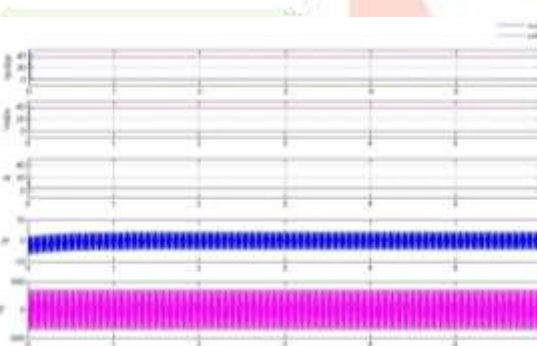

Fig. 6: pv and Vpv, Iw and Vw, Ib, Igrid and VgridWhen both PV and wind sources are inactive

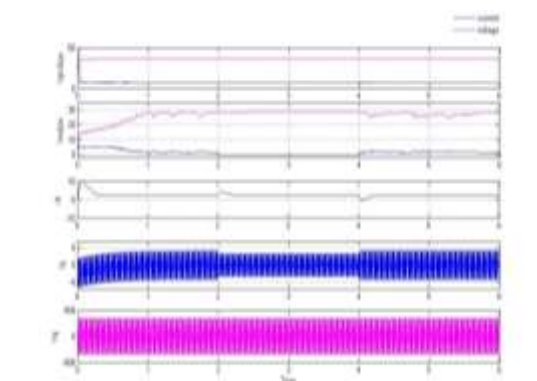

Fig.7: Ipv and Vpv, Iw and Vw, Ib, Igrid and VgridWhen wind sources decreases suddenly

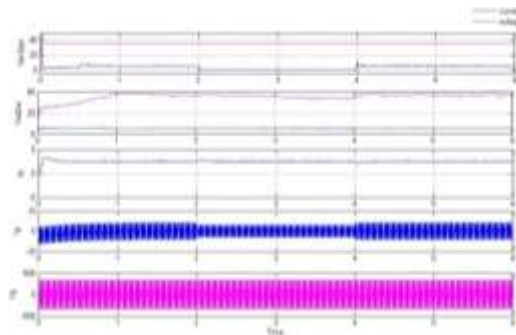

Fig.8:Ipv and Vpv, Iw and Vw, Ib, Igrid and VgridWhen PV sources decreases suddenly.

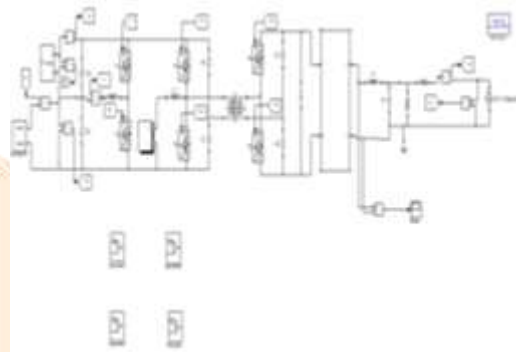

Fig.9: Simulation model for grid connected pv wind battery with multilevel inverter

We can observe it in below table

Table.1 Comparison of results

	Ig	Vg
Base	0.81%	0.10%
ext	0.08%	0.09%

V. CONCLUSION

The proposed hybrid system provides an elegant integration of PV and wind source to extract maximum energy from the two sources. It is realized by a novel multi-input transformer coupled bidirectional dc-dc converter followed by a conventional full-bridge inverter. A versatile control strategy which achieves better utilization of PV, wind power, battery capacities without effecting life of battery and power flow management in a grid-connected hybrid PV-wind-battery based system feeding ac loads is presented. Detailed simulation studies are carried out to ascertain the viability of the scheme, by placing multilevel inverter we observe the improvement.

REFERENCES

[1] F.Valenciaga and P. F. Puleston, "Supervisor control for a stand-alone hybrid generation system using wind and photovoltaic energy," IEEETrans. Energy Convers., vol. 20, no. 2, pp. 398-405, Jun. 2005.

[2] C. Liu, K. T. Chau and X. Zhang,"An efficient wind-photovoltaic hybrid generation system using doubly excited permanent-magnet brushless machine,"IEEE Trans. Ind. Electron., vol. 57, no. 3, pp. 831-839, Mar.2010.

[3] W. Qi, J. Liu, X. Chen, and P. D. Christofides, "Supervisory predictive control of standalone wind/solar energy generation systems," IEEETrans. Control Sys. Tech., vol. 19, no. 1, pp. 199-207, Jan. 2011.

[4] F. Giraud and Z. M. Salameh, "Steady-state performance of a grid connected rooftop hybrid wind-photovoltaic power system with battery storage," IEEE Trans. Energy Convers., vol. 16, no. 1, pp. 1-7, Mar.2001.

[5] S. K. Kim, J. H. Jeon, C. H. Cho, J. B. Ahn, and S. H. Kwon,"Dynamic modeling and control of a grid-connected hybrid generation system with versatile power transfer,"IEEE Trans. Ind. Electron., vol. 55, no. 4, pp.1677-1688, Apr. 2008.

[6] M. Dali, J. Belhadj and X. Roboam,"Hybrid solar-wind system with battery storage operating in grid-connected and standalone mode: control and energy management-experimental investigation," Energy, vol.35, no. 6, pp. 2587-2595, June 2010.

gust,"IEEE Trans. Energy Convers., vol. 12, no. 1, pp. 73-78, Mar. 1997.

Author's Profile:



ARETI. GOPI received currently he is pursuing her Master Degree in the department of Electrical & Electronic Engineering: Nova College of Engineering & Technology, Jupudi, and Andhra Pradesh, India.

Email: aretigopi@gmail.com

