

# AUTOMATIC IRRIGATION AND MOTION DETECTION USING IOT

<sup>1</sup>P.CHITRA, <sup>2</sup>MAGENDRAN.A, <sup>3</sup>MAGESH.S, <sup>4</sup>RAJA.D

<sup>1</sup>PROFESSOR.

<sup>2,3,4</sup>STUDENT.

<sup>1</sup>PRATHYUSHA ENGINEERING COLLEGE, CHENNAI, INDIA.

## ABSTRACT:

Water scarcity and field monitoring are big concern at recent times. This project is used to irrigate the farmland and also protect the field from trespassers. In an efficient manner with an automated irrigation system based on a water capacity needed for a particular plant will be irrigated. Soil moisture sensor is used to find moisture level in the field and based on this a periodic notification is displayed to the farmer and the system will automatically switching the console of the motor pump. For field monitoring a motion sensor is used. During trespassing, a notification is passed to the farmer and he can control his farming field.

**KEYWORDS:** PIR sensor, Soil Moisture sensor, Water level sensor, Gas sensor, GSM module.

## I. INTRODUCTION:

India consist of a vast land in North the Himalayas in West the Thar in East the Sutherland and other deep forest and in South the Deccan. More often we lived in a moderate climate because of the natural protection of this land. For 1.25 billion people live in this land it provides food by agriculture and agricultural products provided by farmers and hence they provide probably more than our needs and it is recently reducing due to their wages which is constantly reducing year by year. The lack of investment and turn down in man power gives less result which affects their livelihood hardly. In this project we were excluding the manpower of the farmers by giving a product with work free and provides field protection to avoid the animal inclusion or presence in the field. This will reduces the presence of the farmer in the field for irrigation process which will automatically done by the system which makes to earn through other ways for his livelihood.

## II. ARCHITECTURAL DIAGRAM:

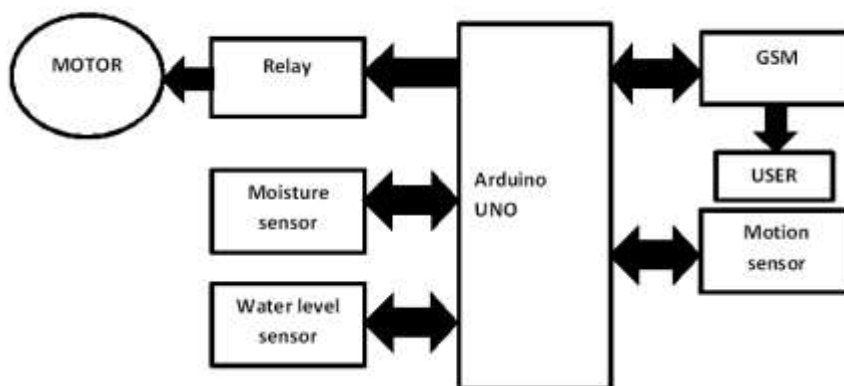

The main component of this project is arduino, which acts as backbone to connect the sensors and other modules for integration. First, the soil moisture sensor collects the data from the soil and passes it to the arduino. Water will be irrigated (or) stopped as per the threshold value get by the sensor. The message will be passed to the farmer by the result of the sensor. During irrigation when the level of the water gets maximum, level of water indicator (or) sensor passes the information to the arduino and the flow of water from

the pump will be stopped. The message will be passed from the GSM module to the farmer (or) user. In the meanwhile, the farm field will be monitored 24x7 by using motion detection sensor. When any animal (or) human passes into the field the sensor detects and passes the value to the arduino. Then the message will be passed to the farmer (or) user by using GSM.

### III. HARDWARE DESIGN:

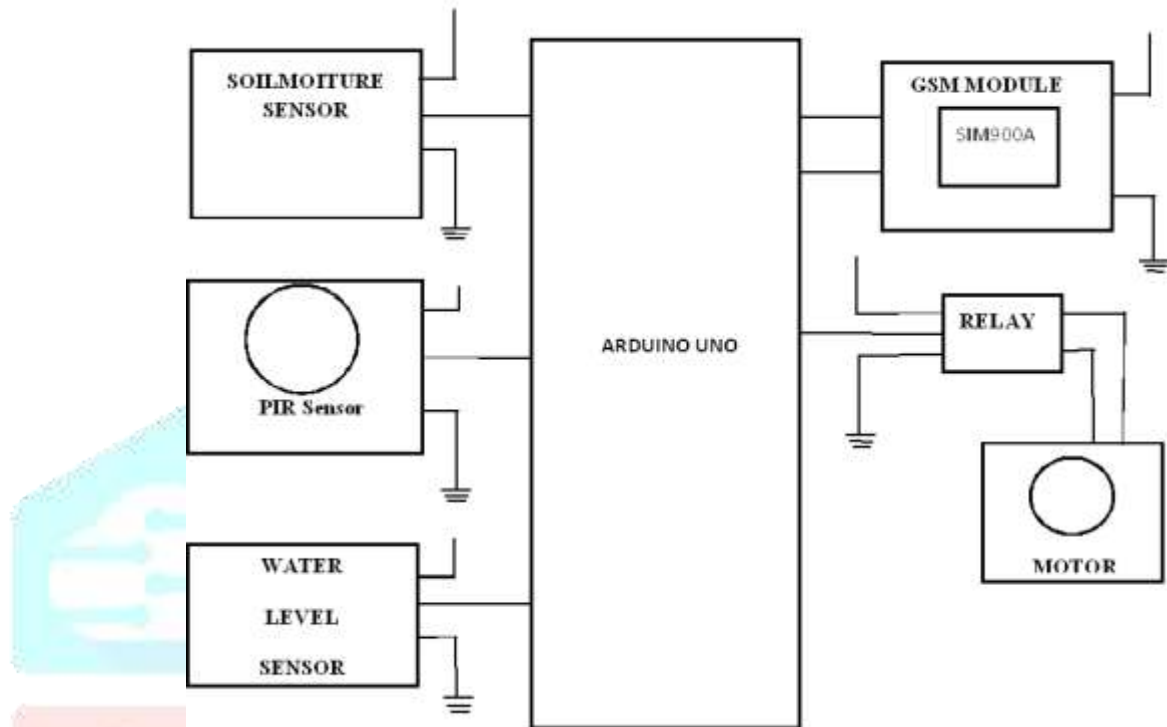

### IV. MODULE DESCRIPTION:

#### GSM:

GSM stands for global system for mobile communication as like the expansion . it is a class of wireless modem devices that is used for communication. This module is used for transmitting messages from arduino board to mobile phone. It requires SIM card for communicating with devices using the network. The GSM module also contains IMEI number for their identification like smart phones. The GSM also contains some interesting features like sending and deleting normal messages, searching adding or removing entries in a SIM and creating or rejecting a voice call. The GSM requires user commands for processing as codes which are implemented in the controller. The power supply also present in the GSM module which is used for activating/switching ON the module.

#### SOIL MOISTURE SENSOR:

The soil moisture sensor works on the circuit type connection when the soil is dry there will be no closed circuit and there will be no flow of current present in the soil. So, the threshold value present in the soil will be low. When the soil moisture sensor kept in a wet soil then there will be a closed circuit then the current passes will be high. So, the threshold value of the soil will be high. The threshold value changes according to the nature of the soil that are to be detected. The value to be identified and the flow of water to be given by the arduino automatically.

#### PIR SENSOR:

Passive infrared sensor is used in many systems like security systems detection of motion system or detecting trespassing modules thus sensor named as it absorbs infrared radiation not emits it also detects any changes in heat when there is a body passing

through the sensor the infrared emits from the body when there is a friction between the air and the human body that are to be released the main component of the PIR sensor HC-SR501 sensor which collects the data from the wide range and helps in detecting human intervention the sensor connected with a plastic cap like cover which consist of Fresnel lens which makes the sensor to cover a maximum range .The sensor consist of BISS0001 IC which is connected with various resistors and capacitors which involving in reading input and output data as high or low.

#### **WATER LEVEL SENSOR:**

Water level measure is to find the level of water in the particular place (or) measure from dig. This sensor actually works from the resistance value which is collected from the sensor.The sensor which is to be closed due to duplicate reading appears through rain fall. If the threshold value will high which means that the water level is high and vice-versa.

#### **V. LITERATURE REVIEW:**

- [1]P.Rajalakshmi,S.Devi Mahalakshmi has proposed the method the arduino is used for irrigating and for monitoring purpose this method is used for maintaining plant in a garden for irrigation purposes for the plants by using internet of things.
- [2]Y.Kim,RG.Evans,WM.Iversen has method used cloud for passing information to the user this method is to sense the plant from distant location to maintain the field.
- [3]J.Gutierrez,JF.Billa-neeina has method uses GPRS module for passing messages to the user the range of connectivity is good but instead of a stable connectivity is required the module automated by means of irrigation purposes only.
- [4]N.Wang, N.Zhang and M.Wang has method is used as a perspective method for using sensors in development in agro industrial purposes which is developed recently it is not an implementation or practical practices.
- [5]Joaquin Gutierrez,Juan Francisco Villa-Medina,Alejandra Nieto-Garibay,Miguel Angel Porta-Gandara has module automated irrigation system is done using arduino using a wireless network which is connected through GPRS module
- [6]PandurangH.Tarange,RajanG.Mevekari,Prashant A.Shinde has proposed a system which is embedded with a linux board it is linked with a wireless sensor board for passing information to the user
- [7]Zhang and Feng has proposed the system using the arduino. This is used as a water conservation as the process is completely automated for irrigation this process does not involved with the conservation control.
- [8]Sonal Verma ,Nikhil Chug and Dhananjay V. Gadre has proposed a system for field monitoring purpose this process as not as efficient as other system due to high field monitoring.
- [9]B. Balaji Bhanu, K. Raghava Rao, J.V.N. Ramesh and Mohammed Ali Hussain has proposed a system for analysis as field monitoring which is used as wireless sensor for improving the agriculture field.
- [10]G. Nisha and J. Megala has proposed the system which is used for irrigation and also protect field from trespassing and sends the information using wireless sensor.
- [11]KazuyaKanda, Tadashi Ishii ,Takaharu\_Kameoka,Kouhei\_Saitoh and\_Ryousuke\_Sugano has proposed a system which is connected to the agro server for field monitoring this tracks the location of the field for monitoring purposes.
- [12]Farhad Mehdipour , has implemented for smart field monitoring it is an advanced level processingsystem and its works still stands on for research and other advanced farming researches

[13]Jzau-Sheng Lin and Chun-Zu Liu has proposed this system based on system on a chip platform for precision monitoring in agricultural lands which is automated through a wireless sensor

[14]K.Nirmal Kumar, P.Ranjith and R. Prabakaran has proposed a system using Zig-Bee networks which is a low level communication area for paddy crop management and monitoring purpose this is a regional low level communication area for the farmers.

[15]S. R. Prathibha and Anupama Hongal has proposed a system using IOT devices for monitoring using GSM they passing Information to the farmers

## VI. PROPOSED METHOD:

The soil moisture sensor which collects the moisture level of the soil and passes it to the arduino then, the pump works according to the level of moisture content in the soil. The water level rises in the field when it attains the threshold which is measured from water level sensor the motor immediately stops. In the meanwhile, the gas sensor will identify the value of gas present in the air and the motion level sensor will track(or)monitor whether there is any unwanted motion is present around the field.This value will be monitored and notifications will be passed t other farmer using GSM module to the farmer.

## ADVANTAGES:

- It is environment friendly.
- It avoid human intervention in the farm land by monitoring the field hence it is helps in trespassing the field..
- It increases in supplying water at regular intervals providing in surface runoff water in the field.
- The conservation of water it maintained.

## VII. CONCLUSION:

Thus this paper shows how the researches are held on maintaining a safe, clean and automated environment which will evolve in future preservation of the human evolution. The transformation is rapidly changing day-by-day and we need to cope up with the environment. This method is completely automated for irrigation and monitoring and also to check the gas level of the air at constant intervals and passes these information periodically to the user with accuracy to help the farmer for an advanced irrigation method.

## VIII. REFERENCE:

[1]IOT based crop-field monitoring and irrigation automation [ieeexplore.ieee.org/document/7726900/]

[2]Remote sensing and control of irrigation system using a distributor wireless sensor network.[https://pdfs.semanticscholar.org/8075/c73fd8b13fa9663230a383f5712bf210ebcf.pdf]

[3]Automated irrigation system using a wireless sensor using GPRS module. 2014[ieeexplore.ieee.org/document/6582678/]

[4]wireless sensor in agriculture and food industry-recent development and future perspective.[https://www.sciencedirect.com/science/article/pii/S0168169905001572]

[5]Automated Irrigation System Using a Wireless Sensor Network and GPRS Module [ieeexplore.ieee.org/document/6582678/]

[6]Webbased automatic irrigation system using wireless sensor network and embedded Linux board[ieeexplore.ieee.org/document/7159327/]

[7]Research on water-saving irrigation automatic control system based on internet of things.[ieeexplore.ieee.org/document/5778297/]

- [8]Wireless Sensor Network for Crop Field Monitoring.2010[ieeexplore.ieee.org/document/5460537/]
- [9]Agriculture field monitoring and analysis using WSN for improving crop production[ieeexplore.ieee.org/document/6923043/]
- [10]Wireless sensor Network based automated irrigation and crop field monitoring system [ieeexplore.ieee.org/document/7229707/]
- [11]Field monitoring system using Agri-Server[ieeexplore.ieee.org/document/6060312/]
- [12]Smart Field Monitoring: An Application of Cyber-Physical Systems in Agriculture [ieeexplore.ieee.org/document/6913290/]
- [13]A monitoring system based on wireless sensor network and an Soc platform in precision agriculture[ieeexplore.ieee.org/document/4716133/]
- [14]Real time paddy crop field monitoring using Zig-Bee network.[ieeexplore.ieee.org/document/5760290/]
- [15]IOT Based Monitoring System in Smart Agriculture.2017[ieeexplore.ieee.org/document/8081906/]

