

ANALYSIS OF CAM SHAFT FOR DIFFERENT MATERIALS

Dr.V.Jayaseelan¹, Dr.P.Jayaraman², R.Saravanan³, V.Shanmugam⁴, T.R.Priyanka⁵

Professor^{1,2}

Department of Mechanical Engineering

Prathyusha Engineering College, Thiruvallur, Chennai India-602025

Abstract: In an internal combustion engine camshaft is used to control the injection of vaporized fuel. These are occasionally confused with the crankshaft of the engine, where the reciprocating motion of the piston is converted into rotational energy. The different types of materials can be used to make the engine cam shaft. The materials used in the camshaft depend upon the quality and type of engine being manufactured. For most mass-produced automobiles, chilled cast iron is used. This undergoing process increasing its strength and hardness due to cold treating. In this project, a cam shaft will be designed for a 150cc engine and modelled through CATIA. Present used material for camshaft is cast iron. In this work, the camshaft material will be replaced with steel and aluminium alloy. Cast iron, Steel and Aluminium alloy are used in cam shaft for the structural and model analysis. Comparison will be done for the three materials to verify the better material for camshaft. Modelling is done using CATIA software and analysis carried out by ANSYS

1. INTRODUCTION

A cam is used to transmit motion to a follower. The driver is called the cam and the driven member is called the follower. In a cam follower pair, the cam normally rotates while the follower may translate or oscillate. Cam is used for transmitting a desired motion to a follower by direct contact. This mechanism is a case of a higher pair with line contact. Camshaft is the Brain of the engine. It includes cam lobes, bearing journals, and a thrust face to prevent fore and after motion of the camshaft. To drive a fuel pump it includes a gear to drive the distributor and an eccentric. Camshaft is controlling the valve train operation. The firing order is determined by the camshaft along with the crank shaft. Camshaft is along with the suction and exhaust systems it determines the useful rpm range of the engine. Camshaft is used for transferring motion from inlet and outlet valve. If transfer of motion is not proper then the stokes will not work in proper way. It is required in order to design a good mechanism linkage, the dynamic behaviour of the components must be considered; This includes the gross kinematic motion and self-induced vibration motion. For manufacturing the Dynamic models were created to obtain insight into dynamic behaviour of the system. The mathematical tools were used to simulate and predict the behaviour of physical systems. They contain systems properties which are masses, stiffness constants, and damping coefficients. The automotive sector has reached a very high production capacity in the last decades. Depending on this increasing capacity, its stable growth is anticipated in the word economy. With the four-stroke cycle engine, the cycle of events of the inlet and exhaust valve opening and closing is performed by the camshaft in one revolution, but the piston strokes (induction, compression, power, and exhaust) are completed in two crankshaft revolutions. Consequently, for the camshaft timing cycle to be in phase with the crankshaft angular movement, the camshaft has to turn at half crankshaft speed, that is, a 2:1 speed ratio. The crankshaft to camshaft drive may be transmitted by three different methods: chain, belt, or gear. There are several types of camshaft arrangement including cylinder block mounted camshaft, OHC with injection pump drive for diesel engines, twin OHC drive for gasoline engines, The camshafts are generally produced by casting or forging. The cast camshafts are made from modular cast iron. The cam surfaces and journal surfaces are heat treated to obtain hard surfaces.

2. DESIGN AND MODELLING

Alloy steels are steels containing elements such as chromium, cobalt, nickel, etc. Alloy steels comprise a wide range of steels having compositions that exceed the limitations of Si, Va, Cr, Ni, Mo, Mn, B and C allocated for carbon steels. In this work Steel 157.19 0.0056878, Chilled cast iron 157.5 0.0104, Structural aluminum are considered as input materials for analysis.

3. FINITE ELEMENT ANALYSIS

The method yield approximate values of the unknowns at discrete number of points over the field. To solve, it subdivides a large problem into smaller, simpler parts that are called finite elements. The entire problem is modelled by the simple equation in which these finite elements are then assembled into a larger system of equations. To approximate the solution in FEM then uses variational

methods from the calculus of variations by minimizing an associated error function. FEA is used for analyzing problems over complicated domains, when the domain changes, when the desired precision varies over the entire domain, or when the solution lacks smoothness. FEA simulations provide a valuable resource as they remove multiple instances of creation and testing of hard prototypes for various high fidelity situations. From this analysis VON-MISES STRESS and DEFORMATION are analyzed for the different material. Input values are shown in the table 1.

Table 1. Input values for cam shaft design

| Materials | Young's modulus (pa) | Poisson's ratio | Bulk modulus (Pa) | Shear modulus (Pa) |
|------------------------------|----------------------|-----------------|------------------------|------------------------|
| Cast iron 157.190.0056878 | 1.3e ⁰¹¹ | 0.3 | 1.0833e ⁰¹¹ | 5.e ⁰¹⁰ |
| Steel 157.5 0.01043 | 2.8e ⁰⁰⁸ | 0.3 | 2.3333e ⁰⁰⁸ | 1.0769e ⁰⁰⁸ |
| Aluminium | 6.9e ⁰¹⁰ | 0.32 | 6.3889e ⁰¹⁰ | 2.6136e ⁰¹⁰ |

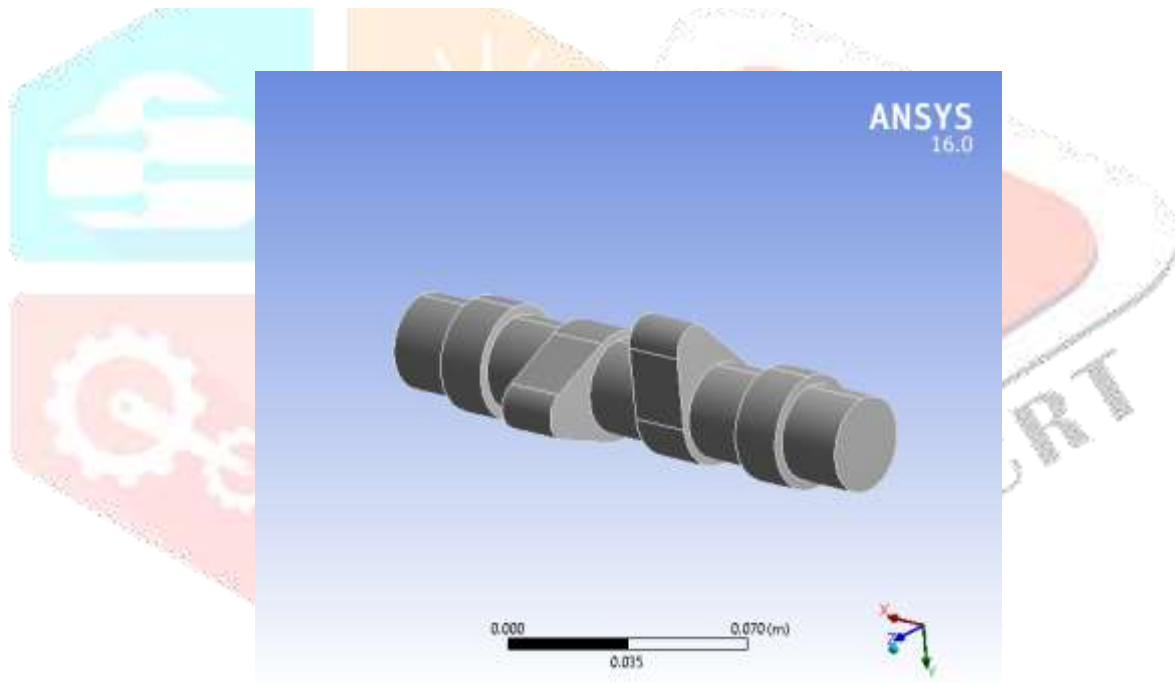

Fig 1.Camshaft design

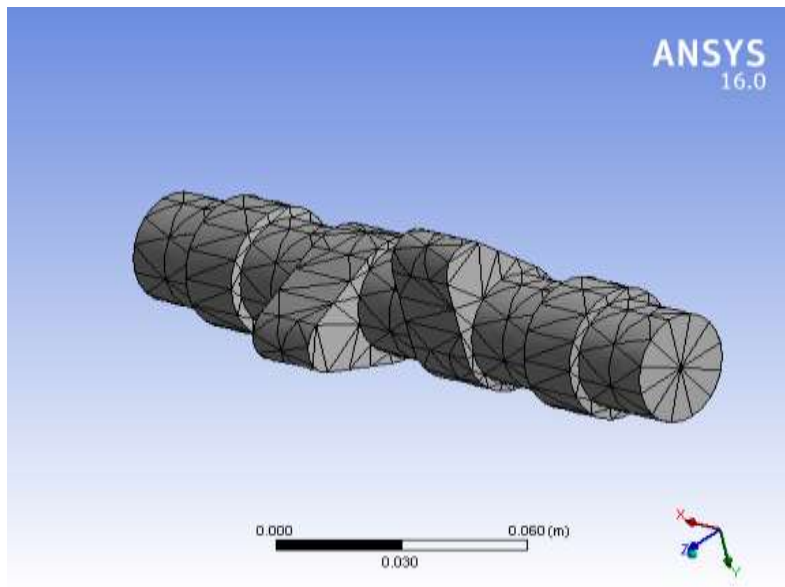

Fig 2. Meshed model

4. RESULTS AND DISCUSSION

4.1 Analysis of Aluminium

Modal analysis of camshaft is carried out. As per analytical solution deflection of camshaft was Maximum bending stress is 20.98MPa and from analytical solution it is 19.483MPa. From the analyzed results and the design is safe.

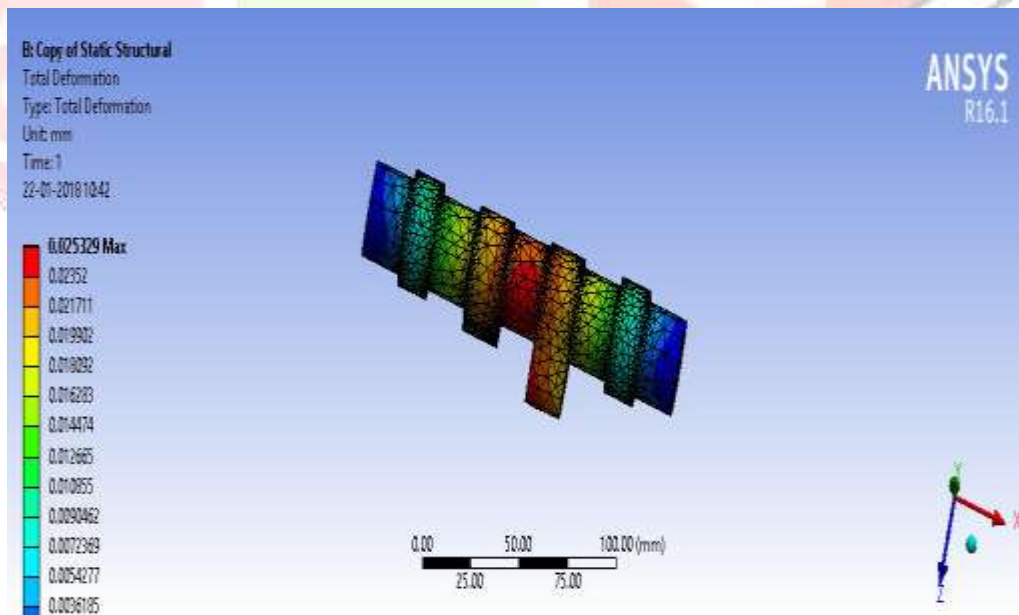

Fig 3. Total deformation of Aluminium

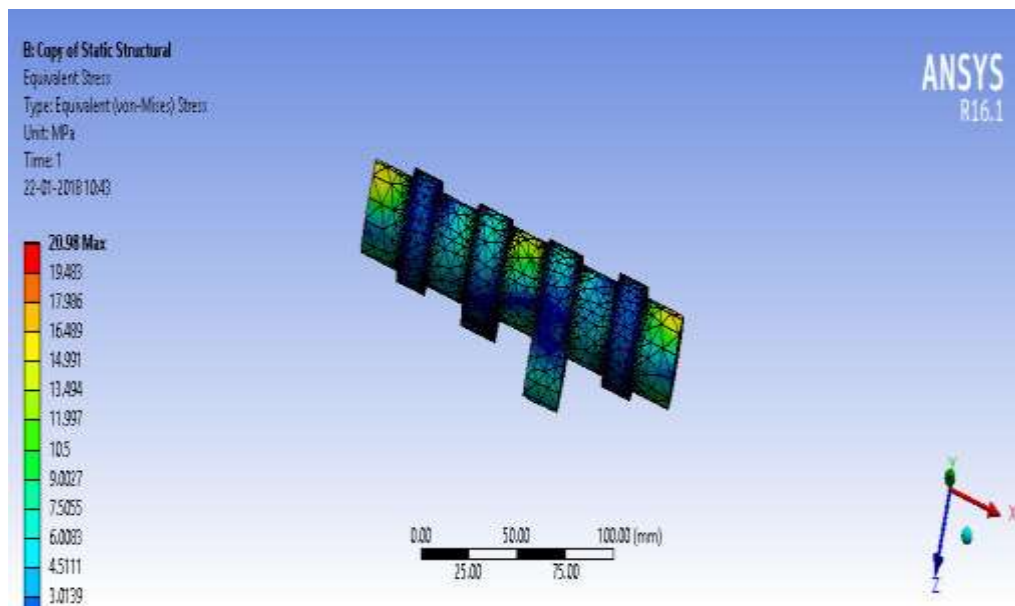

Fig4.Stress analysis

4.2 Analysis of cast iron

Modal analysis of camshaft is carried out. As per analytical solution deflection of camshaft was Maximum bending stress is 11.302 MPa and from analytical solution it is 10.276 MPa. From the analyzed results and the design is safe

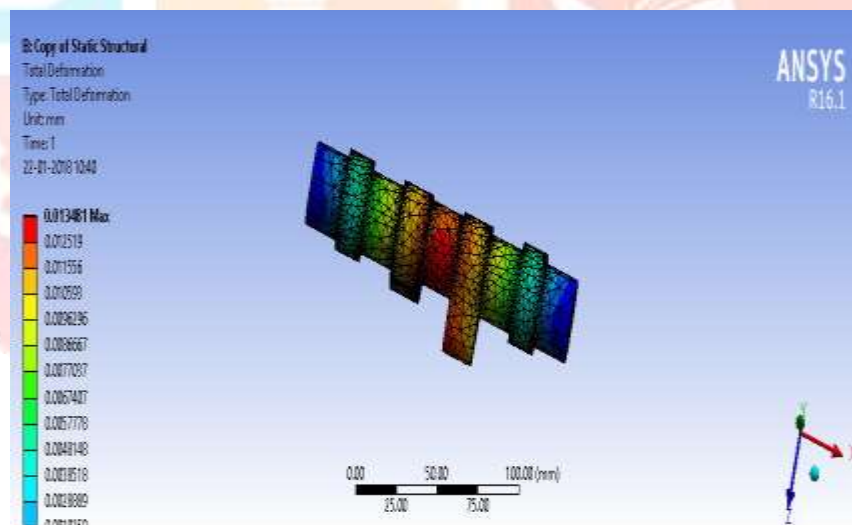

Fig5. Total Deformation

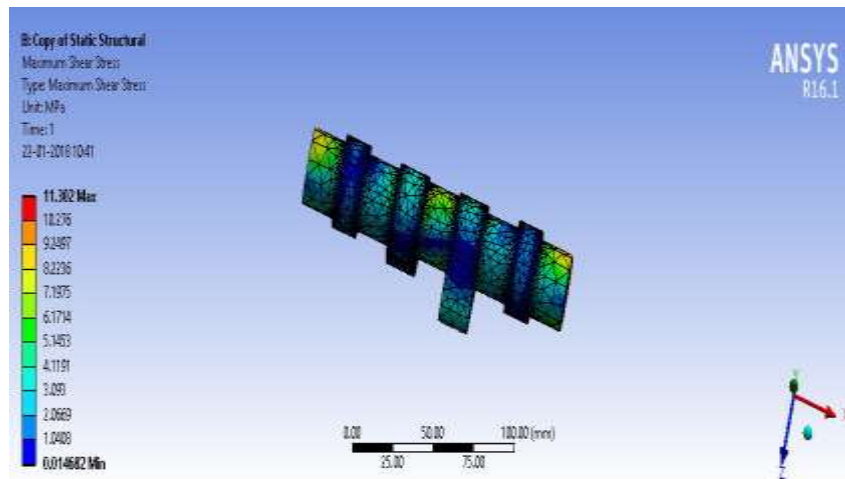

Fig6.Stress analysis

4.3 Analysis of steel

As per analytical solution deflection of camshaft was Maximum bending stress is 21.285MPa and from analytical solution it is 18.628MPa. From the analyzed results and the design is safe

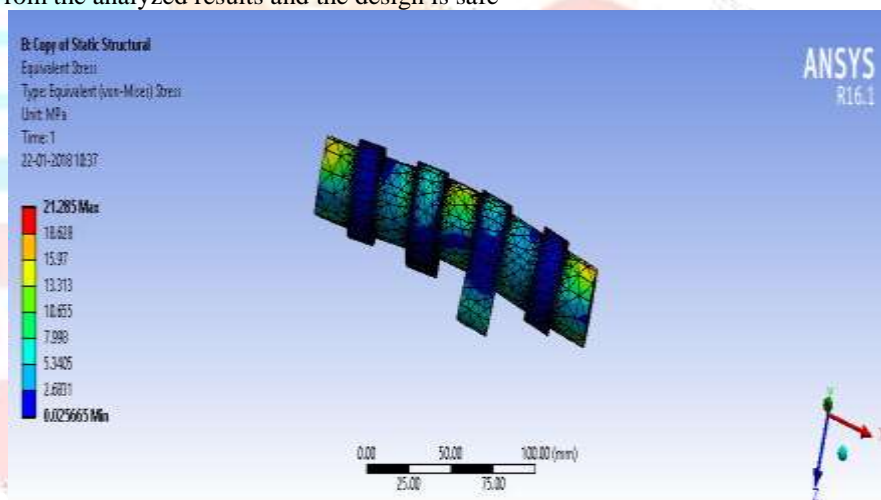

Fig7.stress analysis

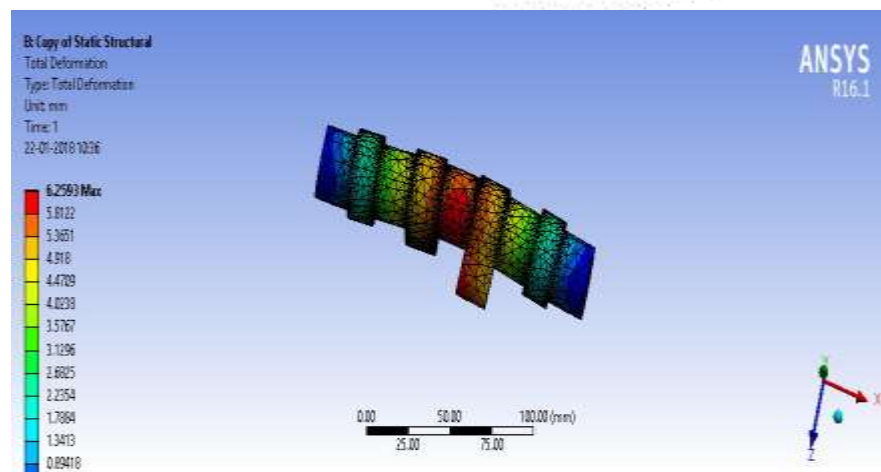

Fig8. Total deformation

5. CONCLUSION

The obtained Static structural analysis, the Steel alloy is applicable for manufacturing the Camshaft. As the total deformation and Von-mises stress values of camshaft is less compared with cast iron. From this it's applicable for the further analysis as well as for the manufacturing processes.

REFERENCES

- [1] Dr. P. C. Sharma & D. K. Aggarwal, 'A textbook of machine design' S. K. Kataria & Sons Publications, Delhi.
- [2] A. Kolchin & V. Demidov, 'Design of Automotive Engines', MIR Publication, Moscow.
- [3] Fan Y. Chen, 'Mechanics & Design of Cam Mechanism' Ch- Cam System Dynamics-Modelling, Pergamum Press, U.S.A.
- [4] 'Design Optimization of Cam & Follower Mechanism of an Internal Combustion Engine for Improving the Engine Efficiency', Mahesh R. Mali.
- [5] A.S.Dhavale, V.R.Muttagi "Study of Modelling and Fracture Analysis of Camshaft" International Journal of Engineering Research and Applications, Vol. 2, Issue 6, November-December 2012, pp.835-842.
- [6] Mahesh R. Mali, Prabhakar D. Maskar, Shravan H. Gawande, Jay S. Bagi , " Design Optimization of Cam & Follower Mechanism of an Internal Combustion Engine for Improving the Engine Efficiency", Modern Mechanical Engineering, 2012, 2, pp.114-119.
- [7] Bayrakceken H, Uzun I. & Tasgetiren S. "Fracture analysis of a camshaft made from nodular cast iron". [1240-1245] 3 NOV 2005.
- [8] Paradon V. "An Impact Model for Industrial Cam Follower System: Simulation and Experiment". [01-11] 11th OCT, 2007.
- [9] G.K. Matthew., D.Tesar (1976), Cam system design: The dynamic synthesis and analysis of the one degree of freedom model, Mechanism and Machine Theory, Volume 11, Issue 4, Pages 247-257.

