

Detection of Liquefied petroleum gas using sensor through arduino uno microcontroller

Aastha Singh¹, Mr. Manish Verma², Mr. Lumesh Sahu³

¹Department of Electronics and Communication Kalinga University, Raipur, C.G

²Assistant Professor, Department of Electronics and Communication, Kalinga University, Raipur, C.G

³Assistant Professor, Department of Electrical, Kalinga University, Raipur, C.G

Abstract: Today in this present area where technological advances are at its vertex, there is not even a single sector which remains untouched by technology. Technology has not merely established our lives simpler, but also offers a high level of safety and security wherever required. Technological devices are available which provides refuge for all the mankind. In our day to day lives, we all use cooking fuel for cooking our daily meals, but if this fuel gets leaked due to some or the other way, and then there is a large possibility of a calamity to occur around. Hazards due to gas leakage are dangerous and can become uncontrollable if timely actions are not taken. But this gas leak mostly remains unnoticed and there should be some means to observe them so that a quick action can be brought. The paper provides home safety. One of the preventive methods to stop accident associate with the gas leakage is to install a gas leakage detection kit at vulnerable places. The aim of this paper is to provide such a safety design by detecting the leakage of LPG which is applicable for the residential premises. In this paper the leakage of gas is sensed by MQ2 sensor and notified to the user through SMS and a phone call using GSM, which is help for transforming this simple device into a most advanced gas detector system in the future.

IndexTerms - : Microcontroller, Arduino, GSM, MQ-2, LCD, SIM 800, Quad Band,

I. INTRODUCTION

Liquefied petroleum gas or liquid petroleum gas (LPG or LP gas), also referred to as simply propane or butane, are flammable mixtures of hydrocarbon gases used as fuel in heating appliances, cooking equipment, and vehicles. It is increasingly used as an aerosol propellant and a refrigerant, replacing chlorofluorocarbons in an effort to reduce damage to the ozone layer. When specifically used as a vehicle fuel it is often referred to as autogas. LPG gas is frequently used for fuel in heating, cooking, hot water and vehicles, as well as for refrigerants, aerosol propellants and petrochemical feedstock. It is the most common cooking fuel used throughout India. Besides being cheap and easily available, LPG serves as an ideal fuel for cooking purposes. With the increase in the number of people using this fuel, it is the need of the hour to provide some safety standards which are required to be implemented to lead an accident free life. The major accident related to the usage of LPG happens due to the leakage of the gas which is dangerous. Gas leaks can occur from the gas cylinders which are used in almost all the household of India.

The other possibility of gas leakage is from the gas pipeline as the old pipelines often get corroded and thus may rupture, giving way to the leakage of the gas. If LPG leaks, the chances of fire hazards are at its peak as LPG is a flammable gas. Physically LPG is an odourless gas, but Ethernet oil is added as a powerful odorant so that its leakage can be noticed easily. This is a gas leakage detection project based on Arduino UNO. The low cost project uses MQ2 gas sensor which can be calibrated to detect leakage levels based on surroundings. The installation generates a sound alert using buzzer on detection of a dangerous leakage with the help of the GSM module it is capable to broadcast messages to the stakeholders about the lpg leak. This device is at its initial level of development and with modification in future this device will also trip off the mains supply to ensure better safety and surety. The Gas Leak detector device can find application not only at residential homes but also it is applicable to hotels, restaurants and even in industries where LPG gas is used for some or the other purposes.

II. MODEL DESCRIPTION AND ANALYSIS

A). ARDUINO UNO MICROCONTROLLER:-

The Arduino Uno is a microcontroller board based on the ATmega328 (datasheet). It has 14 digital input/output pins (of which 6 can be used as PWM outputs), 6 analog inputs, a 16 MHz crystal oscillator, a USB connection, a power jack, an ICSP header, and a reset button. It contains everything needed to support the microcontroller; simply connect it to a computer with a USB cable or power it with a AC-to-DC adapter or battery to get started. UNO Microcontroller is programmed using an Arduino Integrated Environment or rather Arduino Software [IDE]. This IDE helps in writing an instruction code for the Arduino. Arduino can interact with buttons, LEDs, motors, speakers, GPS units, cameras, the internet, and even your smart-phone or your TV!

B). MQ2 SENSOR:-

MQ-2 gas sensor has high sensitivity to LPG, Propane and Hydrogen, also could be used to Methane and other combustible steam, it is low cost and suitable for various applications. Using high-quality dual-panel design, with a power indicator and TTL signal output instructions; With a the DO switch signal (TTL) output, and AO analog signal output; TTL output valid signal is low level; (When the low level output signal lights, it can be connected directly to the microcontroller or relay module) TTL output signal can be connected directly to a microcontroller IO port or connect to the relay module, potentiometer is used to adjust the output level transition threshold.

C).BUZZER:-

A buzzer or beeper is an audio signaling device, which may be mechanical, electromechanical, or piezoelectric. Typical uses of buzzers and beepers include alarm devices, timers, and confirmation of user input such as a mouse click or keystroke Such buzzers are used in gas alarms, burglar alarms, etc. In this detector the buzzer gives the output sound when the LPG gas is detected by the sensor. So the buzzer serves as the audio output of the detector.

D).LCD DISPLAY:-

An LCD is an electronic display module which uses liquid crystal to produce a visible image. The 16×2 LCD display is a very basic module commonly used in DIYs and circuits. The 16×2 translates o a display 16 characters per line in 2 such lines. In this LCD each character is displayed in a 5×7 pixel matrix.

E). SIM800 GSM MODULE:-

This GSM Modem can accept any GSM network operator SIM card and act just like a mobile phone with its own unique phone number. Advantage of using this modem will be that you can use its RS232 port to communicate and develop embedded applications. The MODEM needs AT commands, for interacting with processor or controller, which are communicated through serial communication. These commands are sent by the controller/processor. The MODEM sends back a result after it receives a command It requires supply voltage in the range 3.4 ~ 4.4V

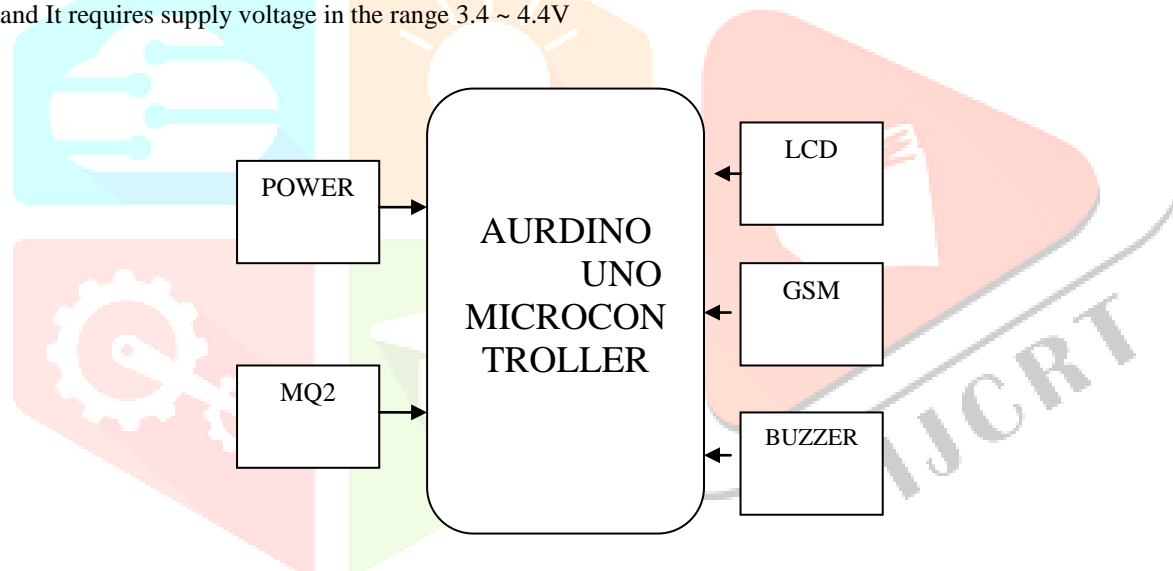

Fig1. Block diagram for gas detection

III .METHODOLOGY

The important and the most useful part of the system is Arduino Uno. All the output devices are controlled by Arduino. At the same time it reads and manipulates the input from sensor. The MQ2 sensor has an electrochemical sensor, which changes its resistance for different concentrations of varied gasses. The sensor is connected in series with a variable resistor to form a voltage divider circuit (Fig 1), and the variable resistor is used to change sensitivity. When one of the above gaseous elements comes in contact with the sensor after heating, the sensor's resistances change. The change in the resistance changes the voltage across the sensor, and this voltage can be read by a microcontroller. The voltage value can be used to find the resistance of the sensor by knowing the reference voltage and the other resistor's resistance. The sensor has different sensitivity for a different type of gasses.

The sensitivity characteristic curve is shown below for the different type of gasses.

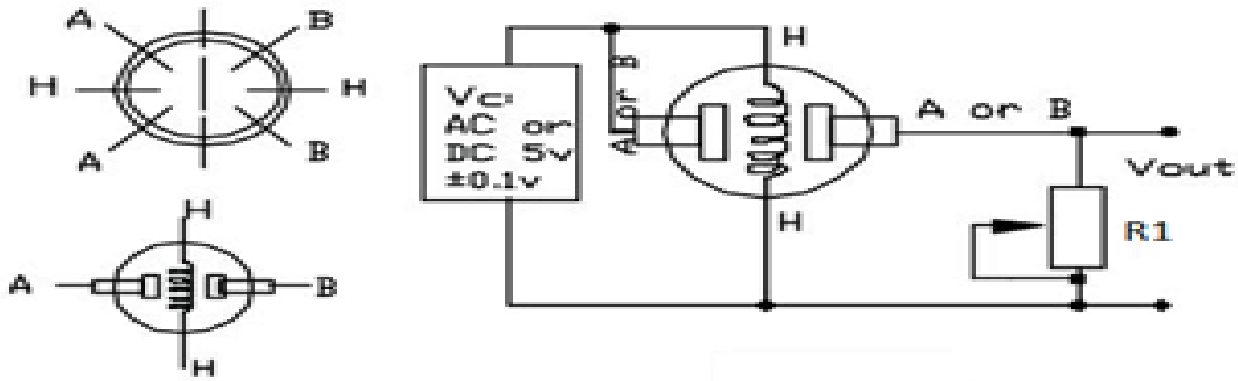

Fig2. Sensor is connected in series with a variable resistor to form a voltage divider circuit

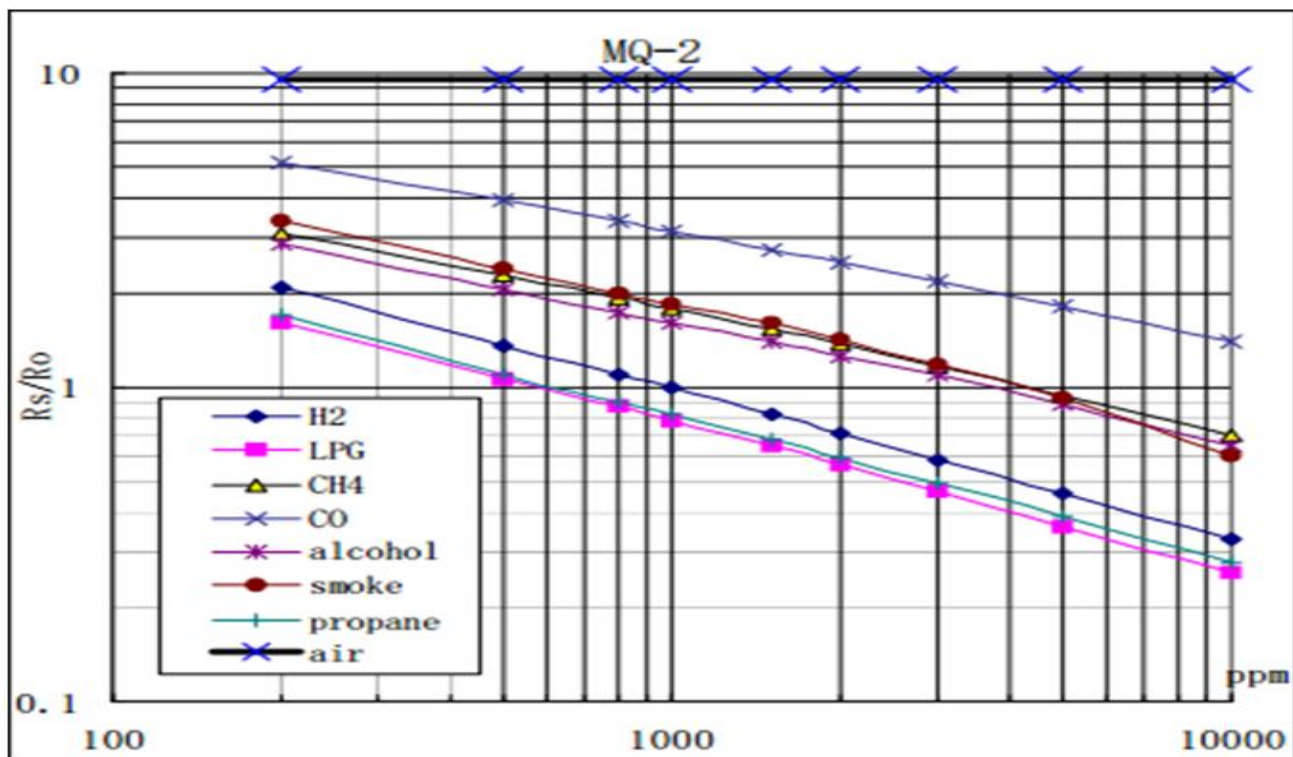

Fig3. Characteristic curve for the different type of gasses.

Where,

1. Ro is the resistance of the sensor in clean air
2. Rs is the resistance of sensor when exposed to gasses

The functionality of system is divided into three main steps. In the initial step, the gas leakage is detected by the gas sensor. This detects the gas leakage and gives the signal to the microcontroller. After that in second step the microcontroller receives the signal, which sends by gas sensor. It sends activation signal to other external devices attached such as LCD display .The LCD display will show which gas is actually detected.

LCD Display receives various messages from Arduino. User receives SMS indication with the help of GSM modem connected to the Arduino Uno board. This circuit indicates the amount of LPG in the air. The circuit sounds an alarm and trips a relay when the concentration is above a predetermined level. MQ2 is the gas sensor used in this project. MQ2 is a SnO₂ based gas sensor which can sense gases like methane, propane, butane, alcohol, smoke, hydrogen etc. Since LPG primarily contains propane and butane, MQ2 sensor can be used for sensing LPG. When the sensors detect the gas in the air, then Message displayed on LCD “GAS LEAK” and the Buzzer emits Sound and message will send to the registered number. At the same time we can also attach an exhaust fan with the controller to control the gas leakage. when message receive by the user they can give instructin through

msg and when the controller receive the message then fan is on. here we are using fan for emitting the gas outside the room i.e for decreasing the concentration of gas inside the room.

When LPG gas does not detect Message displayed on LCD “NO GAS LEAK” and no sound emitted from Buzzer. No message sent.

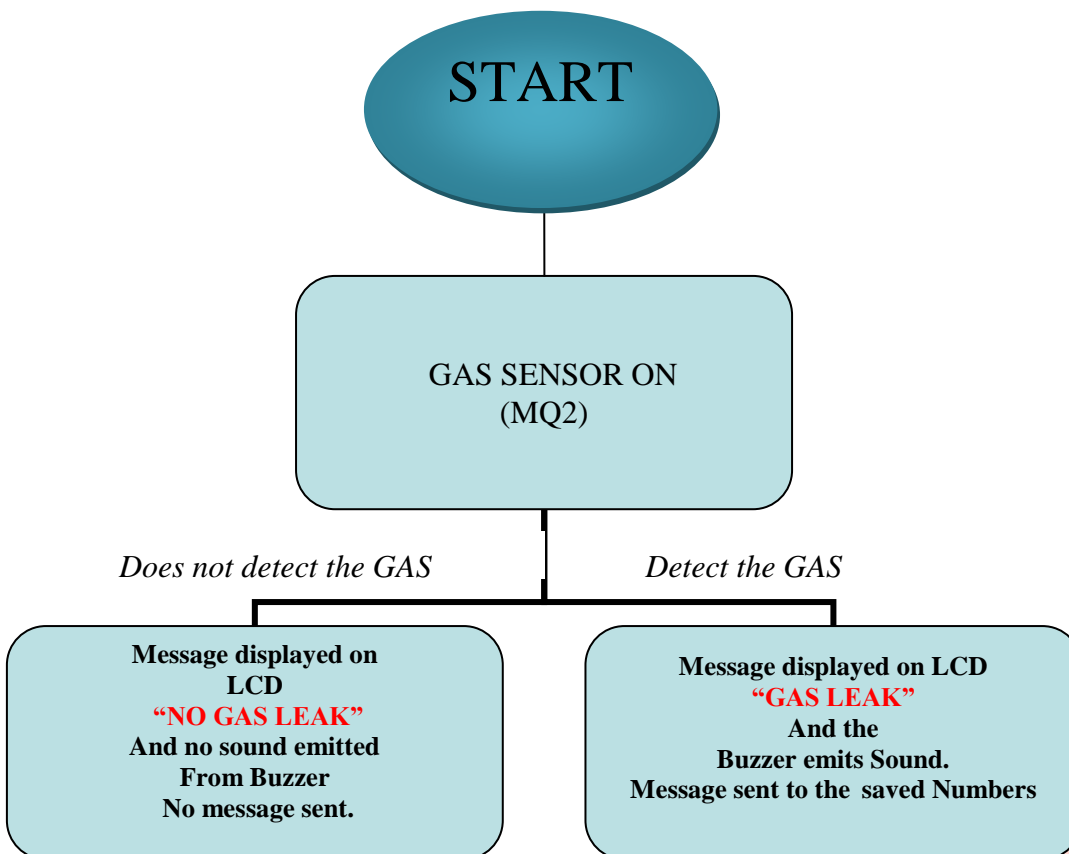

Fig4. Flowchart of the working

IV. FUTURE SCOPE

There are many ways in which this gas leak detector can be modified and made more complex by including more advanced features into it. The gsm module enables us to send the gas leak message to the relevant stakeholders and hence it increases the efficiency of this system. Usage of GSM module for this detector prevents the accidents from taking a hazardous turn. The other modification which can be implemented in this gas leak detector is using a tripper circuit which will trip off the main supply once the gas leak is detected. During a gas leak it is dangerous to switch any appliances as it may spark and this tripper circuit helps to reduce the electrical hazards that can be caused due to a gas leak. Along with the tripping off of the main supply it is very much necessary to turn off the gas regulator so that no further leakage of the gas occurs. A robot has been used in replacing human for handling various tasks in a hazardous and dangerous workplace where human life may at risk. A mobile gas sensing robot can be constructed to sense the leakage of gas through pipelines as the robot can move on a track which is situated along the length of pipeline. This technique further increases the overall efficiency of the system and makes the system a perfect gas leak detector providing overall safety of the residents.

V. CONCLUSION

This project is very useful to prevent accident due to gas leakage. Each flame and gas detection application has its own unique safety hazards. If we implement this in broad way, it is very successful. The main advantage of this simple gas leak detector is its simplicity and its ability to warn its stakeholders about the leakage of the LPG gas. It is also detect alcohol so it can be useful for liquor test. The sensor has excellent sensitivity combined with a quick response time. This sensor is Long life and stable and simple drive circuit. Due to its fast response time and high sensitivity, measurements can be taken as soon as possible. The sensor sensitivity can be adjusted by using the potentiometer.

ACKNOWLEDGMENT:-

I convey my sincere thanks and gratitude to my project guide **Mr. Manish Verma** (Assistant Professor, Department of Electronics & communication Engineering), **Mr. Lumesh Sahu** (Assistant Professor, Department of Electrical), for providing me all sorts of facilities. Their support and guidance helped me to carry out the project. It will be my pleasure to acknowledge, co-operation and valuable suggestion from time to time given by professors.

REFERENCE

1. Aravinda Beliraya” GSM Based Gas Leakage Detection System Using Arduino” Volume 4, Issue 10 October 2017
2. J.M.Huges, Aurdino A Technical Reference ,O’Reilly Media,Inc,May 2016
3. Mr. Akshay D. Prabhu,Mr. Ashwin D. Pathak” Gas Leak Detector using Arduino UNO Microcontroller” Volume 5 Issue VII, July 2017
4. Ahuja, R.B., Bhattacharya, S. “An analysis of 11,196 burn admissions and evaluation of conservative management techniques”, Burns, 2002; Volume 28
5. C. Selvapriya, S. Prabha Sathya, M. Abdulrahim, C. K. Aarthi, “ LPG Leakage Monitoring and Multilevel Alerting System”, International Journal of Engineering Sciences & Research Technology, Volume 2, Issue 11, November 2013
6. Prof. Pankaj C. Warule, Shivam Upadhyay, Snehal S. Shelke, Sumitra K. Khandade, “LPG Detection, Metering and Control System Using Microcontroller”, Volume 2, Issue 2, 2016,

