

# ANTI-THEFT MOTORCYCLE (AT-MOTO) KIT: USING ARDUINO AND AUTO-CALL GSM-900

<sup>1</sup>Abhishek Das, <sup>2</sup>Satywan Kumar

<sup>1</sup>Assistant Professor, <sup>2</sup>B.Tech Student

Department of Electronics and Communication Engineering,  
Raajdhani Engineering College, Bhubaneswar, India

**Abstract:** The need for motorcycle security system is a serious concern now days. Different security systems are available in the market. But the kit with full protection is not yet designed. So idea for AT-MOTO kit using which a motorcycle owner will be fully satisfied will be practicable using Arduino and Auto call GSM-900. Most of the thieves use the master keys to unlock the bikes and then steal them. In our design we have used this method of thieves to detect this activity using the Arduino circuit board, RFID card and GSM-900 to inform the motorcycle owner by call and message. This method can be used in other equipments where any key is used to open the system to prevent theft and to aware the user of that equipment about the activity done by thieves. The most important point in this method is it can be produce in lower price as compare to the price of the bikes available in market and can be used in every model of bikes.

**Index Terms – AT-MOTO Kit, Arduino, RFID Card, GSM-900, Anti-theft**

## I. INTRODUCTION

Theft of the vehicle has become a serious problem for us now days. The cost of bike varies depending upon the company but for a owner his/her bike is the way to reach the target place which means that any motorcycle is very important for a bike owner. Different Insurance companies are providing the price for loss of vehicle but that is also time taking which is not suitable for our busy life. In general the thieves keep lots of keys with them and they use those keys on trial basis. If the bike opens with any key they drive anyone's vehicle in very easy way. Keeping this serious problem in mind, we have thought of a kit through which we can prevent theft of the vehicle and catch the thieves. After using this Anti-Theft Motorcycle (AT-MOTO) kit, no other person can insert any type of key in the lock of the vehicle except the owner of the vehicle. The kit will include a RFID tag to open and close the vehicle. As we know the RFID tags have certain number which will be read by the Arduino circuit only, the closing and locking of motorcycle will be fully secured as there is no question to use the false keys by thieves. A servo motor will control the locking and opening the socket where the actual key will be inserted and the owner will be able to start the motorcycle.

Using RFID tag we can prevent the use of other keys by thieves but if the concern is to catch the thieves during trying to open the lock of bike we can use the concept of calling and messaging the owner by GSM-900 along with the Arduino. This is done with the help of the servo motor used for locking and opening the motorcycle and the metallic socket used to insert the key. So the activity of thief will be detected due to short circuit between the metallic socket and servomotor by the key used by the thief and a call & message will be transferred by the GSM-900 to the number of bike owner provided to Arduino by the programs.

This is the way to prevent the theft of motorcycles using the concept thought by us using Arduino and GSM-900. The details of this procedure is described bellow with suitable block diagrams, circuit diagrams and their explanation.

## II. RELATED WORKS

In RFID based vehicle monitoring system [1] the RFID based module is used to detect the vehicles entering the specified area and an integrated Arduino camera module that captures vehicle images. So RFID module, Arduino and GSM module can be used to provide protection to vehicles.

Various processes are adopted by different companies to provide safety for bike. In market the GPS Tracker kit is available. But the use of GPS Tracker will be to track the location of the bike after the bike is theft. The owner have to run here and there for help from police department. Although the use of GPS tracker is useful the time will be consumed more for tracking the location of bike and to get it back which is not suitable for a busy schedule life. So use of GPS Tracker is not fully efficient.

Disc locks are available for the bikes having disc break but if the owner forgets to use the disc lock then the possibility of being stolen will be increased. Also it can't be used in normal bikes having no disc break. So it can't be considered as fully protective.

## III. METHODOLOGY OF AT-MOTO KIT

**3.1 Working of this concept depends on the use of following components:**

**1.Arduino:** - Arduino is an open-source electronics platform based on easy-to-use hardware and software[3]. Arduino boards are able to read inputs - light on a sensor, a finger on a button, or a Twitter message - and turn it into an output - activating a motor, turning on an LED, publishing something online. You can tell your board what to do by sending a set of instructions to the

microcontroller on the board. To do so you use the Arduino programming language (based on Wiring), and the Arduino Software (IDE), based on Processing.

**2.RFID :- Radio-frequency identification (RFID)** uses electromagnetic fields to automatically identify and track tags attached to objects. The tags contain electronically stored information. Passive tags collect energy from a nearby RFID reader's interrogating radio waves. Active tags have a local power source (such as a battery) and may operate hundreds of meters from the RFID reader. Unlike a barcode, the tag need not be within the line of sight of the reader, so it may be embedded in the tracked object. RFID is one method for Automatic Identification and Data Capture

**3.GSM module:- GSM (Global System for Mobile Communications, originally Group Special Mobile)** is a standard developed by the European Telecommunications Standards Institute (ETSI) to describe the protocols for second-generation digital cellular networks used by mobile devices such as tablets, first deployed in Finland in December 1991. As of 2014, it has become the global standard for mobile communications – with over 90% market share, operating in over 193 countries and territories.

### 3.2 Specialty of this Kit

1. One metallic plate will be present just after and inside the first layer of lock.
2. This plate will act as an open and close gate for the entering of key.
3. Initially the gate will be closed, it will be open if and only when the owner who have a specific card. When he will show the card to the card reader then the gate will be open which will present inside the lock then after open the gate owner can insert the key.
4. Any other person cannot insert the key without open the internal gate (which is controlled by RFID).
5. If any other person try to insert any types of another key in the lock then the vehicle will act as a Robot itself and immediately will make a call to the phone number of the owner.

### 3.3 Construction: -

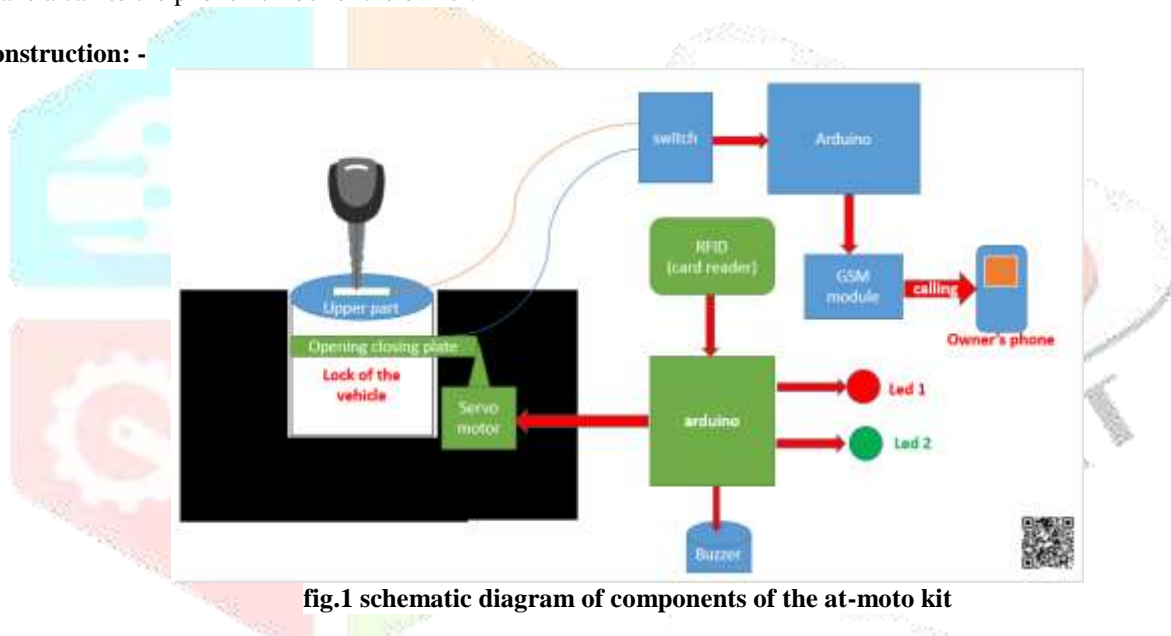

fig.1 schematic diagram of components of the at-moto kit

There are the following step for construction:-

1. First of all owner has a unique card inside which a password will be predefined by the card manufacturer.
2. We will define the same password to the Arduino with the help of programming.
3. To read that card we need one card reader and the RFID circuit will be act as a card reader.
4. RFID will connected to the Arduino.
5. Arduino will be connected to the servo motor, buzzer and two LED.
6. The shaft of the servo motor will be connected with one plate which will be present inside the upper face of the lock.
4. This plate will be act as a gate which will be open and close by the help of servo motor and the servo motor will be controlled by the Arduino and this Arduino will be connected to the RFID.
5. Two wires, positive and negative wires will be connected to the upper part and the opening closing plate respectively.
6. When these will be short then one switch will be connected with two wires so switch will be closed.
7. This switch will be connected to one another Arduino board.
8. When the circuit will be short then it send the command to the GSM board to call the owners phone number. So GSM module will be connected with the Arduino.

### 3.4 Working Principle:-

1. First of all owner who have one specific card, show those card to the card reader (RFID CIRCUIT).
2. The same password of that card will be defined in the arduino.
3. When the password will not be match than arduino send the command to the red led bulb and buzzer and these two will be active.
4. If password will be match then arduino send the command to the servo motor to rotate from 0 to 180 degree.

5. Due to this rotation the opening and closing plate will open (these plate will act as a gate of the lock for the entering of the key).
6. When the gate will open then owner can insert the key to the lock.
7. But any other person who have not this unique card then servo motor will not open and the gate will remains close.
8. and in this condition if any person try to insert any types of key then the circuit will be closed (short) and when the circuit will be short then arduino send the command to the GSM module that call the vehicle owner's phone which number will be predefined by us with the help of programming in Arduino.
8. so if any another person try to insert any other types of key without opening the RFID controlled gate then The vehicle will act as a **robot** itself and at the same time the vehicle will call the vehicle owner's phone.

#### IV. ALGORITHM FOR AT-MOTO KIT

##### 4.1 ALGORITHM (FOR OPENING AND CLOSING OF LOCK)

- Step.1 To open, Owner shows the RFID tag on the card reader
- Step.2 If  
Number on the RFID tag = the number provided to Arduino
- Step.3 then  
Servo motor rotates and the socket for inserting key opens
- Step.4 Owner inserts the key and starts ignition
- Step.5 else  
Servo motor does not open and no possibility of ignition
- Step.6 To lock, the owner takes out the key from the socket
- Step.7 Owner shows the RFID tag
- Step.8 Servo motor rotates to close the socket

##### 4.2 ALGORITHM (FOR DETECTION OF THEFT AND AWARING THE MOTORCYCLE OWNER)

- Step.1 If  
Thief inserts the key and tries to open
- Step.2 there will be a short circuit between upper plate and servo motor
- Step.3 then  
Circuit for Arduino and GSM-900 will be completed
- Step.4 and call and message will be auto generated to the bike owner
- Step.5 The bike owner will be aware about the activity

#### V. PROGRAM USED TO OPERATE THE AT-MOTO KIT

```
#include <SPI.h>
#include <MFRC522.h>
#include <Servo.h>

#define SS_PIN 10
#define RST_PIN 9
#define LED_G 5 //define green LED pin
#define LED_R 4 //define red LED
#define BUZZER 2 //buzzer pin
MFRC522 mfrc522(SS_PIN, RST_PIN); // Create MFRC522 instance.
Servo myServo; //define servo name

void setup()
{
  Serial.begin(9600); // Initiate a serial communication
  SPI.begin(); // Initiate SPI bus
  mfrc522.PCD_Init(); // Initiate MFRC522
  myServo.attach(3); //servo pin
  myServo.write(0); //servo start position
  pinMode(LED_G, OUTPUT);
  pinMode(LED_R, OUTPUT);
  pinMode(BUZZER, OUTPUT);
  noTone(BUZZER);
  Serial.println("Put your card to the reader...");
  Serial.println();
}
```

```

}
void loop()
{
// Look for new cards
if ( ! mfrc522.PICC_IsNewCardPresent())
{
return;
}
// Select one of the cards
if ( ! mfrc522.PICC_ReadCardSerial())
{
return;
}
//Show UID on serial monitor
Serial.print("UID tag :");
String content= "";
byte letter;
for (byte i = 0; i < mfrc522.uid.size; i++)
{
Serial.print(mfrc522.uid.uidByte[i] < 0x10 ? " 0" : " ");
Serial.print(mfrc522.uid.uidByte[i], HEX);
content.concat(String(mfrc522.uid.uidByte[i] < 0x10 ? " 0" : " "));
content.concat(String(mfrc522.uid.uidByte[i], HEX));
}
Serial.println();
Serial.print("Message : ");
content.toUpperCase();
if (content.substring(1) == "XX XX XX XX") //change here the UID of the card/cards that you want to give access
{
Serial.println("Authorized access");
Serial.println();
delay(500);
digitalWrite(LED_G, HIGH);
tone(BUZZER, 500);
delay(300);
noTone(BUZZER);
myServo.write(180);
delay(5000);
myServo.write(0);
digitalWrite(LED_G, LOW);
}
else {
Serial.println(" Access denied");
digitalWrite(LED_R, HIGH);
tone(BUZZER, 300);
delay(1000);
digitalWrite(LED_R, LOW);
noTone(BUZZER);
}
}

```

## V. SIMULATION AND RESULTS

We have used the Fritzing software to design the circuit virtually and to test the working principle of the AT-MOTO kit. The result was as per our considerations and successfully verified. As the virtual result is useful its practical implementation will also be useful for bike owners.

The Circuits designed using Fritzing Software are given to provide basic idea about the AT-MOTO kit.

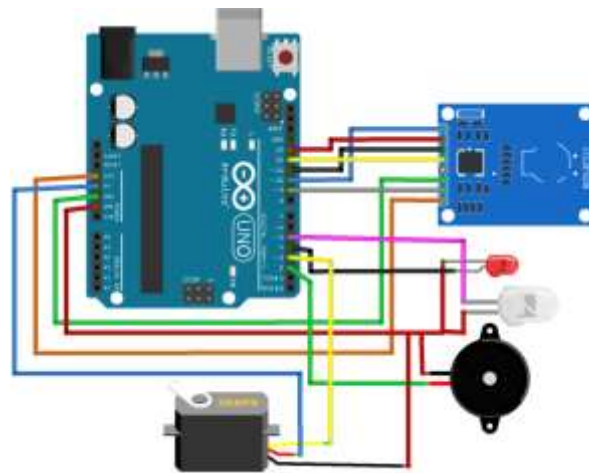

fig.2 design of arduino circuit for locking and opening the lock

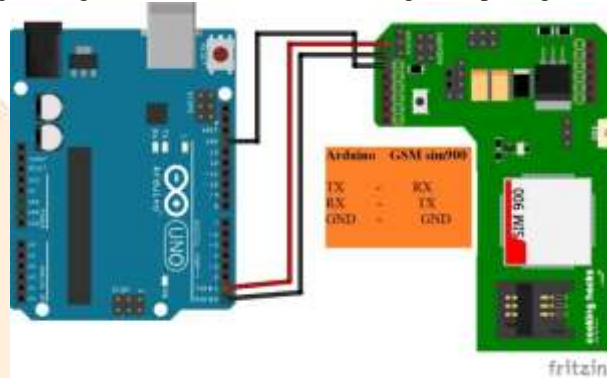

Fig.3 Circuit design for call and message service by the Arduino

## VI. FUTURE WORKS

As the future work we can modify the function of this kit to inform the local police station that a thief is trying to steal the bike using Arduino along with GPS system which will detect the location of bike and the nearest police station so that there will be a chance that the thief may be caught at spot. This kit can be manufactured and supplied to the market so that a huge number of motorcycle users will be benefited.

## VII. CONCLUSION

By considering the use of RFID based opening and locking system we have thought to stop the stealing of bike and by using the Arduino and GSM-900 it emphasizes the importance of this kit as the information about the theft is transferred to the owner. As a whole it can be considered that this kit is fully protective in comparison to other products available in the market. AT-MOTO kit is so designed that it will be producible as well as cost effective. Arduino along with GSM-900 based other security systems can also be designed using this concept.

## VIII. ACKNOWLEDGEMENT

We would like to express our special thanks of gratitude to Raajdhani Engineering College, Bhubaneswar to motivate us to do research and development works on Arduino based Embedded system.

## REFERENCES

- [1] RFID-based vehicle monitoring system Edward B. Panganiban; Jennifer C. Dela Cruz 2017 IEEE 9th International Conference on Humanoid, Nanotechnology, Information Technology, Communication and Control, Environment and Management (HNICEM) Year: 2017 Pages: 1 – 6 IEEE Conferences
- [2] An advanced security system integrated with RFID based automated toll collection system Rafiya Hossain; Moonmoon Ahmed; Md. Mozadded Alfasani; Hasan U. Zaman 2017 Third Asian Conference on Defence Technology (ACDT) Year: 2017 Pages: 59 – 64, IEEE Conferences
- [3] To know about Arduino: - <https://www.arduino.cc>