

SMART DRIP IRRIGATION SYSTEM FOR CORPORATE FARMING-USING INTERNET OF THINGS

Mrs R.Naga Swetha 1, J.Nikitha 2, Mrs B.Pavitra 3

1) R.NagaSwetha, Assistant professor, Anurag Group of institutions, Telangana, India

2) J.Nikitha, pg scholar, Anurag Group of Institutions, Telangana, Hyderabad, India

3) B.Pavitra, Assistant professor, Anurag Group of Institutions, Telangana, India

ABSTRACT

Drip irrigation system makes the efficient use of water & fertilizers. The concept of this irrigation system is to irrigate only the root zone of the plants. Drip irrigation allows water to drip slowly to the roots of plants. Drip is especially suitable for arid, hot and windy areas. Drip irrigation system which supply controlled amounts of water to plants. Subsurface application of water to the root zone also has the potential to improve yields by reducing the incidence of disease.

The data from sensors is continuously uploaded to the cloud hosted for drip irrigation system. This system also enables suggestions for the admin & user. The motor can be ON-OFF with mobile application and automatically. With an intelligent data analytics algorithm this system can optimize the utilization of water and can cultivate more food.

I INTRODUCTION

In our country Agriculture is major source of food production to the growing demand of human population. In agriculture, irrigation is an essential process that influences crop

Production. Generally farmers visit their agriculture fields periodically to check soil moisture level and based on requirement water is pumped by motors to irrigate respective fields. Farmer need to wait for certain period before switching off motor so that water is allowed to flow in sufficient quantity in respective fields. This irrigation method takes lot of time and effort particularly when a farmer need to irrigate multiple agriculture fields distributed in different geographical areas. Automation in irrigation system makes farmer work much easier. Sensor based automated irrigation system provides promising solution to farmers where presence of farmer in field is not compulsory. A small processor programmed for control a electromagnetic valve and also compare to electromagnetic valve operate motor to start watering.

II LITERATURE REVIEW

For development of automated irrigation system, soil moisture content is more important parameter as compared to others as it has crucial role in plant growth mechanism and availability of water for irrigation is major concern for the farmers specially the ones who are dependent on rain. Hence water management has high priority while designing automated irrigation system as seen in most of the literature.

In this system, a smart drip irrigation system model integrating Internet of Things

(IOT) technologies for decoupling decision support systems and monitoring from business processes coordination and subsystem implementation. The rest of the paper is as follows: Section II describes open challenges in the definition of drip irrigation models, Section III and IV define the requirements taken into

account for our architecture proposal and a high level architecture respectively. Section V introduces the integration of IOT into the drip irrigation system and Section VI describes in detail the proposed MEGA model, followed by a discussion.

III PROJECT HARDWARE

Block Diagram:

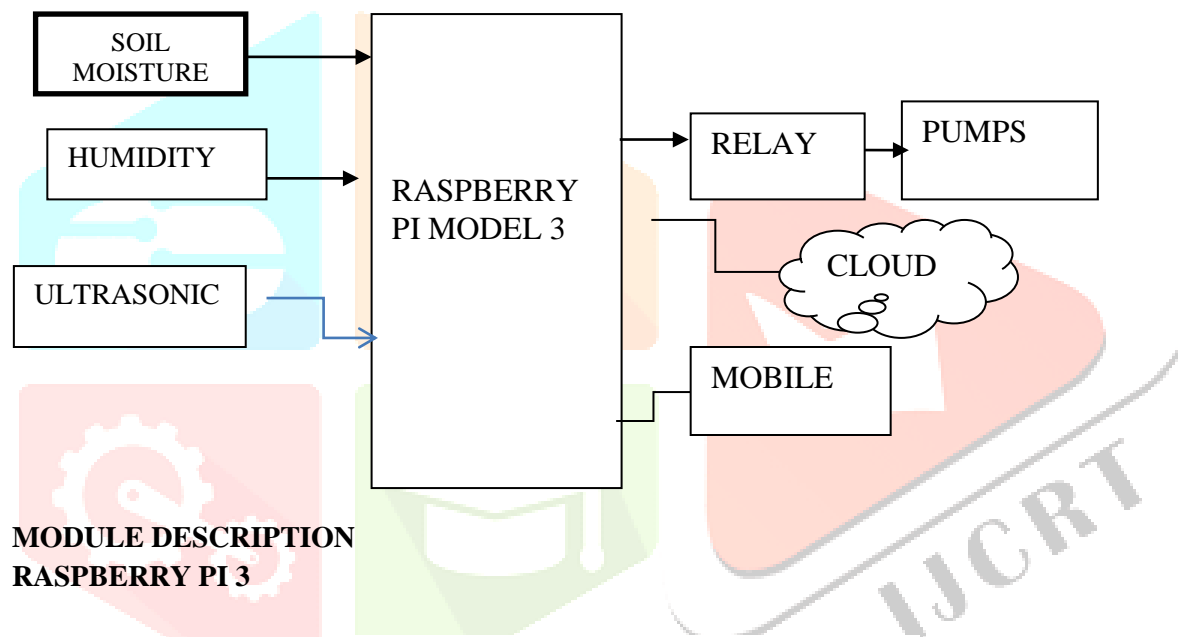

The Raspberry Pi 3 is the third generation Raspberry Pi. It replaced the Raspberry Pi 2

Model B in February 2016. Compared to the Raspberry Pi 2 it has:

- A 1.2GHz 64-bit quad-core ARMv8 CPU
- 802.11n Wireless LAN
- Bluetooth 4.1
- Bluetooth Low Energy (BLE)
- Like the Pi 2, it also has:
- 1GB RAM
- 4 USB ports
- 40 GPIO pins
- Full HDMI port
- Ethernet port

XBEE

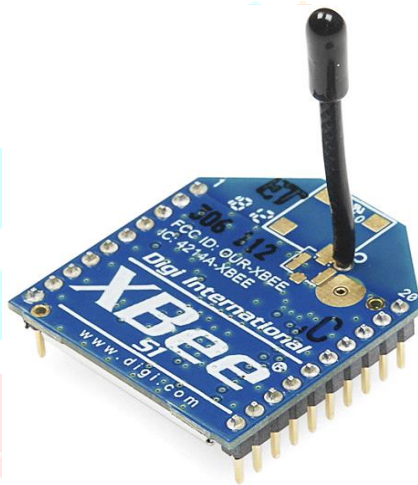

XBees are hugely popular wireless transceivers for a number of reasons. They're flexible they send and receive data over a serial port, which means they're compatible with both computers and microcontrollers (like Arduino). And they're highly configurable. You can have meshed networks with dozens of XBees, or just a pair swapping data. You can use them to remotely control your robot, or arrange them all over your house to monitor temperatures or lighting conditions in every room

ULTRASONIC SENSOR



Fig: Ultrasonic Sensor

Ultrasonic transmitter emitted an ultrasonic wave in one direction, and started timing when it launched. Ultrasonic spread in the air, and would return immediately when it encountered obstacles on the way. At last, the ultrasonic receiver would stop timing when it received the reflected wave.

Ultrasonic Application Technology is the thing which developed in recent decades. With the ultrasonic advance, and the electronic technology development, especially as high-power semiconductor device technology matures, the application of ultrasonic has become increasingly widespread:

SOIL MOISTURE SENSOR



Soil moisture sensor measure the volumetric water content in soil. Since the direct gravimetric measurement of free soil moisture requires removing, drying, and

weighting of a sample, soil moisture sensors measure the volumetric water content indirectly by using some other property of the soil, such as electrical resistance, dielectric constant, or interaction with neutrons, as a proxy for the moisture content. The relation between the measured property and soil moisture must be calibrated and may vary depending on environmental factors such as soil type, temperature, or electric conductivity. Reflected microwave radiation is affected by the soil moisture and is used for remote sensing in hydrology and agriculture.

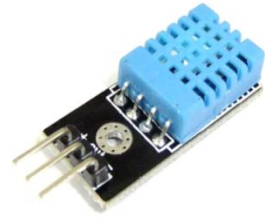

DHT -11 SENSORS

Fig: Humidity Sensor

Each DHT11 element is strictly calibrated in the laboratory that is extremely accurate on humidity calibration. The calibration coefficients are stored as programs in the OTP memory, which are used by the sensor's internal signal detecting process. The single-wire serial interface makes system integration quick and easy. Its small size, low power consumption and up-to-20 meter signal transmission making it the best choice for various applications, including those most demanding ones.

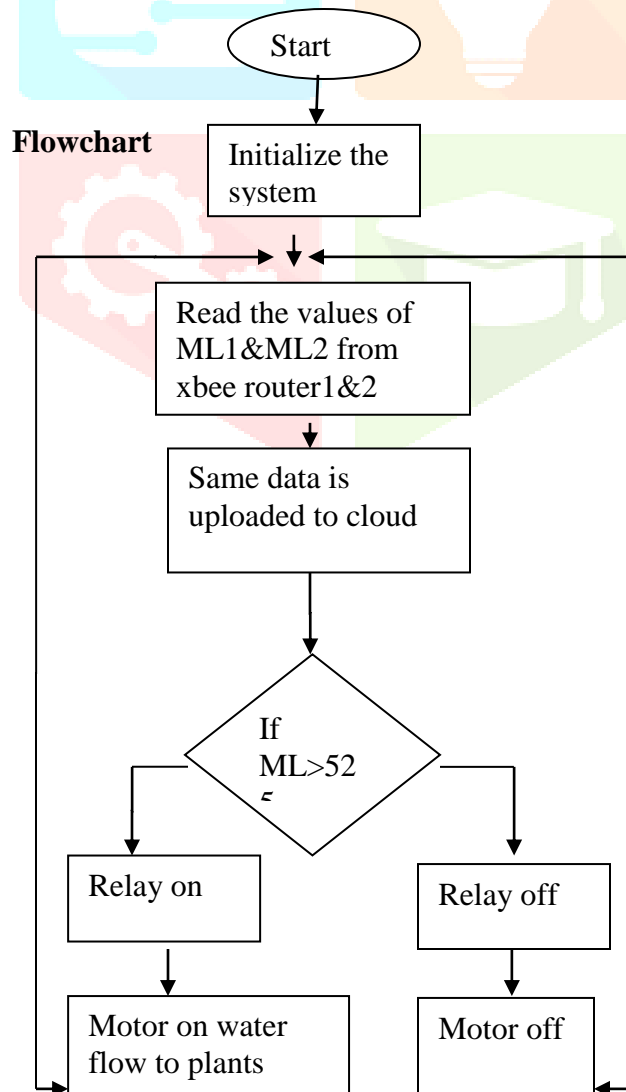

IV SOFTWARE REQUIREMENTS

Operating System	- Linux
Server design	- PHP
Database Design	- MySQL
Web page Design	- Bootstrap
Language	- Python

V RESULT

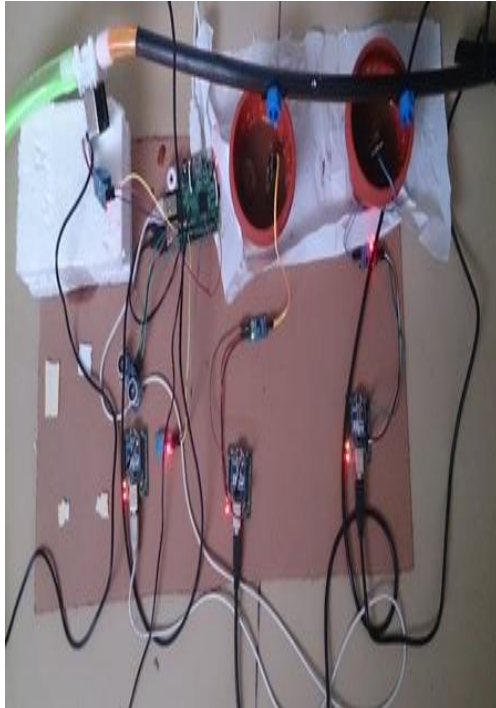

Fig: Complete Project Kit

Test Plan:

First raspberry pi is powered and ethernet cable is connected to raspberry pi ethernet shield.

- Water level from ultrasonic sensor is read and uploaded to webpage and mobile application.
- Soil moisture and humidity sensor values are uploaded to webpage and mobile application.
- Depending on the soil moisture values the valves will be open.
- By using mobile application we can ON-OFF motor.
- It can be done automatically and manually.

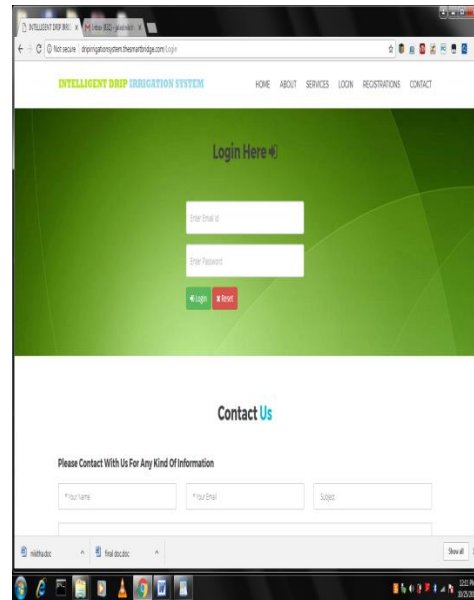

Fig: Web Login Page

SNo	Moisture 1	Moisture 2	Date
1	19.0	92.1	08/27 pm 12:00:2017
2	92.1	89.0	08/27 pm 12:00:2017
3	19.0	92.1	08/27 pm 12:00:2017
4	92.1	89.0	08/27 pm 12:00:2017
5	19.0	92.1	08/28 pm 12:00:2017
6	92.1	89.0	08/28 pm 12:00:2017
7	19.0	92.1	08/28 pm 12:00:2017
8	92.1	89.0	08/28 pm 12:00:2017
9	19.0	92.1	08/28 pm 12:00:2017
10	92.1	89.0	08/28 pm 12:00:2017

Fig: Values of Moisture

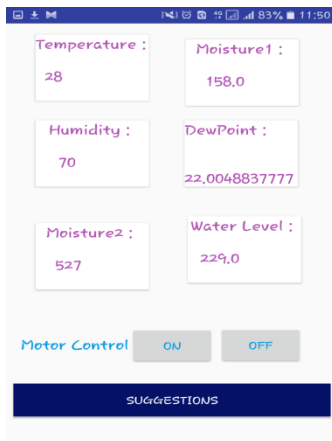

fig 3 temp,humidity,moisture values shown in mobile application

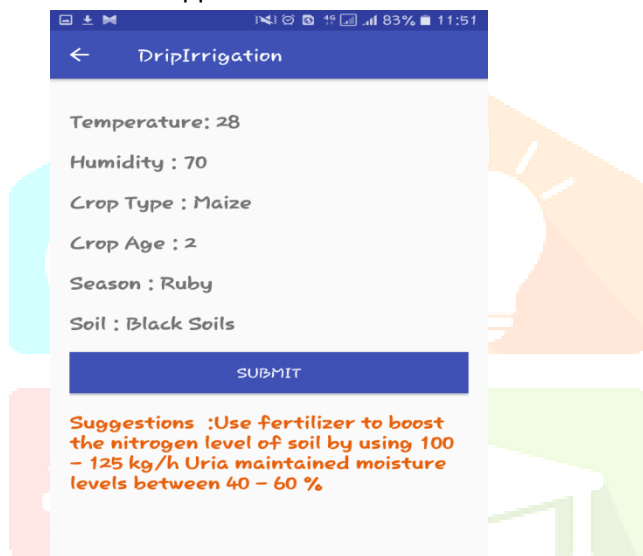

Fig :suggestions are given to user

VI CONCLUSION & FUTURE SCOPE

The system involves instrumentation system for measurement of water level in tanks. The data from sensors is continuously uploaded to the cloud hosted for drip irrigation system. This system also enables suggestions for the admin & user. The motor can be ON-OFF using mobile application and automatically with an intelligent data analytics algorithm this system can optimize the utilization of water and can cultivate.

The proposed system has wireless xbee modules xbee routers and xbee coordinator. The xbee router will send the data to coordinator we can use 2 nodes at a time for transmitting data.

REFERENCES

- [1] Dr.p.h.zopeternational journal of engineering sciences & research technology (IJESRT) survey of smart irrigation system .2009
- [2] Jeonghwan Hwang, Changsun Shin, and Hyun Yoe “Study on an Agricultural Environment Monitoring Server System using Wireless Sensor Networks”, 2010.
- [3] MotorR.Jaichandran, Sudharsan K.P, International Journal of Innovative Research in Computer and Communication Engineering (IJRCCE) Prototype for Automatic Controlling and Remote Accessing of Irrigation .2012
- [4] R.Hussain, J.Seegal, A.Gangwar, M.Riyag“ Control of irrigation automatically by using wireless sensor network” International journal of soft computing and engineering, vol.3, issue 1, march 2013
- [5] Soule Roy, SomprakashBandyopadhyay, “A Test-bed on Real-time Monitoring of Agricultural Parameters using Wireless Sensor Networks for Precision Agriculture”
- [6] Yiming Zhou, Xianglong Yang, Liren Wang, Yibin Ying, A wireless design of low-cost irrigation system using ZigBee technology, 2009 International Conference on Networks Security, Wireless Communications and Trusted Computing, 978-0-7695-3610-1/09 , IEEE