

# FABRICATION OF AUTOMATIC PNEUMATIC DOUBLE AXIS WELDING MACHINE

<sup>1</sup>Mr.Sateesh.R, <sup>2</sup>Sreenithi.R.M, <sup>3</sup>Tamilmani.R, <sup>4</sup>Tamil Selvan.V, <sup>5</sup>Vasanthakumar.A

<sup>1</sup>Assistant professor,<sup>2,3,4,5</sup>Students

<sup>1</sup>Department of Mechanical Engineering

<sup>1</sup>Gnanamani College of Technology, Namakkal, India.

---

**Abstract:** In our project “AUTOMATIC PNEUMATIC DOUBLE AXIS WELDING MACHINE” is beings with an introduction to welding the various components automatically. Two pneumatic cylinder and Solenoid valve are used. Cylinder is for the forward and backward movement, it moves in both x and y axis. So, it is called as double axis welding machine. Two pneumatic cylinders and solenoid valve are provided. One cylinder is for the up and down movement and another one for the rotary motion. The problems are with the automatic process, still in their early design stages and difficult to use and program by regular operators. In this project, these problems are discussed, and a system designed with the double objective of welding applications and to assist industrial partners working with welding setups is presented.

**Index terms – Fabrication, Automatic, Double axis, Welding**

---

## I. INTRODUCTION

“Welding is the process of joining together two pieces of metal. So, that the bonding takes place at their surfaces”. When two parts to be joined are melted together, heat or pressure or both is applied and with or without added metal for formation of metallic bond.



**Fig.1.Welding**

**Welding** is a fabrication or sculptural process that joins materials, usually metals or thermoplastics, by causing fusion, which is distinct from lower temperature metal-joining techniques such as brazing and soldering, which do not melt the base metal. In addition to melting the base metal, a filler material is typically added to the joint to form a pool of molten material (the weld pool) that cools to form a joint that is usually stronger than the base material. Pressure may also be used in conjunction with heat, or by

itself, to produce a weld. Welding also requires a form of shield to protect the filler metals or melted metals from being contaminated or oxidized. Although less common, there are also solid state welding processes such as friction welding in which metal does not melt.

## II. PROBLEM IDENTIFICATION:

The current state in small scale industries is that they still using to manual welding and machining methods due to lack of economic resources and infrastructure. So, that the uniformity and quality of the weld cannot be ensured, not to mention the work hours put in and the expenditure spent on the labours. Also there is a persistent risk of causing hazards to the operator through fumes, fires, spatter flying off those machines. The idea behind fabrication of low cost Automatic welding machine is to full fill the demand of CNC welding machines for small scale to large scale industries with optimized low cost. In addition to that the quality of the weld is also quite paramount therefore using an optimisation technique we try to optimise the different weld parameters and get a good quality of weld. We aim to develop a prototype 3-axis CNC Welding machine.

## III. COMPONENTS USED:

- Double acting pneumatic cylinders
- 5/2 Solenoid valve
- Rack and Pinion
- Metal frame
- Hoses and fittings
- Welding machine

## IV. METAL FRAME:

The metal frame is generally made of **mild steel** bars for machining, suitable for lightly stressed components including studs, bolts, gears and shafts. It can be case-hardened to improve wear resistance. They are available in bright rounds, squares and flats, and hot rolled rounds.

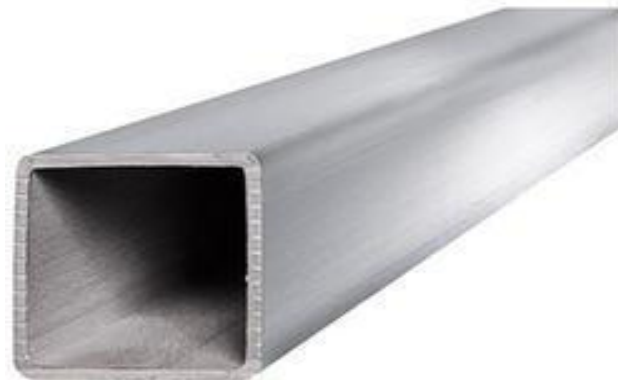

**Fig.2.Metal Frame**

Suitable machining allowances should therefore be added when ordering. It does not contain any additions for enhancing mechanical or machining properties. Bright drawn mild steel is an improved quality material, free of scale, and has been cold worked (drawn or rolled) to size. It is produced to close dimensional tolerances.

*Straightness and flatness are better than black steel. It is more suitable for repetition precision machining. Bright drawn steel has more consistent hardness, and increased tensile strength. Bright steel can also be obtained in precision turned or ground form if desired.*

## V. SOLENOID VALVE:

*A solenoid valve is an electromechanically operated valve. The valve is controlled by an electric current through a solenoid: in the case of a two-port valve the flow is switched on or off; in the case of a three-port valve, the outflow is switched between the two outlet ports. Multiple solenoid valves can be placed together on a manifold.*

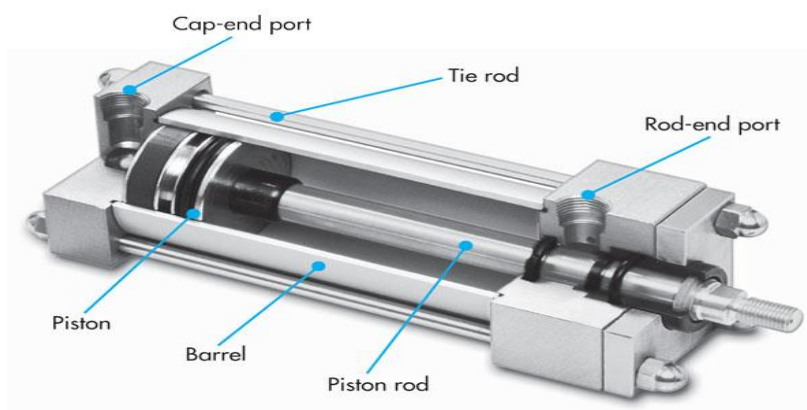

**Fig.3.Solenoid Valve**

*Solenoid valves are the most frequently used control elements in fluidics. Their tasks are to shut off, release, dose, distribute or mix fluids. They are found in many application areas. Solenoids offer fast and safe switching, high reliability, long service life, good medium compatibility of the materials used, low control power and compact design.*

## VI. DOUBLE ACTING PNEUMATIC CYLINDER:

*Double Acting Cylinders are equipped with two working ports- one on the piston side and the other on the rod side. To achieve forward motion of the cylinder, compressed air is admitted on the piston side and the rod side is connected to exhaust. During return motion supply air admitted at the rod side while the piston side volume is connected to the exhaust. Force is exerted by the piston both during forward and return motion of cylinder. Double acting cylinders are available in diameters from few mm to around 300 mm and stroke lengths of few mm up to 2 meters.*



**Fig.4.Double Acting Pneumatic Cylinder**

*Pneumatic actuators are the devices used for converting pressure energy of compressed air into the mechanical energy to perform useful work. In other words, Actuators are used to perform the task of exerting the required force at the end of the stroke or used to create displacement by the movement of the piston. The pressurised air from the compressor is supplied to reservoir. The pressurised air from storage is supplied to pneumatic actuator to do work. The air cylinder is a simple and efficient device for providing linear thrust or straight line motions with a rapid speed of response.*

*Friction losses are low, seldom exceeds 5 % with a cylinder in good condition, and cylinders are particularly suitable for single purpose applications and /or where rapid movement is required. They are also suitable for use under conditions which preclude the employment of hydraulic cylinders that is at high ambient temperature of up to 200 to 250 Their chief limitation is that the elastic nature of the compressed air makes them unsuitable for powering movement where absolutely steady forces or motions are required applied against a fluctuating load, or where extreme accuracy of feed is necessary. The air cylinder is also inherently limited in thrust output by the relatively low supply pressure so that production of high output forces can only be achieved by a large size of the cylinders.*

## **VII. WELDING MACHINE:**

*Arc welding is a process that is used to join metal to metal by using electricity to create enough heat to melt metal, and the melted metals when cool result in a binding of the metals. It is a type of welding that uses a welding power supply to create an electric arc between an electrode and the base material to melt the metals at the welding point. They can use either direct (DC) or alternating (AC) current, and consumable or non-consumable electrodes. The welding region is usually protected by some type of shielding gas, vapour, or slag. Arc welding processes may be manual, semi-automatic, or fully automated.*



**Fig.5.Welding Machine**

*To supply the electrical energy necessary for arc welding processes, a number of different power supplies can be used. The most common classification is constant current power supplies and constant voltage power supplies. In arc welding, the voltage is directly related to the length of the arc, and the current is related to the amount of heat input. Constant current power supplies are most often used for manual welding processes such as gas tungsten arc welding and shielded metal arc welding, because they maintain a relatively constant current even as the voltage varies.*

## **VIII. CONSTRUCTION:**

*The double axis welding machine will consist of following components:*

- 1. Double acting pneumatic cylinder*
- 2. Welding machine*
- 3. Rack and Pinion*
- 4. 5/2 Solenoid valve*
- 5. Metal frame*

The main aim of project is to fabricate the pneumatic operated welding machine. Welding is a fabrication process that joins materials, usually metals or thermoplastics. This is often done by melting the work pieces and adding a filler material to form a pool of molten material that cools to become a strong joint, with pressure sometimes used in conjunction with heat, or by itself, to produce the weld.

The pneumatic operation consists of pneumatic cylinder, compressor, control unit, solenoid valve etc... which are used to actuate the piston rod. The compressor is used to compress the air and it is passed to the solenoid valve. This solenoid valve controls the direction of flow of air to the cylinder. This pressurized air is actuating the piston rod to forward and return position. At the of piston rod the welding rod is fixed. This welding rod makes forward motion and reverse motion in order to make or weld the two different plates.

The welding rod is otherwise known as electrode which is connected to the power supply terminals. The work piece also connected to the power supply. This setup requires a heavy electrical arrangement to make the welding.

### IX. WORKING PRINCIPLE:

In our project "AUTOMATIC DOUBLE AXIS WELDING MACHINE" is beings with introduction to welding the various components automatically. Two pneumatic cylinders and Solenoid valve are provided. Cylinder is used for the forward and backward movement, it moves x and y axis that's why called double axis welding machine.

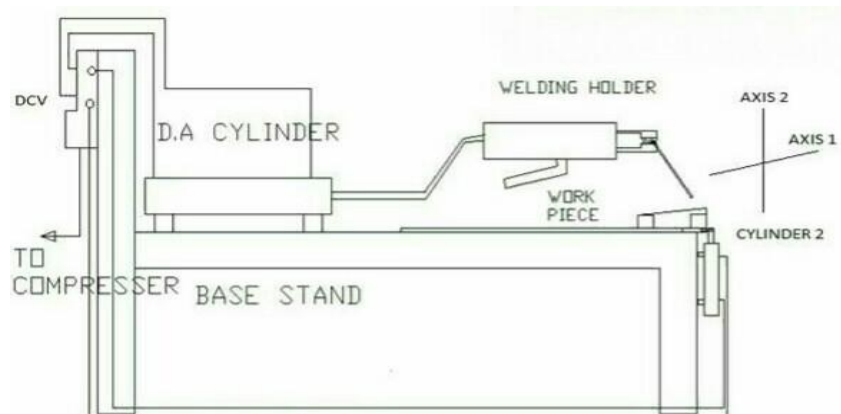

**Fig.6. Working Principle**

The Double axis welding machine makes use of properly shaped MS alloy electrodes in order to apply pneumatic pressure and carry electrical current through the work pieces. Heat is generated mainly at the merging point between two sheets. This causes the material being welded to melt gradually, thereby forming a molten bath, known as the weld mass. The molten bath is held through the pressure applied by the electrode tip and the encircling solid metal. If the compressed air goes to solenoid valve to pneumatic cylinder. welding holder connected to pneumatic cylinder which actuated by solenoid valve at the time automated welded for metal.

### X. ADVANTAGES:

- ✓ Small in size.
- ✓ Cost is less compared to other welding machine.
- ✓ Due to the nature of portable it can be easily handled.
- ✓ Due to portable ability it is easily handled.

- ✓ *Easy to operate*
- ✓ *Less maintenance*
- ✓ *Accuracy can be maintained.*

## **XI. APPLICATIONS:**

*There are many different uses of spot welding machines. Some of the areas where it finds application are:*

1. *Automobile industry*
2. *Automotive manufacturing*
3. *Metal working*
4. *Shipbuilding*
5. *Fabrication*
6. *Casting*
7. *Applicable for small scale industries*
8. *Workshops, etc,...*

## **XII. CONCLUSION:**

*This project is made with pre planning, that it provides flexibility in operation. This innovation has made the more desirable and Economical. This project "Fabrication of automatic pneumatic double axis welding machine" is designed with the hope that it is very much economical and help. This project helped us to know the periodic steps in completing a project work. Thus we have completed the project successfully.*

## REFERENCE:

- [1] K. Abbasi, S. Alam, and Dr. M.I. Khan, 2012, "An Experimental Study on the Effect of MIG Welding parameters on the Weld-Bead Shape Characteristics".
- [2] Jukka Martikainen Lic. and Raimo Suoranta , 2007, "Welding of sheet metal using modified short arc MIG/MAG welding process".
- [3] S. R. Patil and C. A. Waghmare, 2013, "Optimization of MIG welding parameters for improving strength of welded joints".
- [4] P. Kumari, K. Archana and R.S. Parmar, 2011, "Effect of Welding Parameters on Weld Bead Geometry in MIG Welding of Low Carbon Steel", *International Journal of Applied Engineering Research*
- [5] Satoshi Nakamura, Y. F., Y. Ikuno, Shinji Kodama and T. Maeda, 2005, "Automatic Control Technology of Welding Machine MAG-II for Onshore Pipelines".
- [6] Xu, Y. Li, J. Sun, and S. Wang, 2012, "Research and development of open CNC system based on PC and motion controller".
- [7] V.K. Pabolu and K.N.H. Srinivas, 2010, "Design and implementation of a three dimensional CNC machine".
- [8] B. Jayachandraiah, O. V., P. Abdullah Khan and R. A. Reddy, 2014, "Fabrication of Low Cost 3-Axis CNC Router".
- [9] J. Norrish, 2009, "Process control and automation developments in welding".
- [10] V. B. Bhandari, *Design of Machine Elements*, New Delhi: McGraw Hill, 2014.
- [11] PSG Design Data book, Coimbatore: Kalaikathir Achchangan, 2015.
- [12] Chavan D K, Pawar Udayan, Tambe Niharika and Sane Abhishek. *Design of Three Axis Pick and Place Mechanism for Friction Welding Machine to Reduce the Time Cycle and to Increase Productivity. International Journal of Design and Manufacturing Technology (IJDMT)*.5 (1), 2014, pp. 12-22.