

Power Flow Management Of A Grid-Connected Hybrid Pv Wind Battery Based System With An Efficient Multi Input Transformer Coupled Bidirectional Dc-Dc Converter

Vasanki Shailaja

Assistant Professor, Department of Electrical and Electronics Engineering
KG Reddy College of Engineering and Technology, Moinabad, Hyderabad, India

Abstract: The main aim of this project is a control strategy for power flow management of a grid-connected hybrid PV-wind-battery based system with an efficient multi-input transformer coupled bidirectional-dc converter is presented. The proposed system aims to satisfy the load demand, manage the power flow from different sources, inject surplus power into the grid and charge the battery from grid as and when required. A transformer coupled boost half-bridge converter is used to harness power from wind, while bidirectional buck-boost converter is used to harness power from PV along with battery charging/discharging control. A single-phase full-bridge bidirectional converter is used for feeding ac loads and interaction with grid. The proposed converter architecture has reduced number of power conversion stages with less component count, and reduced losses compared to existing grid-connected hybrid systems. This improves the efficiency and reliability of the system.

Keywords: PV, DC-DC Converter, Battery, Wind, Hybrid system, MPPT.

I. INTRODUCTION

Solar photovoltaic (PV) and wind have emerged as popular energy sources due to their co friendly nature and cost effectiveness. Hence, it is a challenge to supply stable and continuous power using these sources. This can be addressed efficiently integrating with energy storage elements. The interesting complementary behavior of solar insolation and wind velocity Patten coupled with the above mentioned advantages, has led to their integration resulting in the hybrid PV wind systems. For achieving the integration of multiple renewable sources, The traditional approach involves using dedicated single input converters one for each source, which are connected to a common dc bus .However converters are not effectively utilized ,due to the intermit ten nature of the renewable sources. In addition, there are multiple power conversion stages which reduce the efficiency of the system. Significant amount of literature exists on the integration of solar and wind energy as a hybrid energy generation system with focus mainly on its sizing and optimization. In the sizing of generators in a hybrid system is integrated. In this system, the sources and storage are interfaced at the dc-link, through their dedicated converters. Other contributions are made on their modeling aspects and control techniques for a stand-alone hybrid energy system.

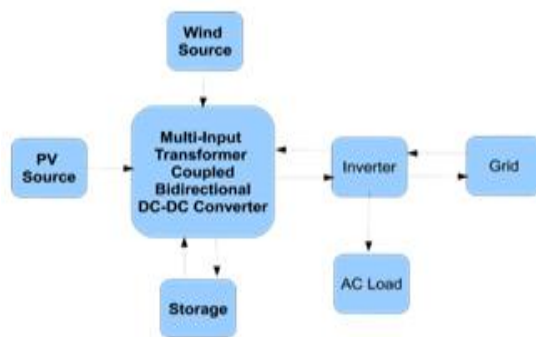

Fig.1.Grid-connected hybrid PV-wind-battery based system for household applications.

Many topologies are proposed and they can be classified into three groups, non-isolated, fully-isolated and partially-isolated multi-port toologies. All the power ports in non-isolated multi-port topologies share a common ground. However, the power components cannot be shared. All the topologies in non-isolated multi port are mostly combinations of basic to pology units, such as the buck, the boost, the buck-boost or the bidirectional buck/boost topology unit. These time-sharing based multi-port topologies promise low-cost and easy implementation. However, a common limitation is that power from multiple inputs cannot be transferred simultaneously to the load. Further, matching wide voltage ranges will be difficult in these circuits. This made there searchers to prefer isolated multi-portconverterscomparedtonon-isolatedmulti-portdc-dcconverters. The magnetic

coupling approach is used to derive a multiport converter, where the multi-winding transformer is employed to combine each terminal. In fully isolated multi-port dc-dc converters, the half-bridge, full-bridge, and hybrid- structure based multi-port dc-dc converter switch a magnetic coupling solution can be derived for different applications, power, voltage, and current levels.

II. PROPOSED CONVERTER CONFIGURATION

The proposed converter consists of a transformer coupled boost dual-half-bridge bidirectional converter fused with bidirectional buck-boost converter and a single-phase full-bridge inverter. The proposed converter has reduced number of power voltage boosting are accomplished through a single converter. The proposed converter has reduced number of power conversion stages with less component count and high efficiency compared to the existing grid-connected converters. The power flow from wind source is controlled through a unidirectional boost half-bridge converter. For obtaining MPP effectively; smooth variation in source current is required which can be obtained using an inductor. In the proposed topology, an inductor is placed in series with the wind source which ensures continuous current and thus this inductor current can be used for maintaining MPP current. When switch T3 is ON, the current flowing through the source inductor increases. The capacitor C1 discharges through the transformer primary and switch T3 as shown in Fig2. In secondary side capacitor C3 charges through transformer secondary and anti-parallel diode of switch T5. When switch T3 is turned OFF and T4 is turned ON, initially the inductor current flows through anti-parallel diode of switch T4 and through the capacitor bank. The path of current is shown in Fig. During this interval, the current flowing through diode decreases and that flows through transformer primary increases. When current flowing through the inductor becomes equal to that flowing through transformer primary, the diode turns OFF. Since, T4 is gated ON during this time, the capacitor C6 now discharges through switch T4 and transformer primary. During the ON time of T4, anti-parallel diode of switch T6 conducts to charge the capacitor C4. The path of current flow is shown in Fig. During the ON time of T3, the primary voltage $V_p = -VC_1$.

The secondary voltage $V_s = nV_p = -nVC_1 = -VC_3$, or $VC_3 = nVC_1$ and voltage across primary inductor L_w is V_w .

When T3 is turned OFF and T4 turned ON, the primary voltage $V_p = VC_6$. Secondary voltage $V_s = nV_p = nVC_6 = VC_4$ and voltage across primary inductor L_w is $V_w = (VC_1 + VC_6)$. Conversion stages with less component count and high efficiency compared to the existing grid-connected schemes.

In the proposed configuration as shown in Fig2. a bidirectional buck-boost converter is used for MPP tracking of PV array and battery charging/discharging control. Further, this bidirectional buck-boost converter charges/discharges the capacitor bank C1-C6 of transformer coupled half-bridge boost converter based on the load demand. The half-bridge boost converter extracts energy from the wind source to the capacitor bank C1-C6. During battery charging mode, when switch T1 is ON, the energy is stored in the inductor L. When switch T1 is turned OFF and T6 is turned ON, energy stored in L is transferred to the battery. If the battery discharging current is more than the PV current, inductor current becomes negative.

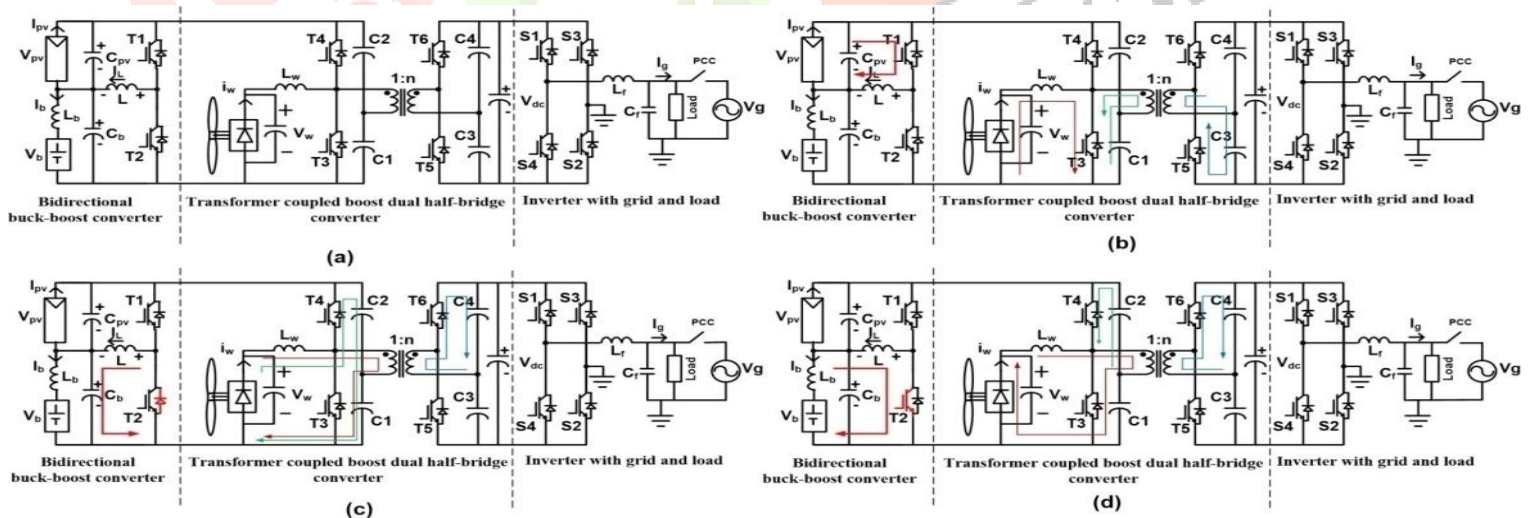

Fig.2. Operating modes of proposed multi-input transformer coupled bidirectional dc-dc converter. (a) Proposed converter configuration. (b) Operation when switch T3 is turned ON. (c) Operation when switch T4 ON, charging the capacitor bank. (d) Operation when switch T4 ON, capacitor C6 discharging.

III. HYBRID SYSTEMS

Solar Wind Hybrid Systems are powered by sun and wind, in order to guarantee that the power is enough to be charged in the solar battery every day. If on some days there is sunlight but no wind energy, the solar panel charges the battery. If on some days there is wind energy but no sunlight, the wind turbine charges the power to the battery. When both wind and solar energy are sufficient, both charge the battery. By doing so the variability of a single source (i.e., wind or sun beam) can be softened.

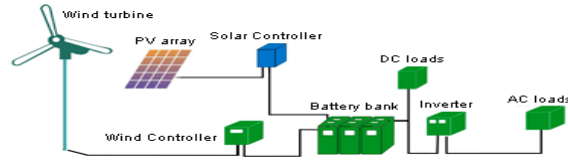

Figure 3. Wind / Solar PV Hybrid Systems Include

- PV Array:** A number of PV panels connected in series and/or in parallel giving a DC output out of the incident irradiance. Orientation and tilt of these panels are important design parameters, as well as shading from surrounding obstructions.
- Wind turbine:** which is installed on top of a tall tower, collects kinetic energy from the wind and converts it to electricity that is compatible with a home's electrical system?
- Solar controller:** control battery bank charge and discharge reasonable and safety.
- Battery bank:** can be a single battery or multiple batteries connected together to create essentially one large battery of the required voltage and amp-hour capacity. In some ways the battery configuration and capacity are the most important electrical power decision to make, and a wise choice can help guarantee a steady supply of electrical power as well as a system that is simple to operate and maintain.
- Inverter:** A power converter that "inverts" the DC power from the panels into AC power.
- Loads:** Stands for the network connected appliances in the building that are fed from the inverter (AC loads), or from the battery bank (DC loads).

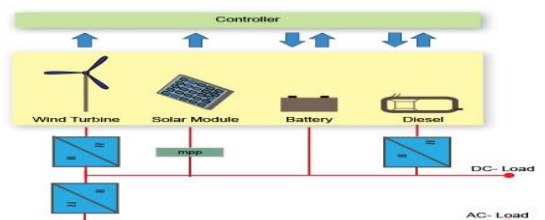

Figure 4. Typical grid tie, wind, solar PV hybrid diagram:

P & O Method

The Perturbation and Observation Method (P&O) is one of the most popular MPPT methods because of its simplicity. The P&O method operates by making small incremental changes in voltage and measuring the resulting change in power. By comparing the current power measurement to the previous power measurement, the P&O method selects the direction for the next perturbation.

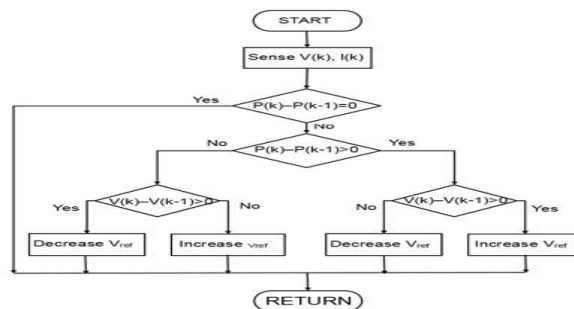

Fig 5. Flow chart of P & O Method

IV.SIMULATION RESULTS

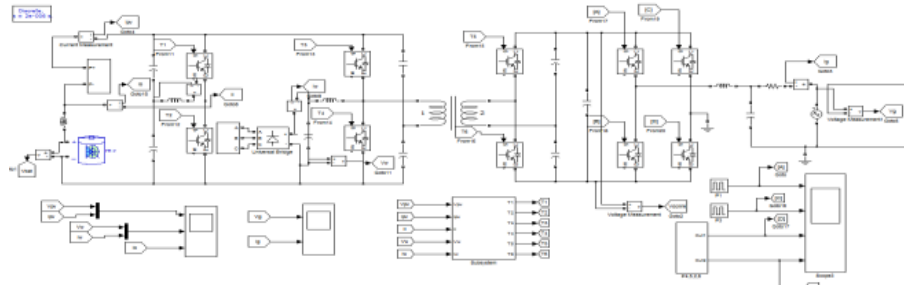

Fig 6: SIMULINK Circuit of PV WIND BATTERY Storage Circuit

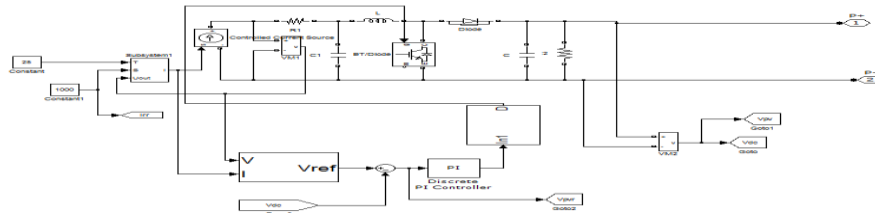

Fig 7: Indicates the SIMULINK PV Systems

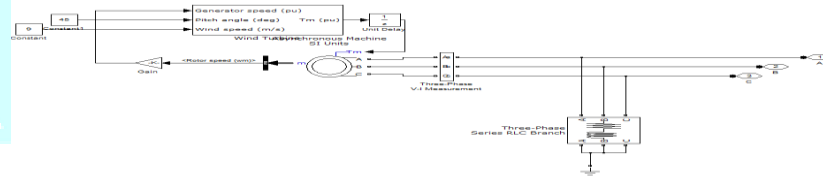

Fig 8: Indicates the simulink of Wind Energy System

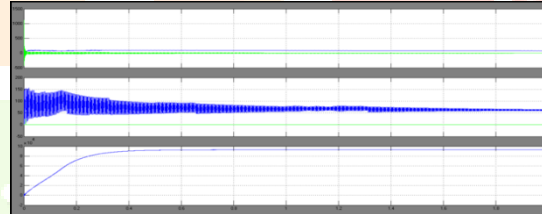

Fig 9. Steady state operation in MPPT mode Vpv , Ipv, Vw, Iw, Ib.

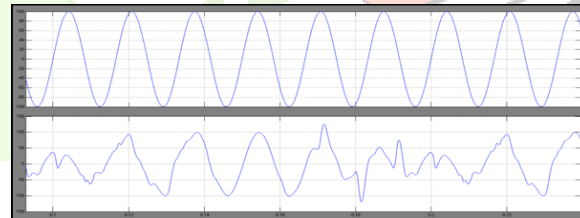

Fig 10. Steady state operation in MPPT mode. Vg and Ig.

ADVANTAGES

- explores a multi-objective control scheme for optimal charging of the battery using multiple sources.
- Supply's un-interruptible power to loads.
- Ensuring evacuation of surplus power from renewable sources to the grid, and charging the battery from grid as and when required.

APPLICATIONS

A grid-connected hybrid PV-wind-battery based power evacuation scheme can also use for household application.

V. CONCLUSION AND FUTURE WORK

A grid-connected hybrid PV-wind-battery based power evacuation scheme for household application is proposed. The proposed hybrid system provides an elegant integration of PV and wind source to extract maximum energy from the two sources. It is realized by a novel multi-input transformer coupled bidirectional dc-dc converter followed by a conventional full-bridge inverter. A versatile control strategy which achieves better utilization of PV, wind power, battery capacities without effecting life of battery and power flow management in a grid-connected hybrid PV-wind-battery based system feeding ac loads is presented. Detailed simulation studies are carried out to ascertain the viability of the scheme. The simulation results obtained are in close agreement with simulations and are supportive in demonstrating the capability of the system to operate either in grid feeding or stand-alone mode. The proposed configuration is capable of supplying un-interruptible power to ac loads, and ensures evacuation of surplus PV and wind power into the grid.

REFERENCES

- [1] F. Valenciaga and P. F. Puleston, "Supervisor control for a stand-alone hybrid generation system using wind and photovoltaic energy," *IEEE Trans. Energy Convers.*, vol. 20, no. 2, pp. 398-405, Jun. 2005.
- [2] C. Liu, K. T. Chau and X. Zhang, "An efficient wind-photovoltaic hybrid generation system using doubly excited permanent-magnet brushless machine," *IEEE Trans. Ind. Electron.*, vol. 57, no. 3, pp. 831-839, Mar. 2010.
- [3] W. Qi, J. Liu, X. Chen, and P. D. Christofides, "Supervisory predictive control of standalone wind/solar energy generation systems," *IEEE Trans. Control Sys. Tech.*, vol. 19, no. 1, pp. 199-207, Jan. 2011.
- [4] F. Giraud and Z. M. Salameh, "Steady-state performance of a grid connected rooftop hybrid wind-photovoltaic power system with battery storage," *IEEE Trans. Energy Convers.*, vol. 16, no. 1, pp. 1-7, Mar. 2001.
- [5] S. K. Kim, J. H. Jeon, C. H. Cho, J. B. Ahn, and S. H. Kwon, "Dynamic modeling and control of a grid-connected hybrid generation system with versatile power transfer," *IEEE Trans. Ind. Electron.*, vol. 55, no. 4, pp. 1677-1688, Apr. 2008.

