

# SOLAR ENERGY REAPING MACHINE FOR WIRELESS SENSOR NETWORKS

<sup>1</sup>Arpita Sharma, <sup>2</sup>Ashish Jaiswal, <sup>3</sup>Harish Kumar Maheshwari  
<sup>1</sup>M.Tech Scholar (DC), <sup>2,3</sup>Assistant Professor

<sup>1, 2, 3</sup> Rajasthan Institute of Engineering & Technology, Bhankrota, Ajmer Road, Jaipur- 302026

**Abstract:** Now a days, Wireless Sensor Networks (WSNs) are used in many application areas, ranging from health and life style to automobile, smart building, active RFID tags. Energy reaping machine and management is the most suitable ways to solve the problem of making WSN autonomous and enable widespread use of these systems in many applications. Out of various energy sources, solar radiation energy is available everywhere and accomplish the power necessity of WSN. Thus, a solar energy reaping machine is introduced for low powered wireless sensor networks. In this paper, energy reaping machine module and a solar energy reaping machine which composed of a solar panel is introduced. This idea works on the principle of photo voltaic effect.

Solar PV is technology which draws upon the planet's most plentiful and widely distributed renewable energy source

the sun. The direct conversion of sunlight to electricity happens without any moving parts or environmental emissions during operation. Now a day, after hydro and wind power, solar PV is the third most important renewable energy source in terms of globally installed capacity. Solar PV is used in More than 100 countries.

**Keywords:** Boost converter, WSN, EnerChip EH Module, PV system, Rechargeable storage batteries.

## 1. INTRODUCTION

In the world, wireless sensor network (WSN) is the second largest network after the Internet and in next ten emerging technologies it ranks as first. Currently, Internet of Things (IOT), mainly for environmental parameter monitoring various production circumstances, such as greenhouse, water quality monitoring and so on, it has been used widely. Energy harvesting and management may be the most convenient ways to solve the problem of making WSN autonomous and enable widespread use of these systems in many applications.

Conventionally, ordinary batteries can be considered as power source in WSN, where researchers have made efforts to save the finite battery on power control by routing algorithm and topology optimization. The available battery technology the most up-to-date power density, cannot match the most of need WSN for long lifetime and small size form factor, which limits the use of WSN due to the need of large batteries.

In many applications Energy harvesting and management may be the most efficient ways to solve the problem of making WSN autonomous and enable wide spread use of these system. Energy-harvesting systems state-of-art energy-storage techniques in WSNs can be classified into two technologies, i.e., super capacitors and rechargeable batteries. Since the super capacitors have significantly lower power density and higher leakage overhead than rechargeable batteries, which makes them impractical for small-package WSN nodes, using a lithium battery as the storage we employ an energy-harvesting system.

The energy which is produced by sun is termed as Solar Energy and it is being produced in a dreadful amount in the range of trillion watt hours. It is said that with just 0.1% of energy whole world demands will be met. It is dreadfully being in progress to get some better process for harnessing the energy from the sun.

As paper focuses on a solar energy reaping machine which works on the principle of photovoltaic effect and composed of a solar panel and energy mowing module. This harvested is used to charge the EnerChip batteries in the EH module. The battery supplies sufficient power to WSN to communicate the integrated temperature

and RF signal strength information of

environment at end point or WSN to the access point.

#### A. Block Diagram of Energy Reaping machine for WSN

A block diagram of Solar Energy Reaping machine Module is shown in Fig.1 which consists of:

- Input Power Transducer
- Boost Converter
- Charge Controller
- Rechargeable Energy storage batteries (EnerChip CBC050)
- Power Management Block
- Wireless Sensor Network

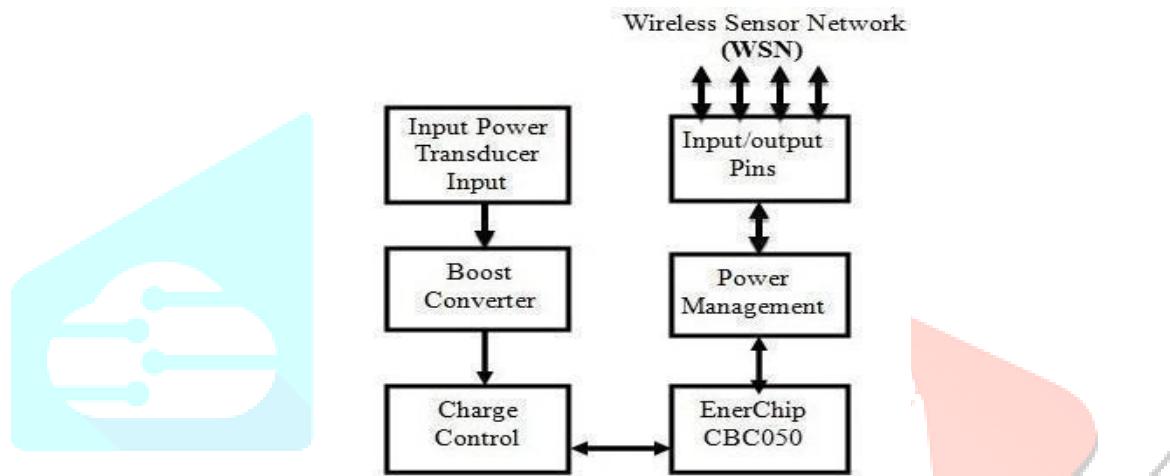

Fig.1. Block diagram of Energy Reaping machine for WSN

#### 1. Input Power Transducer

CBC5300 will operate with many transducer types. To work with transducers having output impedance over the range of  $58\Omega$  to  $4k\Omega$  and an input voltage over the range of  $270mV$  to  $1.5V$  the CBC5300 module is designed. To start the operation the minimum open circuit voltage required is  $700mV$ . The solar panels, wind turbines, thermoelectric generators, piezoelectric transducers etc. these are the available input power transducers

#### 2. Boost Converter

To increase the voltage from the solar cell to a sufficient level to charge the thin-film battery and run the rest of the system a boost converter is used. A boost converter is a DC-to-DC power converter which is used to step up voltage (while stepping down current) with its input (supply) to its output (load). This is a class of switched-mode power supply (SMPS) that contains at least two semiconductors (a transistor and a diode) and at least one energy storage element, capacitor, inductor, or two in combination.

#### 3. Charge Controller

The output of the boost converter continuously monitors by the Charge Control block. If the output of the boost converter falls down the voltage needed to charge the EnerChip, the charge controller disconnects the boost converter from the system to inhibit back powering the boost converter in low light conditions.

#### 4. Power Management Block

The Power Management block inhibits the EnerChip from discharging too deeply in low-light conditions or under abnormally high current loads. The Power Management block has a control line, CHARGE, which indicates to the MSP430 that the EnerChip is actively charging by the solar energy reaping machine.

### 5. Rechargeable Storage Batteries (EnerChip CBC050)

The Energy Harvesting Module structures two EnerChip batteries mounted on the board with a 100-mAhr capacity and during wireless transmissions for a 1,000-mF capacitor for high-current pulses. Using the power management status and control signals on the SEH-01, to maximize the lifetime of the overall system the firmware on the MSP430 has been written to make the application 'Energy Aware'.

### 6. Wireless Sensor Networks

A WSN usually consists of tens to thousands of such nodes. To sharing the information and cooperative processing the nodes communicate through wireless channels. WSNs can be deployed on a global scale for environmental monitoring and habitat study, reconnaissance and military surveillance over a battle field, in contingent environments for search and rescue, in factories for condition based maintenance, in buildings for infrastructure monitoring, in homes to realize smart homes, or even in hospitals for patient monitoring.

## II. ENERGY HARVESTING TECHNIQUES

### A. Introduction

Energy harvesting techniques are converting an indirectly usable form of energy to electrical energy sufficient to power unattended and usually low power systems. Examples of such systems are wireless sensors, structure-embedded instrumentation, military monitoring devices, biomedical implants, Bluetooth headsets, calculators, watches, in 2009 Nokia announced it is developing a mobile prototype that could harvest energy from extensive radio waves emitted from mobile antennas, TV poles and other sources (Nokia hopes to create a device that could harvest enough power to keep a cell phone topped up). Energy harvesting technique used in this paper is solar energy because it is easily available throughout the world.

### B. Solar Energy

Solar energy is a device that converts light energy into electrical energy. Solar cells are used to generate electricity from sunlight. While the term photovoltaic cell is used when the light source is unspecified. The free electrons energizes by the radiant energy, when the PV cell is placed in the sun. If a circuit is made by connecting the top and bottom of the silicon wafer with wire, electrons flow from n-type to p-type through the wires.

## III. SOLAR ENERGY HARVESTING MODULE

### A. Introduction

To receive a wide range of energy transducer inputs, store the harvested power, and deliver achieved power to the target system the EnerChip module is designed. To enable system designers to quickly develop Energy Harvesting applications it is the purpose of this module.

### B. System Description

The schematic of the EnerChip EH CBC5300 energy harvesting module is shown in Fig.2. It has two CBC050 50 $\mu$ Ah EnerChip rechargeable battery cells, total capacity is 100 $\mu$ Ah.

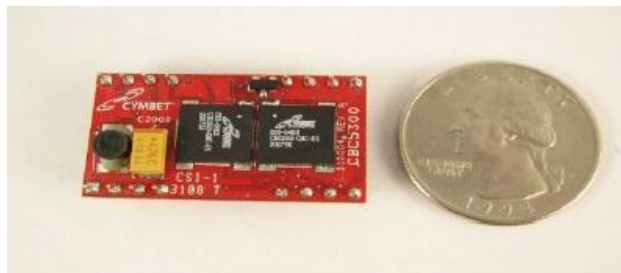

Fig.2. EnerChip EH Module - CBC5300

The energy harvesting transducer (e.g. photovoltaic cell, piezoelectric material, etc.) converts ambient energy into electrical energy. Generally, the transducer is used to convert one form of energy into another form of energy. The output voltage of the energy harvesting transducer is very low so that it could not charge the EnerChip batteries and power the rest of the system directly, that's why we used boost converter to boost the voltage of energy harvesting transducer.

#### IV. WIRELESS SENSOR NETWORKS

A wireless sensor network containing of spatially distributed autonomous devices. Sensors are used to monitor the physical or environmental conditions. The wireless protocol that we use in it they depends upon the application requirements. A WSN usually consists of tens to thousands of such nodes. To sharing the information and cooperative processing the nodes communicate through wireless channels. WSNs can be deployed on a global scale for environmental monitoring and habitat study, reconnaissance and military surveillance over a battle field, in contingent environments for search and rescue and many more things. Some of the standard radio, which are usually consist 2.4 GHz and possessory radio consist 900MHz. WSNs are especially suitable for large scale deployments in various environments due to the advantages of high flexibility, low cost and comfort maintenance. Therefore, they can be used in many different-different applications including vehicle tracking, habitat and structural monitoring and etc.

##### A. WSN Architecture

The most common WSN architecture follows the OSI model. The WSN OSI model includes five layers (namely application layer, transport layer, network layer, data link and physical layer) and three cross layer (namely power management, mobility management and task management). These layers are used to fulfill the network and make the sensor work together in order to increase the efficiency of the network.

Fig.3 shows the architecture of wireless sensor network. To connect single user interface with multiple sensors the power of wireless leverage by the WSN system. The WSN system performances as a data acquisition and smart control over various sensors. Over the internet system allows access to the sensors from remote online locations.

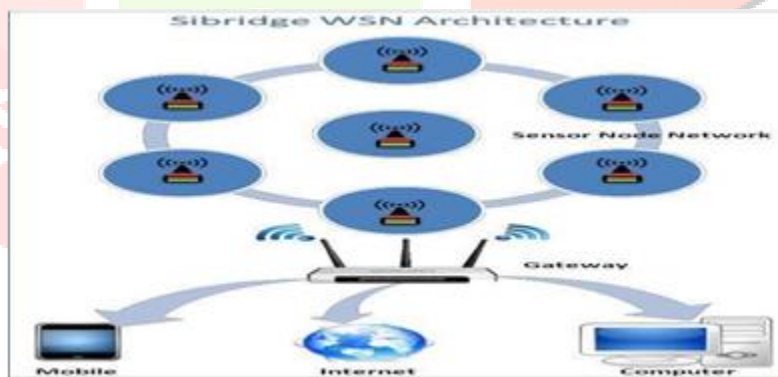

Fig.3. WSN Architecture

WSN node is very small, has very low power and low cost module. These WSN node can connects with one or more than one nodes easily and it works independently. WSN node has sensors or actuators, with the help of wireless interfaces(like Wi-Fi, Bluetooth or Zigbee) these sensors can be monitored or controlled. WSN node can be configured for different wireless interfaces, sensors and actuators.WSN programming carries the following benefits, topologies and modes.

##### B. Communication In A WSN

In 1997 the well-known IEEE 802.11 family of standards was introduced and for the mobile system. It is the most common wireless networking technology. It was frequently used in early

WSNs and still be found in current networks when the bandwidth requisition are high (e.g., for multimedia sensors). It uses different frequency bands, for example, IEEE 802.11b and IEEE 802.11g uses the 2.4-GHz band, while the IEEE 802.11a protocol uses the 5-GHz frequency band. However, the high-energy overheads of IEEE 802.11-based networks make this standard unsuitable for low-power sensor networks. The bandwidths provided by dial-up modems are comparable with typical data rate requirements in sensor networks, therefore the data rates provided by IEEE 802.11 are typically much higher than needed.

## V. SOFTWARE

There are two different evolution software tools in the form of TI: IAR Embedded Workbench Kick Start and Code Composer Studio (CCS). The term "Kick Start" refers to the limited version of Embedded Workbench that allows up to 4KB of C-code anthology.

The eZ430-RF2500 shown in fig.4 It is a complete USB-based MSP430 wireless development tool providing for the all hardware and software to evaluate the MSP430F2274 microcontroller and CC2500 2.4GHz wireless transceiver.

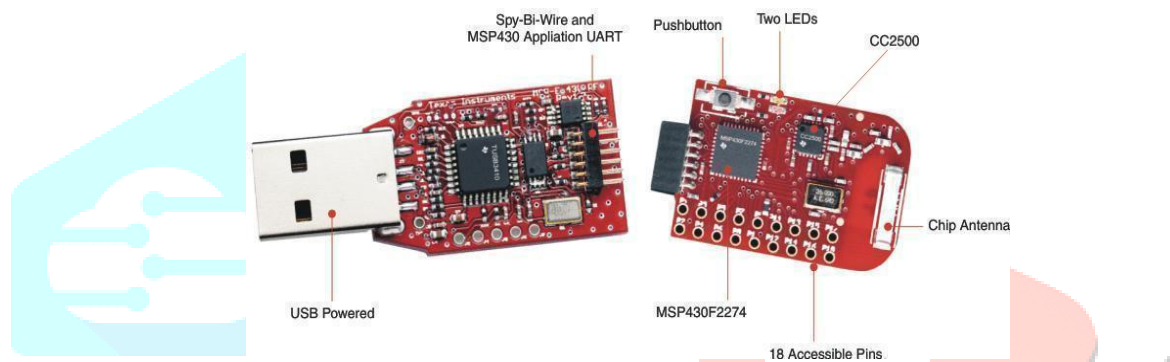

Fig.4. eZ430-RF2500

The hardware includes:

- Two eZ430-RF2500T target boards
- One eZ430-RF USB debugging interface
- One AAA battery pack with expansion board (batteries included)

As a stand-alone development tool the eZ430-RF2500 is used. Additionally, the eZ430-RF2500T target board also may be separate from the debugging interface and integrated into another design by removing the plastic enclosure. Most of target board pins are easily accessible.

### A .Software Installation

There are two different evolution software tools in the form of TI: IAR Embedded Workbench Kick Start and Code Composer Studio (CCS). The term "Kick Start" refers to the limited version of Embedded Workbench that allows up to 4KB of C-code anthology. The network protocol is a proprietary, low-power radio-frequency (RF) protocol targeting simple, small RF networks (<100 nodes).

## VI. RESULTS

The Sensor Monitor PC application is a graphical representation of the star network and shows the sampled data of the each wireless device. The Access Point is known as the center node and this is attached to the End Devices, which display their voltage, temperature, and their transmission frequency. By adding more wireless nodes in the network the number of End Devices can be expanded.



Fig.5. WSN data displayed at access point

As the target board connected to the solar reaping module, a node will connect to the access point on the desktop as shown in fig.5. The colour of the node will be in yellow, if the power is taking from the light source and the colour of node will be blue, then it is running by battery power. The distance between the node (End device) and the access point is less which indicates area were the node is located. It also provides the temperature at the end device and the access point.



Fig.6. WSN data displayed with increased distance from access point

Fig.6 shows that the distance of end device is increased which decreases temperature at end point.



Fig.7. WSN data displayed when node powered with battery

Fig.7 shows the input from the transducer is not enough to drive the WSN. So, the node (End device) works on battery power, which is identified when the node is blinking in blue colour.

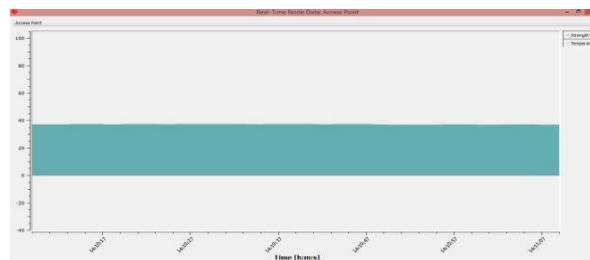

Fig.8. Signal strength at access point which receives power from PC

Fig.8 shows the signal strength from the access point and temperature. Since the signal from access point is received through USB there is no variation in it.

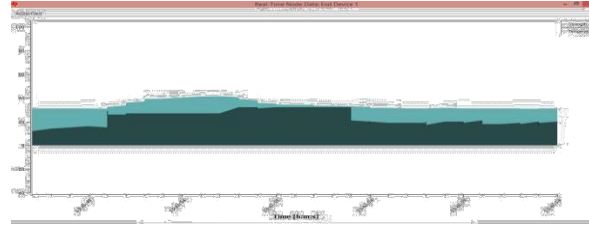

Fig.9. Signal strength at end point or WSN

Fig.9 shows the temperature and signal strength of the WSN. Since the readings are taken at different locations signal strength and temperature is varied.

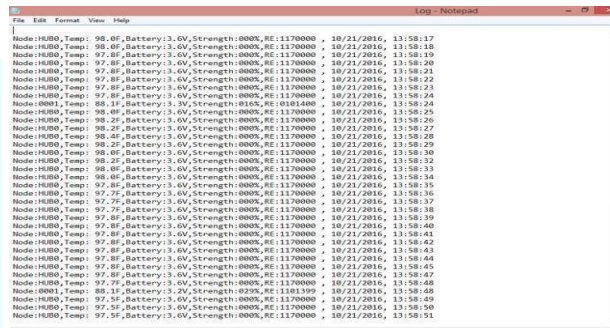

Fig.10. Data logging from various WSNs

Fig.10 shows that to view the real-time data of all nodes in text format the console window is used.

## VII. CONCLUSION

In this paper, a solar energy-reaping machine system is evolved and knowledge at WSN is monitored from the access point. The solar energy reaping machine module includes a high-efficiency solar panel optimized for operating indoors under low-intensity lights, which supplies enough power to run a low-power wireless sensor application. The energy coming from the sun to be a better source for harnessing. Solar energy is the best means for energy and it helps us in storing as well as using it as prisoner power. The system as well manages and stores additional energy in a pair of thin-film rechargeable EnerChips, capable of delivering enough power at 3.5-3.6V to drive WSN and for more than 400 transmissions from a single charge. To use the microcontroller and wireless transceiver provides all of the necessary hardware and software. With the help of this hardware and software integrated temperature and RF signal strength indicators monitored the environment at WSN from access point.

## REFERENCES

- [1] ZhouY, Yang X, Guo X, et al. A design of greenhouse monitoring & control system based on ZigBee wireless sensor network. IEEE. Int. Conf. WiCOM, (IEEE, Shanghai, 2007), pp. 2563–2567
- [2] Ahonen T, Virrankoski R, Elmusrati M. Greenhouse monitoring with wireless sensor network. IEEE/ASME. Int. Conf. on MESA, (IEEE/ASME, Beijing, 2008), pp. 403–408
- [3] Nasser N, Zaman A, Karim L, et al. CPWS: An efficient routing protocol for RGB sensor - based fish pond monitoring system. IEEE. 8th. Int. Conf. WiMob, (IEEE, Barcelona, 2012), pp. 7–11
- [4] O'Flynn B, Martinez R, Cleary J, et al. Smart Coast: a wireless sensor network for water quality monitoring. IEEE. 32nd. Conf. LCN. 2007;815–816.