

Improvement of Voltage Profile and Reduction of Power Losses by Optimal Placement of TCSC device by using GA

¹Tushar Agarwal, ²Amarpreet singh
¹ Assistant Professor, ² Assistant Professor
¹ Electrical Engineering Dept.
²Electrical Engineering Dept. Jaipur, India

Abstract : Flexible Alternating Current Transmission Systems (FACTS) devices have been proposed to be effective for controlling power flow and regulating bus voltage in electrical power systems, resulting in an increased power transfer capability, low system losses. Voltage variations can be stabilized and controlled by providing required reactive power. The low voltages reduce the power transfer through the transmission lines and may lead to Instability. Hence FACTS Controllers are widely used in Interconnected Power Systems to control the voltage levels within the tolerable limits. Placement of these devices in suitable location can lead to control in line flow and maintain bus voltages in desired level and so improve voltage stability margins.

This paper presents the GA optimization technique to find optimal location of TCSC device for reduction of power losses so thereby improves the voltage profile of the power system network. The optimizations are performed on two parameters: the location of the devices, and their values. The results are compared with and without the TCSC device. To show the validity of the proposed techniques and for comparison purposes, simulation carried out on an IEEE- 30 Bus test system.

IndexTerms - reactive power control, TCSC, stability, GA

I. INTRODUCTION

As the load increases, power utilities are looking for ways to maximize the utilization of their existing transmission systems, therefore controlling the power flow in the transmission lines is an important issue in planning and operating of power system. FACTS technology has become a very effective means to improve capacity of existing power transmission network without the necessity of adding new transmission lines. These devices control the power flow by reducing the power flow in overloaded lines and reduce line losses [1-3]. To achieve good performance of these devices it is important to ascertain their location because of their significant costs. By using FACTS devices, it is also possible to control the phase angle, the voltage magnitude at chosen buses and/or line impedances of transmission system [4]. There are several strategies have been proposed and implemented, these are based on the optimization of single objective like static voltage stability enhancement [5-8], violation diminution of the line thermal constraints [9], network loadability enhancement [10, 11], loss reduction [12], voltage profile improvement [9], power plants fuel cost reduction using optimal power flow [13], and economical approach which has minimized the overall system cost function [14]. For minimization of losses the rating and location have to be determined simultaneously. This concurrent optimization can be done with genetic algorithm.

This paper presents a genetic based method to seek the rating and best location of FACTS controllers to improve voltage profile and to reduce power losses.

II. PROBLEM FORMULATION

To find out the optimal location and rating of TCSC, the objective function used is minimization of losses.

2.1 Objective Functions

The objective is to minimize the system losses

$$\min Fl = \sum_{K=1}^{nl} PL_{il}$$

Where

Fl = Objective function to minimize active power losses.

ntl = Number of transmission lines in the system.

$PLtl$ = Active power loss in tl^{th} line.

$$PL_{tl} = \sum_{K=1}^{nb} G_K \sqrt{V_i^2 + V_j^2 - 2V_i V_j \cos(\delta_i - \delta_j)}$$

2.2 Problem Constraints

Equality Constraint

These constraints represent load flow equations are

$$P_{Gi} - P_{Di} - V_i \sum_{j=1}^{nl} V_j (G_{ij} \cos \theta_{ij} + B_{ij} \sin \theta_{ij}) = 0$$

$$Q_{Gi} - Q_{Di} - V_i \sum_{j=1}^{nl} V_j (G_{ij} \sin \theta_{ij} - B_{ij} \cos \theta_{ij}) = 0$$

$i = 1, 2, \dots, nb$ no. of buses

P_{Gi} = Generator real power

Q_{Gi} = Generator reactive power

P_{Di} = Demanded real power

Q_{Di} = Demanded reactive power

G_{ij} = Transfer conductance

B_{ij} = Transfer susceptance

Inequality Constraints

These represent the system operating conditions such as generator voltage V_G , generator reactive power output Q_G , transformers tap T , switchable VAR compensations Q_C and load voltages V_L .

$$V_{Gi}^{\min} < V_{Gi} < V_{Gi}^{\max}$$

$$Q_{Gi}^{\min} \leq Q_{Gi} \leq Q_{Gi}^{\max} \quad i = 1, 2, \dots, NG$$

$$T_i^{\min} \ll T_i \ll T_i^{\max} \quad i = 1, 2, \dots, NT$$

For TCSC

$$-0.7X_L \leq X_{TCSC} \leq 0.7X_L$$

Where

$$0.9 \ll T_i \ll 1.0$$

$$0.95 \ll V_{Li} \ll 1.05$$

III. MODELLING OF TCSC

Thyristor Controlled Series Capacitor (TCSC) is a series FACTS device which allows rapid and continuous changes of the transmission line impedance. It has great application potential in accurately regulating the power flow on a transmission line, damping inter-area power oscillations, mitigating sub synchronous resonance (SSR) and improving transient stability. The characteristics of a TCSC at steady state and very low frequencies can be studied using fundamental frequency analytical models.

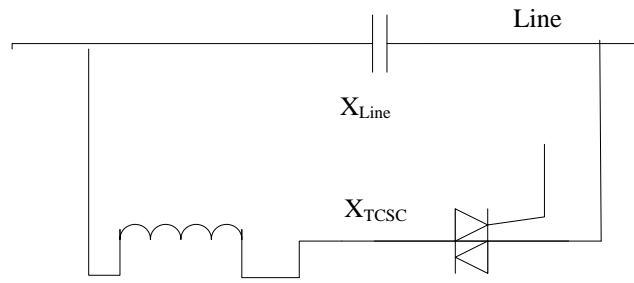

Fig.1. Model of TCSC

In this paper TCSC is modeled by changing transmission line reactance as below:

$$X_{ij} = X_{line} + X_{TCSC}$$

$$X_{TCSC} = r_{TCSC} \cdot X_{line}$$

Where X_{line} is reactance of transmission line and r_{TCSC} is compensation factor of TCSC. Rating of TCSC is depended on transmission line where it is located. To prevent overcompensation, TCSC reactance is chosen between $-0.7 X_{line}$ to $0.7X_{line}$ [15].

IV. PROPOSED ALGORITHM

The aim of the optimization is to find the best location of FACTS devices to optimize certain objectives. In this paper we use genetic algorithm optimization technique taking location, type and rating as variables. Genetic algorithms are computerized search optimization algorithm based on the theory of natural selection [16]. An individual is represented with three strings of length. The first string represents the values of the devices. It can take discrete values between 0 and 1, 0 corresponding to the minimum value of the device and 1 to the maximum. According to the model of the FACTS, the real value of the device is calculated with the relation.

$$V_{REALF} = V_{MINF} + (V_{MAXF} - V_{MINF})$$

Where V_{MINF} and V_{MAXF} are respectively the minimum and maximum set value of the device, and is its normalized value. The second string is related to the kind of the devices. A value is given to each type of modeled device 1 for SVC, 2 for TCSC. The last string is the location of the devices. It denotes the numbers of the lines where the FACTS are to be placed.

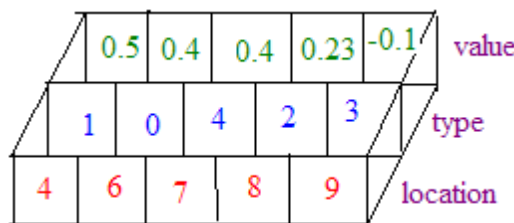

Fig.2. Configuration of FACTS devices

GA works on string structures (chromosomes), typically a list of binary digits representing a coding of the control parameters of a given problem. In each iteration of GA (referred as generation), a new set of string (i.e. chromosomes) with improved fitness is produced using genetic operators (i.e. selection, crossover and mutation). The GA searches for optimal solutions using the principles of evolution based on a certain string that is judged and propagated to form the next generation [17]. GA starts with random generation of initial population and then the selection crossover and mutation are performed until the best solution is obtained. GA is practical algorithm and very easy to implement in a power system analysis. Various steps to be performed in Genetic Algorithm implementation are as follows.

4.1 Selection

It is a simple procedure where n chromosomes are randomly selected from the parent population based on their fitness value, and the best of n is inserted in to population for further genetic processing. This process repeats until mating pool is filled [18].

4.2 Crossover

It is an important operator for the GA. The main objective of crossover is the structure recombination. The chromosomes of the two parents are selected and combined to form new chromosomes that inherit segments of information stored in parent chromosomes. It is a structured, yet randomized mechanism of exchanging formation between strings. It promotes the exploration of new regions in search space. Cross swapping operator is applied on the selected individuals [19].

4.3 Mutation

It is the operator used for the injection of new information. Mutation consists of protecting the process of reproduction and crossover effectively without much loss of the potentially useful genetic material. With the mutation random bits of the chromosomes changes from 0 to 1 and vice versa, and give new characteristics that do not exist in the parent population.

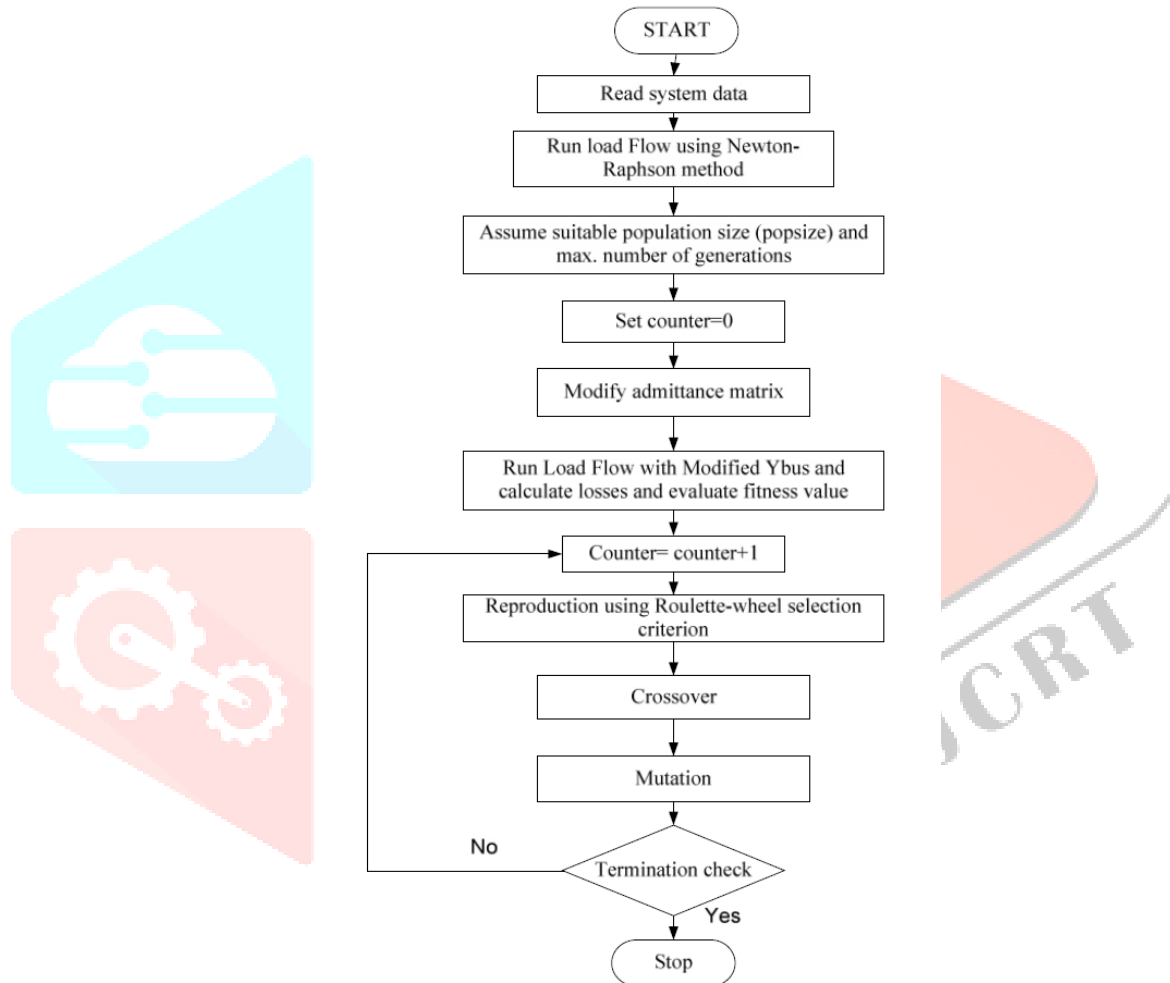

Fig.3. Flow chart for optimal location of TCSC

V. RESULTS AND DISCUSSION

In order to test the activeness of proposed technique IEEE 30 bus test system without shunt capacitors is used shown in Fig 4. The system has 6 generator buses (1 slack and 5 PV buses), 24 load buses and 41 transmission lines. Transmission lines 6-9, 6-10, 4-12 and 28-27 are with tap changer transformers and therefore are not suitable for positioning of TCSC. Only the remaining 37 lines are considered as candidate location for positioning of TCSC.

GA parameters for single objective optimization are

Population size -40,

Maximum no. of iterations=200

Elitism probability = 0.15

Crossover probability = 0.95
Mutation probability = 0.001

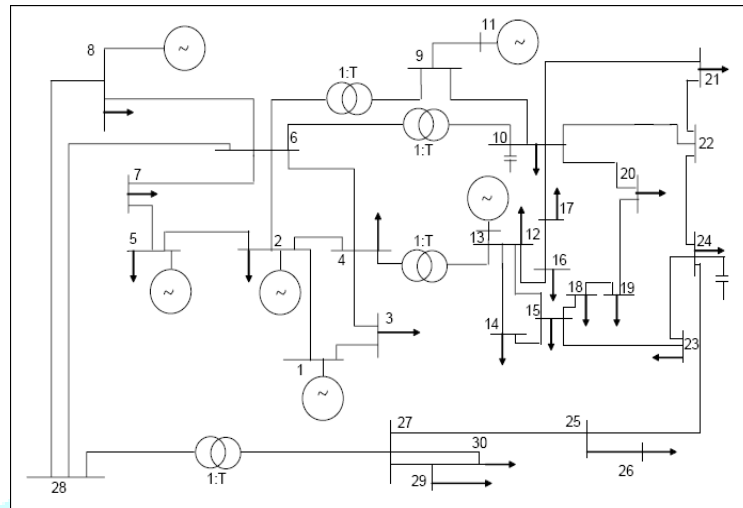

Fig.4. Single line diagram of IEEE 30 bus test system

For the placement of TCSC in 30-bus system using Genetic Algorithm, maximum number TCSC used are four and out of four, three are optimally placed by GA.

Table1. Location of TCSC decided by GA

LINE NO.	XTCS
2-5	-0.0536
9-11	-0.1429
15-18	-0.0298

Table2. Voltage and angle without TCSC and with TCSC at location specified by GA

Bus No.	Without TCSC		With TCSC	
	Voltage magnitude	Angle	Voltage magnitude	Angle
1	1.0600	0	1.06	0
2	1.0430	-5.3543	1.0430	-5.3543
3	1.0196	-7.5308	1.0234	-7.3744
4	1.0104	-9.2840	1.0105	-9.0849
5	1.0100	-14.1738	1.01	-12.6408
6	1.0096	-11.0581	1.016	-10.7637
7	1.0020	-12.8649	1.0057	-12.0631
8	1.0100	-11.8193	1.02	-11.5724
9	1.0392	-14.0644	1.0473	-13.7580
10	1.0215	-15.6706	1.0281	-15.3574
11	1.0820	-14.0644	1.0620	-13.7580
12	1.0496	-15.1245	1.0528	-14.8110
13	1.0710	-15.1245	1.0710	-14.8111
14	1.0320	-16.0018	1.0359	-15.631
15	1.0251	-16.0084	1.0295	-15.7027

16	1.0304	-15.6251	1.0352	-15.3118
17	1.0188	-15.8687	1.0249	-15.5538
18	1.0114	-16.6067	1.0173	-16.2205
19	1.0066	-16.7658	1.0127	-16.3978
20	1.0095	-16.5502	1.0158	-16.1955
21	1.0082	16.2178	1.0145	-15.9001
22	1.0120	-15.9811	1.0186	-15.6632
23	1.0085	-16.2294	1.0147	-15.9123
24	0.9991	-16.3007	1.0058	-15.9771
25	1.0032	-16.0720	1.0103	-15.7446
26	0.9852	-16.5038	0.9925	-16.1702
27	1.0145	-15.6559	1.0218	-15.3296
28	1.0078	-11.7163	1.0150	-11.4278
29	0.9944	-16.9077	1.0019	-16.5631
30	0.9828	-17.8067	0.9838	-17.4809

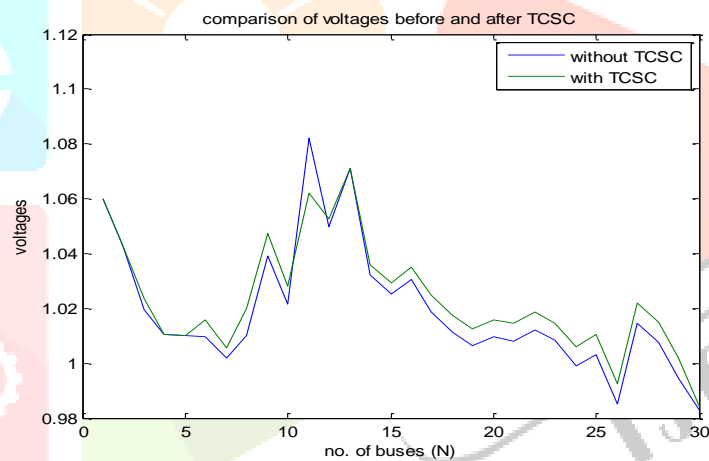

Fig.5. comparison of voltage level with and without TCSC at all buses

Figure 5 shows the comparison of voltage level with and without TCSC at location specified by GA. The voltage with TCSC is in the range of 0.98 to 1.07 p.u. means around $\pm 5\%$ which is in the tolerate able limit.

Table3. Result Analysis of 30-bus system with and without TCSC

Line number	X_{TCSC}	Active power without TCSC (pu)	Active power with TCSC (pu)
2-5	-0.0536	0.8241	0.9155
9-11	-0.1429	0	0.0000
15-18	-0.0298	0.0653	0.0667

Table 3, shows that the value of reactance of TCSC in all the three cases are capacitive so there is increase in active power flow. Values of the reactance of TCSC generated using Genetic Algorithm are in the working range are capacitive so there is increase in active power flow.

Table4. Real power losses with and without TCSC

Cases	Real Power Losses (p.u)
Without TCSC	0.1776
With TCSC	0.1483

Table 4, shows the real power losses with and without TCSC. With the placement of TCSC the real power losses are reduced. There is around 2.93% reduction of losses.

VI. CONCLUSION

Taking loss minimization as the objective function the type, location and rating are determined. TCSC device are placed at location determined by GA. The comparison of active power and voltage profile are done with and without TCSC. It has been seen that with the help of TCSC active power transfer capability of transmission line has been improved so that real power losses has been reduced and also the voltage profile has been improved.

REFERENCES

- [1] D.J.Gotham and G.T.Heydt, —Power flow control and power flow studies for system with FACTS devices,| IEEE Tran. Power system vol 13, no 1, Feb 1998.
- [2] M.Noroozian ,G.anderson, —Power Flow Control by use of controllable series component,|IEEE trans. Power Delivery, Vol 8, No 3, pp 1420-1429, July 1993.
- [3] F.D.GaGaliana, K.Almeida,—Assessment and control of the impact of FACTS devices on power system performance ,|IEEE Tran. Power System, vol 11, No 4, pp 1931-1936, Nov 1991.
- [4] N. G. Hingorani, “Power electronics in electrical utilities: role of power electronics in future power systems,” Proceedings of the IEEE Vol. 76 No.4, pp.481-482, Apr. 1988.
- [5] Sharma NK, Ghosh A, Varma RK (2003) A novel placement strategy for FACTS controllers. IEEE Trans Power Delivery 18: 982–987
- [6] Yorino N, EL-Araby EE, Sasaki H, Harada SH (2003) A new formulation for FACTS allocation for security enhancement against voltage collapse. IEEE Trans Power Syst 18:3–10
- [7] Chang CS, Huang JS (1998) Optimal multi-objective SVC planning for voltage stability enhancement. IEE Proc Generation Transm Distrib 145:203–209
- [8] Song SH (2004) Installation and operation of FACTS devices for enhancing steady-state security. Electr Power Syst Res 70:7–15
- [9] Lu Y, Abur A (2002) Static security enhancement via optimal utilization of thyristor controlled series capacitors. IEEE Trans Power Syst 17:324–329
- [10] Gerbex S, Cherkaoui R, Germond AJ (2001) Optimal location of multi-type FACTS devices in a power system by means of genetic algorithms. IEEE Trans Power Syst 16:537–544
- [11] Jurado F, Rodriguez JA (1999) Optimal location of SVC based on systems loadability and contingency analysis. In: 7th IEEE International Conference on Emerging Technologies and Factory Automation
- [12] Singh SN, David AK (2000) Congestion management by optimal FACTS device location. In: IEEE International Conference on Electric Utility Deregulation, Restructuring and Power Technologies
- [13] Ongsakul W, Bhasaputra P (2002) Optimal power flow with FACTS devices by hybrid TS/SA approach. Electr Power Energy Syst 24:851–857
- [14] Cai LJ, Erlich I, Stamtsis G (2004) Optimal choice and allocation of FACTS devices in deregulated electricity market using genetic algorithms. Power Syst Conf Expos IEEE-PES 1:201–207.
- [15] J. Baskaran, V. Palanisamy, “Genetic Algorithm Applied to Optimal Location of FACTS Device in a Power System Network considering economic saving cost”, Academic Open Internet Journal, 2005, Vol. 15, pp. 1-7.
- [16] Lai, L.L., MA, J.T., Yokohoma, R., Zhao, M., “Improved Genetic Algorithm for Optimal Power Flow Under Both Normal and Contingent Operation States”, Electrical Power Energy System, Vol.19, 1997, pp. 287-291.
- [17] Deb, K. Genetic algorithm in search and optimization: the technique and applications: Proceedings of Int. Workshop on Soft Computing and Intelligent Systems, 1998. 58-87.
- [18] Krishnasamy V., “Genetic Algorithm for Solving Optimal Power Flow Problem with UPFC”, International Journal of Software Engineering and Its Applications Vol. 5, No. 1, January, 2011.
- [19] Deb K., “Multi Objective Optimization Using Evolutionary Algorithm”, John Wiley & Sons, Ltd, pp.1-24, 2001.