



INTERNATIONAL JOURNAL OF CREATIVE RESEARCH THOUGHTS (IJCRT)

An International Open Access, Peer-reviewed, Refereed Journal

ADAPTIVE CONTROL OF TRAFFIC SIGNALS THROUGH AI TECHNIQUES

Mr.A Suresh¹ D Gangadhar² D Geethika³ G Geethika⁴ A Hepsibha⁵

¹Associate Professor, Department of CSE, Siddhartha Institute Of Engineering & Technology J.N.T.U Anantapur, Tirupathi,

Andhra Pradesh, India Email:

²³⁴⁵Department of CSE, Siddhartha Institute Of Engineering & Technology J.N.T.U Anantapur, Tirupathi, Andhra Pradesh, India,

Abstract:

This paper is proposed with a plan to identify the crisis vehicle particularly the rescue vehicle by utilizing the signal produced from the crisis vehicle to the traffic signal control unit. Ambulances are normally found out by the alarm sound, yet in some time where the drivers in the shut vehicle couldn't hear the sound appropriately and furthermore there exists confusion in the path in which the rescue vehicle is showing up. Some time, the alarm is switched off to decrease the strain on the patients. The proposed framework would give an answer for this issue. This framework utilizes a sensor that distinguishes the traffic density on the lane from the signal of the vehicle a ways off from the traffic signal to get out the traffic congestion on the lane and to give a quicker development of the crisis vehicle to serve the patients needing crisis. The lead of utilizing this framework is that signal have more high frequency and it is simple recognized from a good distance. We directed a study at various seasons of a day and furthermore at various climatic circumstances to study the detection of the signal from the ZigBee.

Keywords: IR detection, Raspberry Pi, ZigBee, Sensor.

I. INTRODUCTION

Clogged driving circumstances are a significant issue in making metropolitan networks. In truth it's reliably extending bit by bit nature makes it hard to find where the traffic thickness is all the more consistently, so that to design an unrivaled traffic light control and convincing traffic coordinating. In rush hour gridlock conditions, traffic sign acknowledgment (TSR) is utilized to oversee traffic signs and order or disallow specific activities. Advances like RFID and GSM are used in existing traffic signal frameworks to give savvy arrangements. Gridlocks

might emerge in view of enormous red light postpones which are hard corded and are autonomous of traffic.

Past works are finished to powerfully control versatile traffic signals. However, because of the restricted figuring power and reenactment instruments, early investigations center around settling the issue by profound support learning organization. In the traffic signal control issue, since no marks are accessible what's more, the traffic situation is impacted by a progression of activities, support learning is an effective method for tackling the issue also, has been applied in traffic signal control [1]. In these works, street traffic is displayed by restricted data, which can't be applied for an enormous scope. A helpful traffic signal control framework in light of support learning is proposed in [5]. The visual detecting innovation is applied to the clever traffic light system[6]. The creators utilize this innovation to ascertain the traffic volume of each and every path and line. A wise street traffic the board framework depends on the Human People group Hereditary Calculation proposed in [7]. Light devotion is proposed in [8] which is utilized to proliferate quicker through traffic-thick streets. Consequently diminishing the holding up season of crisis vehicles in rush hour gridlock thick paths. Versatile Steering for metropolitan Vehicular Organizations depends on the Back-Tension calculation proposed in [13].

II. EXISTING SYSTEM

The sensor is modified to recognize the blazing blue and red lights of the crisis vehicle as there might be an opportunity for the sensor to distinguish the shades of the vehicle or some other item.

While the glimmering blue and red lights of the reference point lights of the crisis vehicle is recognized by the sensor TC3200, the raspberry pi associated with the sensor gets animated and this in turn conveys a message to the ZigBee module of the transmitter.

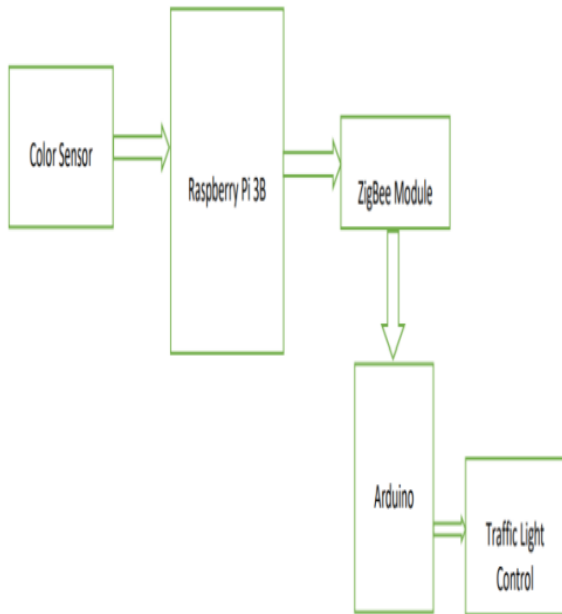

Fig.1: Block diagram of Existing model

On the recipient side the ZigBee module gets the sign from the transmitter side and conveys a message to the regulator here Arduino regulator is utilized. The regulator in turns controls the traffic light. Assuming the red light of the traffic framework is on it promptly changes to green light and in the event that the green light is on it expands the tie of the go-ahead for 30s.

Inconveniences:

- Increase complexity by combining controller along with processor
- Low exactness.
- The majority of the normal open access informational indexes have copied and excess occurrences, which will make prediction unrealistic

1. Client based issue

1.1 High Traffic Jam With augmenting number of transports on street, awkwardly robust traffic blockage has considerably augmented in significant urban communities. This happened customarily at the principal intersections usually toward the beginning of the day, up to office hour and in the evening, after available time. The fundamental impact of this matter is augmented time squandering of individuals out and about. The answer for this pickle is by fostering the program which different setting delays for various intersections.

1.2 No traffic, yet at the same time need to stand by At specific side, at times regardless of whether there is zero traffic, individuals need to pause. Since the traffic signal remaining parts red for the preset term, the street clients ought to hold on until the light go to green. The arrangement of this bind is by fostering a framework which recognizes traffic stream on every street and set timings of signs in like manner. Also, synchronization of traffic lights in adjoining intersections is which all compulsory.

III. PROPOSED SYSTEM

Basically, this gadget uses Raspberry pi , IR Sensor and ZIGBEE Module for additional correspondence. An IR sensor is an electronic gadget that used in order to measure the thickness (i.e.) traffic flow by producing waves, and converts into an electrical sign .IR sensors have two principal parts: the transmitter and recipient side.

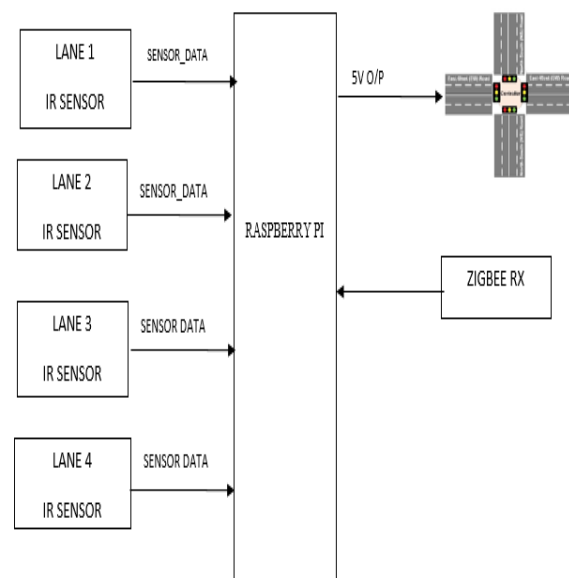

Fig 2: Proposed System Design for traffic density detection system

To measure the thickness(i.e.) traffic flow between the sensor and the vehicle, the sensor estimates the time it takes between the discharge of the wave by the transmitter to its contact with the collector, We find the IR sensor at the some degree of distance from the traffic signal, its action the vehicle thickness of one path and send the information to the raspberry pi gadget according to our guidance which one is the huge count of vehicle is to be open the green sign at the first, and the constant cycle are trailed by the above guidance. In case any rescue vehicle in the path ZigBee transmitter convey the information message to the recipient and the sign will be open consequently in that path.

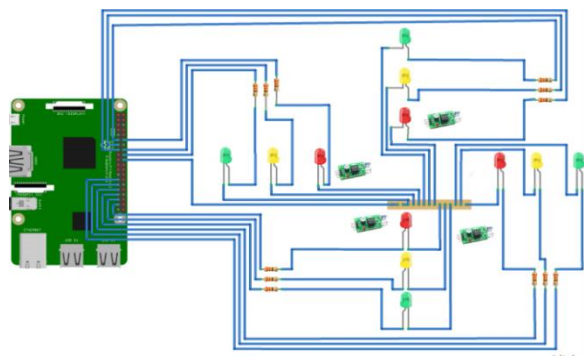

Fig 3: Pin Configuration diagram

The sensor is situated 6m over the ground and 150 meters away from the traffic light shaft as it would be more straightforward to clear the traffic at the hour of appearance of the emergency vehicle close to the traffic pole.

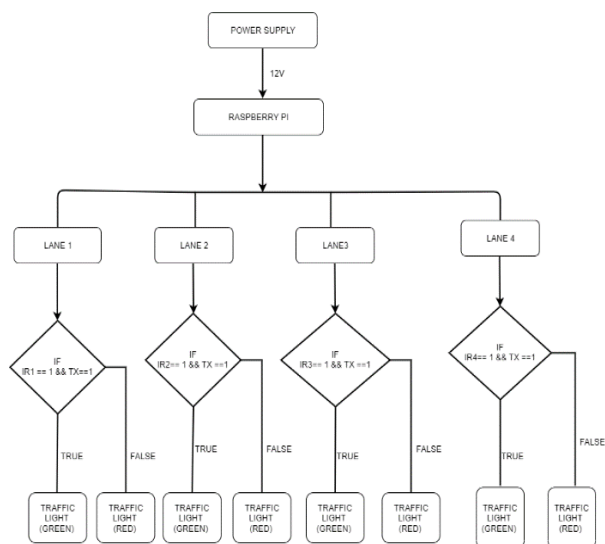

Fig 4: Data flow diagram

Design Methodology

IR Sensor

IR represents Infrared sensor. It is a detached gadget that measures infrared light from objects in its field of view. It is an electronic gadget that emanates to detect some parts of the environmental factors. An IR sensor can gauge heat of an item as well as distinguish the movement. The IR sensor comprises of IR transmitter and IR recipient.



Fig.5: IR Sensor

IR transmitter sends the infrared light and IR recipient sees the impression of that infrared light and measures the distance which is then shipped off the Arduino through simple information.

Resistor

A resistor is a uninvolved two-terminal electrical gadget that controls the progression of electric flow. It deals with the standard of ohm's regulation and the law expresses that the voltage across the terminals of resistor is straightforwardly corresponding to the ongoing coursing through it.

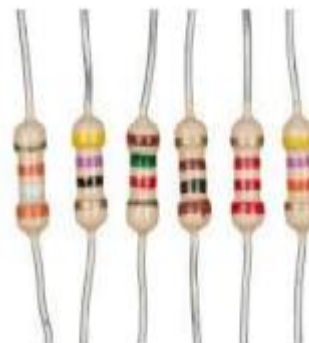

Fig.6: Resistors

RASPBERRY PI:

Raspberry Pi, commonly abbreviated as RPI is a low cost size of the size of a card that can be held on palm with the capacity of functioning as a full fledged computer. And with this small device, one can design and realize several applications and prototype models with the minimum knowledge of programming. It is the next gen computing device. Till date, a lot of RPI models are launched, all of which feature a Broadcom System on a Chip (SOC) BCM2837 with a CPU that Advanced RISC Machines (ARM) Cortex processor and on chip Graphics Processing Unit (GPU). RPI 3 has in-built Bluetooth and WiFi modules and Gigabit Ethernet for data transfer and connectivity. Via the USB ports, one can connect keyboard and mouse with the RPI. The RPI can be powered by a 5.1 micro USB port or through the USB ports, it has specified 3.3 V, 5 V and GND pins on GPIO.

TRAFFIC CONTROLLING

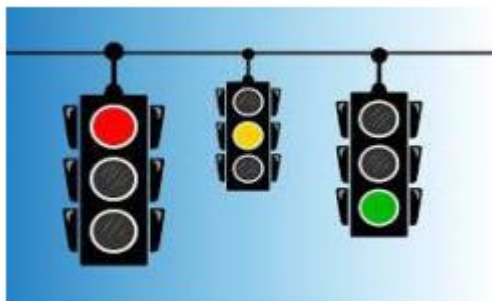

Fig.7: Traffic Controlling

The most common way of checking the traffic thickness of each side furthermore, changing the sign as per the thickness in each heading. At the point when the quantity of vehicles out and about is high then the traffic lights will be naturally different. The red sign will get changed to green sign when the traffic thickness out and about is high.

IV. OUTPUT IMAGES:

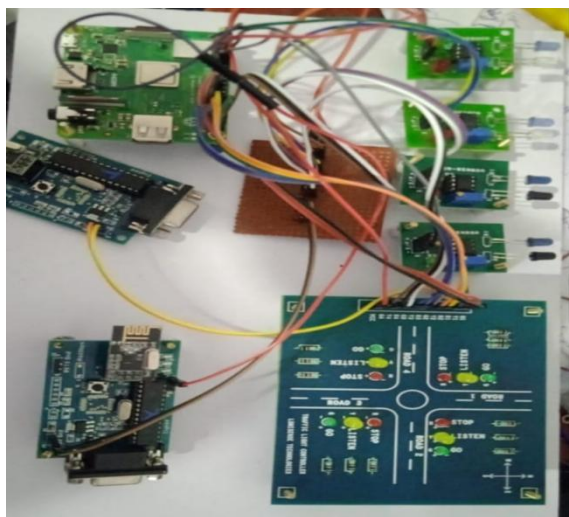

Fig.8: Proposed System Hardware

In this proposed hardware output mentioned above, Here we are using raspberry pi processor for control of the project, IR sensors are connected with raspberry pi for detecting the lane density. If lane 1 density is high then lane 1 will be green rest of the signals will be red signal same as that of other lanes. ZigBee Tx used to detect the ambulance presence in the lane so that we can change the signal according to the ambulance presence into the lanes.

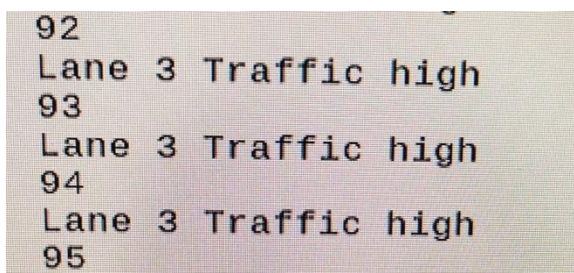

Fig.9: Detecting lane density

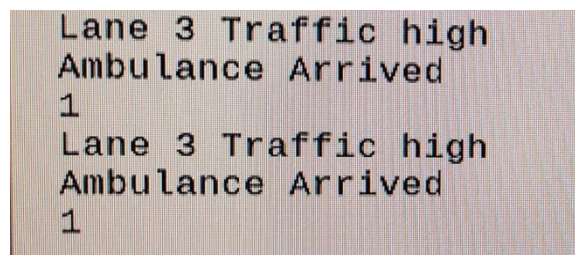

Fig.10: Detecting ambulance arrival

V. CONCLUSION

There is existent need of effective traffic the executives framework in our country, as India meets with 384 street mishaps consistently. To upgrade this blockage and negative time defer in rush hour gridlock a high level framework is planned here in this task. With field use of this innovation, the bothering tumult of traffic framework can be successfully channelized by conveying the schedule openings based on the densities of the vehicle load in specific paths of multi intersection crossing. We have effectively executed the model. The following stage forward is to execute this conspire in genuine situation for direct outcomes, previously executing it on the biggest scale. We trust that this may get a depleted change traffic the board framework.

References:

- [1]. Xiaoyuan Liang, Xunsheng Du and Guiling Wang "A Deep Reinforcement Learning Network for Traffic Light Cycle Control" IEEE Transactions on Vehicular Technology.
- [2] Liang Qi, MengChu Zhou, Fellow, IEEE, and WenJing Luan "Emergency Traffic-Light Control System Design for Intersections Subject to Accidents"
- [3] Yu Wang, Danwei Wang, Shangtai Jin, Nan Xiao, Yitong Li, and Emilio Frazzoli "Iterative Tuning With Reactive Compensation for Urban Traffic Signal Control"
- [4] Na Wu, Dewei Li, and Yugeng Xi, Senior Member, IEEE "Distributed Weighted Balanced Control of Traffic Signals for Urban Traffic Congestion"
- [5] Weirong Liu, Member, IEEE, Gaorong Qin, Yun He and Fei Jiang, "Distributed Cooperative Reinforcement Learning-Based Traffic Signal Control That Integrates V2X Networks' Dynamic Clustering"
- [6] Xiao Wen-juan, Liu Jian-feng, "Application of Vision Sensing Technology in Urban Intelligent Traffic Control System" 2018 4th International Conference on Computer and Technology Applications.

[7] Adnan A.Hnaif, Nagham AL-Madi, Mohammad Abduljawad, Amal Ahmad, “An Intelligent Road Traffic Management System Based on a Human Community Genetic Algorithm” 2019 IEEE Jordan International Conference on Electrical Engineering and Information Technology.

[8] Shanmughasundaram R, Prasanna Vadanam S,Vivek Dharmarajan, “Li-Fi Based Automatic Traffic Signal Control for Emergency Vehicles”, 2018 Second International Conference on Advances in Electronics, Computers and Communications (ICAEECC).

[9] Ali A. Zaidi, Balázs Kulcsár, and Henk Wymeersch, Member, IEEE “Back-Pressure Traffic Signal Control With Fixed and Adaptive Routing for Urban Vehicular Networks”

[10] Naga Harsha.J, Sheena Mariam Jacob, Nikhil Nair, J. John Paul, “Density Based Smart Traffic System with Real Time Data Analysis Using IoT

